



Transportation Security Administration

CHECKPOINT DESIGN GUIDE (CDG) ***Revision 4.0*** August 29, 2012

Prepared for the
Transportation Security Administration (TSA)
Office of Security Capabilities (OSC)

Prepared by:

LEO A DALY

8600 Indian Hills Drive • Omaha, NE 68114
402.391.8111

This page is intentionally left blank.

0.1 DISCLAIMER

The Transportation Security Administration (TSA) Checkpoint Design Guide (CDG) is prepared to help TSA Headquarters (TSA HQ), local TSA, airport stakeholders, and architectural and engineering (A&E) firms produce a consistent design product.

The CDG is intended to be used as a design guide. Not all answers to questions in the design process are addressed in this document and deviations are sometimes warranted. Seek guidance from the local Federal Security Director (FSD) and TSA HQ when the guidelines cannot be applied. As with any guide, previous experience, knowledge of local and national codes, and professional judgment are to be integrated with the direction provided herein to develop the optimum design.

This document is intended to be printed double-sided. Select flip short edge when printing.

All graphics/drawings contained in this document are not meant to be scaled.

This page is intentionally left blank.

1.0 INTRODUCTION TO SECURITY SCREENING CHECKPOINTS (SSCPS) 1

1.1 GENERAL INFORMATION 3

1.2 STAKEHOLDER COORDINATION 4

1.3 PLANNING CONSIDERATIONS 4

1.4 AIRPORT OPERATIONAL TYPES 7

1.5 CHECKPOINT IMPROVEMENTS 8

1.6 DESIGNING FOR THE PROCESSES & EQUIPMENT 11

2.0 SSCP ELEMENTS.....13

2.1 PRE-SCREENING PREPARATION INSTRUCTION ZONE 15

2.1.1 TSA Mandatory Signs 15

2.1.2 TSA Instructional Signs..... 15

2.1.3 TSA Directional Signs 15

2.1.4 TSA Local Signs 15

2.2 QUEUE..... 16

2.2.1 Automated Wait Time (AWT) 17

2.2.2 Travel Document Checker (TDC) & Credential Authentication Technology/Boarding Pass Scanning System (CAT/BPSS) 18

2.3 BIN CART 21

2.4 DIVEST TABLE 22

2.5 CARRY-ON BAG SCREENING..... 23

2.5.1 Advanced Technology (AT) X-Ray 24

2.5.2 Manual Diverter Roller (MDR) 33

2.5.3 Composure/Extension Rollers 34

2.6 WALK THROUGH METAL DETECTOR (WTMD) 37

2.7 ADVANCED IMAGING TECHNOLOGY (AIT) 39

2.7.1 AIT ETD..... 40

2.7.2 Slope Tolerance..... 40

2.8 BARRIERS43

2.9 ADA/ACCESS GATE.....44

2.10 PASSENGER CONTAINMENT, INSPECTION & RESOLUTION45

2.10.1 Passenger Containment (Half J3)46

2.10.2 Private Screening Room (PSR)47

2.11 SECONDARY SCREENING49

2.11.1 Explosive Trace Detection (ETD)49

2.11.2 Bottle Liquid Scanner (BLS).....49

2.11.3 Mobile Cabinets51

2.11.4 Bag Search Table.....52

2.11.5 Passenger Search Position.....52

2.12 COMPOSURE BENCH53

2.13 SUPERVISORY TRANSPORTATION SECURITY OFFICER (STSO) PODIUM53

2.14 SSCP BOUNDARIES.....55

2.15 EXIT LANE.....55

3.0 STANDARD SSCP LAYOUTS57

3.1 TSAPRE✓™58

3.2 STANDARD SSCP ARRANGEMENT63

4.0 SSCP ELECTRICAL REQUIREMENTS.....67

4.1 DATA REQUIREMENTS.....67

4.2 POWER REQUIREMENTS.....74

4.3 POWER/DATA RECEPTACLES.....76

4.4 POWER/DATA CONFIGURATIONS.....81

4.5 POWER/DATA PLANS.....87

4.6 CCTV REQUIREMENTS.....89

4.7 LIGHTING REQUIREMENTS91

5.0 SAFETY.....93

6.0 APPENDIX A - SSCP TERMINOLOGY95

7. APPENDIX B - CHECKLIST99

7.1 QC PLAN CHECKLIST100

8. APPENDIX C - STANDARD EQUIPMENT DIMENSIONAL CRITERIA..... 103

8.1 RAPISCAN AT X-RAY LAYOUTS.....104

8.2 SMITHS AT X-RAY LAYOUTS112

8.3 L3 AT X-RAY LAYOUTS120

9. APPENDIX D - LEGACY ITEMS 125

9.1 QUEUE (REFER TO SECTION 2.2).....126

9.1.1 Diamond Self Select (DSS).....126

9.2 CARRY-ON BAG SCREENING (SEE SECTION 2.5)128

9.2.1 Threat Image Projection (TIP) Ready X-Ray (TRX)128

9.3 ADVANCED IMAGING TECHNOLOGY (SEE SECTION 2.7).....131

9.3.1 Image Resolution131

9.4 PASSENGER CONTAINMENT, INSPECTION & RESOLUTION (SEE SECTION 2.10).....132

9.4.1 Passenger Containment (J3)132

9.4.2 Passenger Inspection (N3).....133

9.4.3 Cast & Prosthesis Imager134

9.4.4 Remote Resolution Room (I/O Room) with AIT Operator Workstation135

9.5 POWER/DATA PLANS (SEE SECTION 4.5)137

9.6 AUTOMATIC EXPLOSIVE DETECTION SYSTEM (AUTOEDS).....141

9.7 AutoEDS ARRANGEMENTS144

<i>Date</i>	<i>Revision No.</i>	<i>Description</i>	<i>Section(s) Affected</i>
12/17/08	0	Original publication	All Sections: 1, 2, 3, 4, 5, & 6
02/11/09	1	Incorporated OIB feedback from the original publication.	All Sections: 1, 2, 3, 4, 5, & 6
02/19/10	2	Incorporated power/data requirements for all SSCP equipment.	Section 4 Only
03/10/11	3	Updated the SSCP equipment, the arrangements, and the electrical requirements.	All Sections: 1, 2, 3, 4, 5, & 6
08/29/12	4	Updated the SSCP equipment, the arrangements, and the electrical requirements.	All Sections: 1, 2, 3, 4, 5, & 6

1.0 INTRODUCTION TO SECURITY SCREENING CHECKPOINTS (SSCPS)

The Transportation Security Administration (TSA) is mandated by law to screen air travelers and their carry-on bags in order to intercept prohibited items at the Security Screening Checkpoints (SSCP) at approximately 450 airports across the United States. Since each checkpoint represents a point of entry into the aviation system, each must meet security criteria. SSCPs were less complex pre-9/11. SSCPs have evolved considerably since the formation of TSA in 2002, and continue to evolve with improved technology and increased experience. Because the threat environment is constantly changing, this Checkpoint Design Guide (CDG) was created to communicate the most current accepted guidelines for checkpoint design.

The intent of this document is to provide a description of the SSCP equipment that is used today. Also included is information that can be used to locate equipment within the checkpoint to provide the highest level of security screening and efficiency beginning at the queue and continuing through the composition area. The information in this guide should be used when designing new checkpoints or reconfiguring existing checkpoints. All designs and reconfigurations must be coordinated with TSA HQ, local FSD and staff, and local airport stakeholders so that the recommended guidelines can be site-adapted for each checkpoint. This document is a “living” document that is updated when new technologies or processes are adopted by TSA HQ.

There are multiple layers of security in place at airports today to facilitate the safe movement of people and commerce throughout the airport transportation system. These layers are roadblocks to potential terrorist paths because they are equipped to detect and minimize threats that could occur. Refer to **Figure 1-1**.

Every airport and airport terminal building is unique in physical design and operational requirements. A single SSCP solution will not work for every checkpoint, nor will it work for every checkpoint at the same airport. Every SSCP location must be reviewed as an entity of the overall airport security system. The CDG provides direction and recommendations on how to locate and size a new SSCP based on the following conditions.

- Facility Infrastructure & Operations
- Current Screening Technology/Equipment
- Type of Risk that is Present or Anticipated
- Passenger Loads/Number of Enplanements

Improper SSCP design results in terminal and checkpoint queue congestion, long passenger wait times, flight delays, missed flights, and unnecessary security risks. Proper SSCP design helps avoid costly problems for the airport, airlines, and TSA. It also provides a smoother and safer experience for the passenger.

This document is divided into the following sections.

- Section 1.0: Introduction to Security Screening Checkpoints (SSCPS)
- Section 2.0: SSCP Elements
- Section 3.0: Standard SSCP Layouts
- Section 4.0: SSCP Electrical Requirements
- Section 5.0: Safety
- Section 6.0: Appendix A - SSCP Terminology
- Section 7.0: Appendix B - Checklist
- Section 8.0: Appendix C - Standard Equipment Dimensional Criteria
- Section 9.0: Appendix D - Legacy Items

Figure 1-1 Twenty Layers of Security

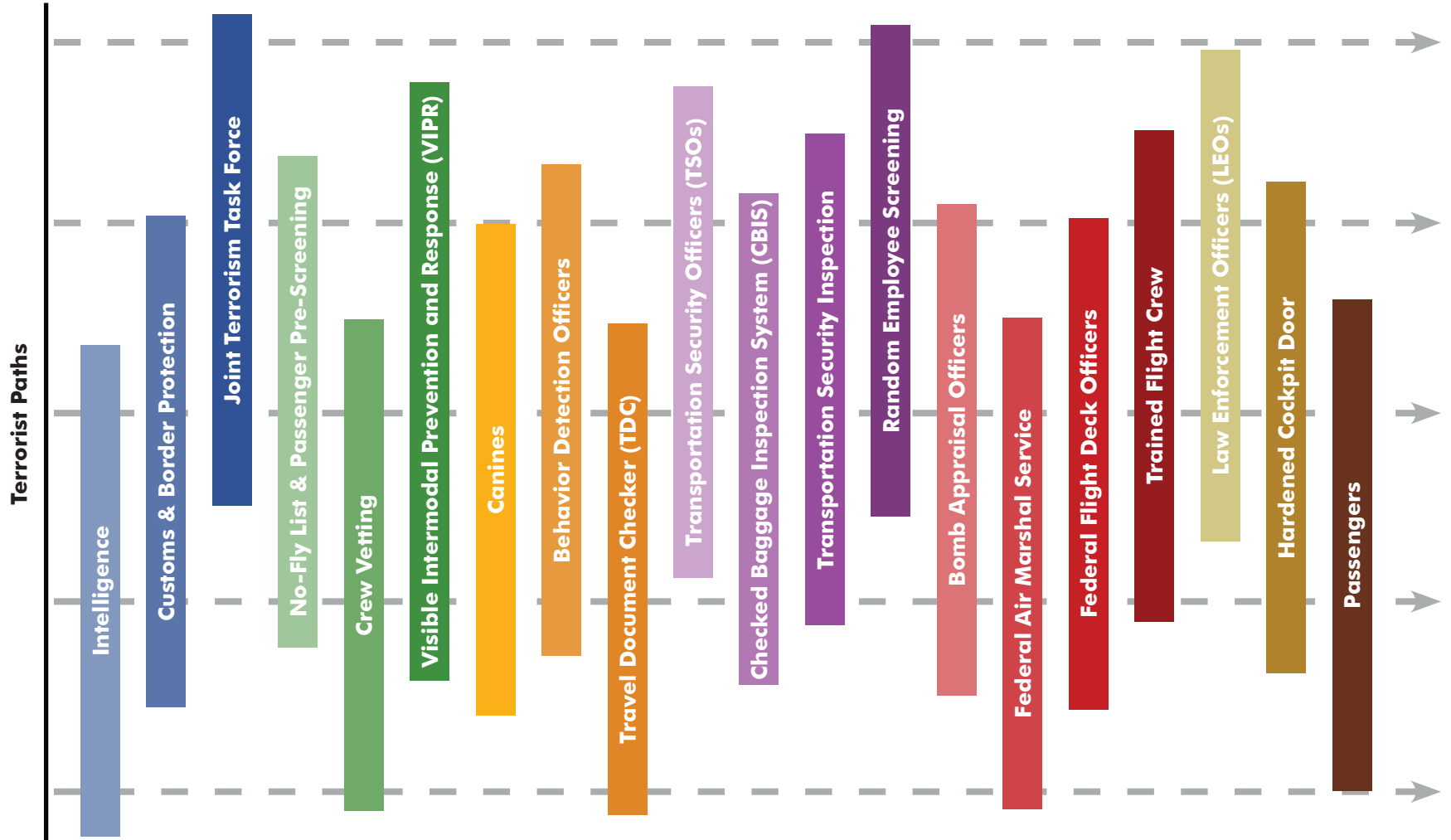

1.1 GENERAL INFORMATION

SSCPs are a critical element to an airport's overall terminal design and must be considered in the early stages of planning and conceptual layout. Performance requirements of an SSCP and airport/airline responsibilities are not included in the CDG. This information can be obtained from TSA regulatory documents.

Security screening is intended to deter and prevent hijackings and the transport of explosives, incendiary or dangerous weapons aboard commercial aircraft. Sterile areas are defined as those areas where aircraft access is possible and persons have undergone security screening to access the areas. Non-sterile areas are accessible to the general public.

When designing a new terminal or checkpoint, or reconfiguring an existing terminal or checkpoint, the following should be considered during design.

- Sufficient square footage to support current TSA technology and screening processes
- Ability to secure exit lanes during operational and non-operational hours of the SSCP

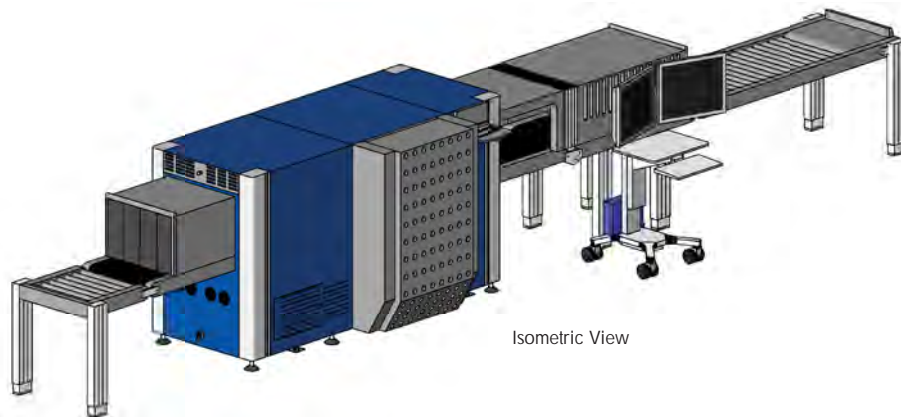

- Wheelchair accessibility and allowances for persons with disabilities and/or assistive devices
- Minimal interruption or delay to the flow of passengers and others being screened
- Effective and secure handling of goods that are transported from the non-sterile area to the sterile area
- Protection of SSCP equipment during non-operational hours
- Equipment maintenance clearances
- Operational flexibility in response to changes in passenger loads, equipment, technology, processes, and security levels
- Efficient and effective use of terminal space
- Acceptable and comfortable environmental factors, such as air temperature, humidity, air quality, lighting, and noise
- Safe and ergonomic design
- Coordination of power, data, fiber optics, CCTV, and lighting at the SSCP
- Contingency plans for power outages and system challenges (good practice for the airport, but not required by TSA for the checkpoint)
- Allowance for TSA office space which needs to be negotiated through the Office of Real Estate
- Staffing efficiency for TSA and other security personnel

1.2 STAKEHOLDER COORDINATION

Key individuals with TSA HQ, local FSD and staff, government agencies, and airport/airline operations should be involved during the SSCP design process. These groups will be able to facilitate dialogue regarding local building codes, mutual aid agreements with local law enforcement/emergency responders, and joint commercial/military entities.

Permitting and approvals can be a factor in design and final deliverables. Depending on site location and project complexity, building permits may or may not be required. This should be determined early on in the project. Some sites require airport authority approval only. Permitting or approvals may require additional information in the deliverable that is beyond the information given in this guideline. Early determination of approval requirements will avoid inconvenient changes later in the process.

1.3 PLANNING CONSIDERATIONS

SSCPs are created by combining standard 1- and 2-lane module sets. A typical 1-lane module set consists of an X-ray, Manual Diverter Roller (MDR), Walk Through Metal Detector (WTMD) and/or Advanced Imaging Technology (AIT), Alternate Viewing Station (AVS), Explosive Trace Detection (ETD), Bottle Liquid Scanner (BLS), Passenger Inspection, and Bag Inspection. A 2-lane module set is the same as a 1-lane module set with the addition of another X-ray. **Figure 1-2** illustrates a 5-lane layout which is a combination of two 2-lane module sets and one 1-lane module set. These module sets are discussed in more detail in Section 3.0. The module sets are created based on the recommended TSA spacing for passenger ingress/egress, clearance for maintenance activities, and prevention of passenger breaches. The separation of sterile and non-sterile areas provide a controlled and contained screening environment.

A modular design enables TSA to determine the depth and width needed for a set number of lanes. The number of lanes is based on

the passenger load and the physical space provided by the airport. Contact the TSA Office of Security Capabilities (OSC) to assist with determining the number of lanes needed to meet the passenger load in the space allotted for the SSCP. As the number of enplanements per year increases and the equipment and technology evolve, the SSCP needs to have the flexibility to change and expand. Allowances for modifications must be included in the Airport Master Plan.

Vulnerabilities specific to a particular airport will dictate where the checkpoint is situated within the terminal. Some airports may locate the SSCP at or near the entrance of the terminal, making all spaces beyond the SSCP sterile. Thoughtful consideration must be given to passenger queuing if the SSCP is placed near the terminal entrance. Massing people in public areas should be avoided. The more common choice is to position the SSCP deep in the terminal. During periods of elevated threat or special events, temporary SSCPs may need to be installed. If this is a potential option, floor space and temporary utilities should be planned into the terminal design by the airport.

Airports with international flights have a Federal Inspection Service (FIS) checkpoint. This is a checkpoint dedicated specifically for arriving international passengers. Arriving international passengers are required to undergo U.S. screening before transferring to a domestic flight because the U.S. screening process has different requirements and provisions than screening processes at non-U.S. origins. The screening requirements for a FIS checkpoint are the same as other checkpoints, but the volume varies based on the frequency of inbound international flights.

Care should be taken to preserve the paths and clearances required by the local and national building codes to provide for barrier-free movement in the checkpoint and life safety requirements for exiting. Observing exiting for airport and TSA staff as well as passengers is gaining closer scrutiny from the reviewing agencies. Some locations may require emergency exiting through a checkpoint. Many sites require exit studies showing how the checkpoint affects the

emergency exiting of the terminal as a whole. This could require modifications or additions to the checkpoint beyond guidelines set herein.

Airport security technology is a dynamic and rapidly changing field. No matter how carefully an airport is designed to take maximum advantage of the current technology, designs must be sufficiently adaptable to meet the changing threats and support future technology. Security screening equipment dimensions and/or processes may change, requiring the entire airport security managerial infrastructure to make important decisions regarding modifications, which the designer must then accommodate. The designer's task will be easier if the original design has anticipated the need for change and has provisions for expansion. Electrical and data infrastructure should also be flexible. Planning for surface or in-floor raceways will best support future changes.

Figure 1-2 Example SSCP

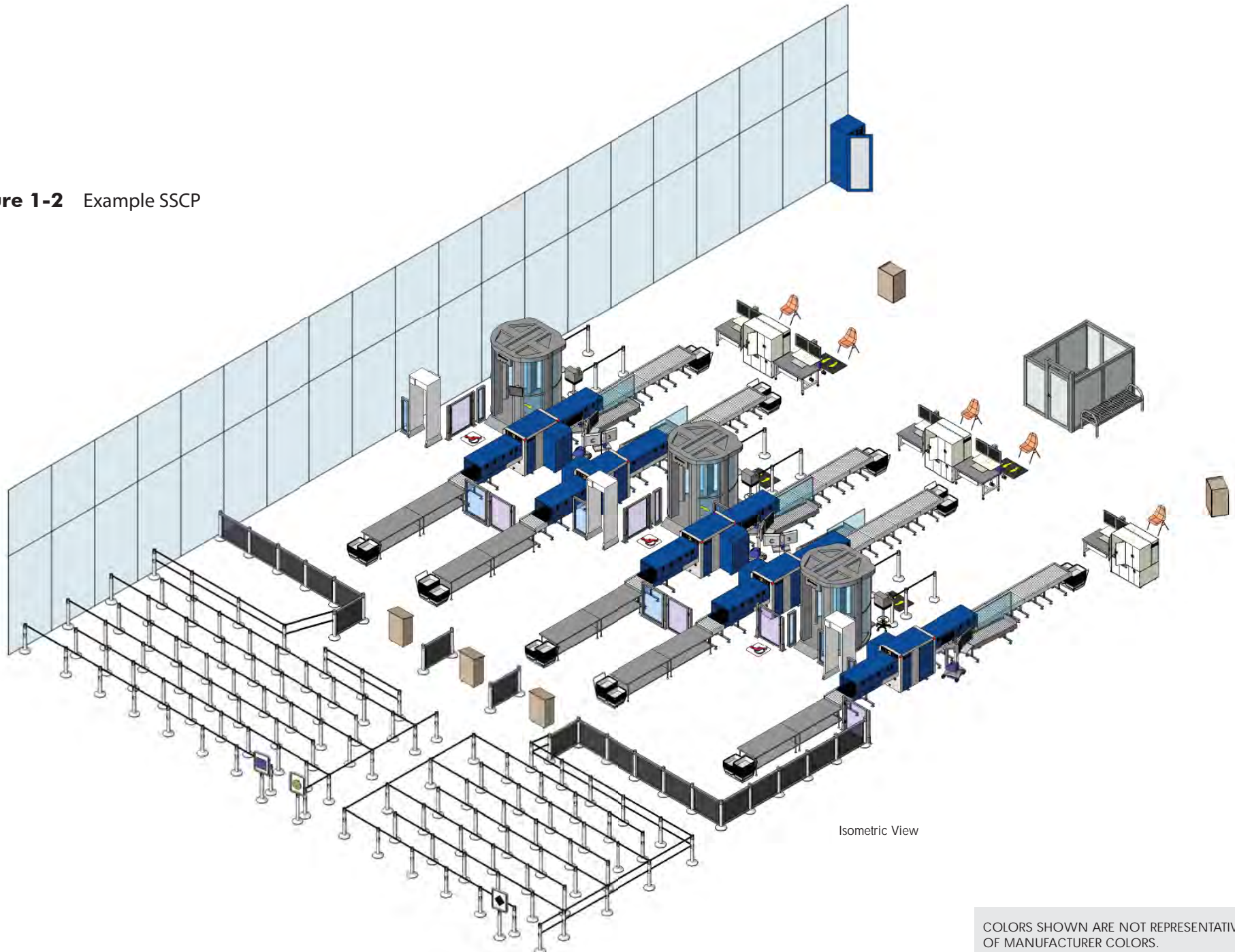

COLORS SHOWN ARE NOT REPRESENTATIVE OF MANUFACTURER COLORS.

1.4 AIRPORT OPERATIONAL TYPES

Airports are typically categorized by the number of enplanements per year. This defines the airport's category. Airports can be a hub, spoke of a hub, or stand-alone. Refer to **Figure 1-3** for a sample of a region of the TSA Federalized Airports. Airports are also characterized as Transfer/Hub, Origin and Destination (O&D), or a combination of the two, with regional and commuter traffic included in all three.

In Transfer/Hub airports, transfer passengers frequently move from gate to gate without passing through an airport SSCP. If concessions are located in the non-sterile area, there is incentive for passengers to exit the sterile area and subsequently re-enter the sterile area through the SSCP, thus increasing the passenger load that might otherwise be unnecessary. In this arrangement, concessions should be located in the sterile area to allow passengers to move among gates along multiple concourses without needing to be re-screened.

O&D airports are best served by locating the SSCP near the individual hold rooms or passenger waiting area so that the SSCP can be staffed for particular departures. While this makes staffing more dynamic, it requires more real estate and equipment.

Small airports operate a bit differently than their larger O&D and Transfer/Hub counterparts. Typically, there is little or no hold room space, and passenger screening doesn't occur until just before the flight boards. Often the SSCPs at small airports are located at the gate. In some cases, space may be so limited that it is best to co-locate the checked bag screening adjacent to or in combination with

passenger screening. This configuration has specific equipment called AutoEDS that is capable of screening carry-on and checked baggage. This layout is efficient and economical in that one piece of equipment and the same staff can provide two types of screening.

Figure 1-3 TSA Federalized Airports



1.5 CHECKPOINT IMPROVEMENTS

New construction and checkpoint reconfigurations to the SSCP must be closely coordinated with TSA HQ so that the proper equipment and resources are deployed to support the changes that heightens security, increases throughput, reduces on-the-job injuries, makes staffing more dynamic, improves passenger customer service, and is consistent with this design guide. Coordinate with TSA to obtain the most recent CAD blocks and mod layouts.

Funding for SSCP modifications or reconfigurations will depend on the scope of work. TSA HQ may approve the work, but may not provide all of the funding for it. For example, in the case of an equipment request, TSA HQ may supply the equipment, but request the airport stakeholders to provide new power/data receptacles to support the equipment. Shared cost solutions are common for these types of requests and have a significant schedule benefit. TSA HQ, local TSA, airport stakeholders, and the SSCP designer should determine funding responsibilities in the early planning stages of the project before design begins.

An outline of the checkpoint modification process is shown in **Figure 1-4** starting with project inception all the way to project approval. Local TSA and airport stakeholders should follow this process when modifications to an existing SSCP are needed. **Figure 1-5** illustrates the OSC design review sub-process. This critical sub-process ensures designs meet the requirements of the CDG, allows for concurrence by TSA HQ with deviations from the CDG, and allows opportunities to understand the impact in building infrastructure. Once the project is approved, the appropriate department within TSA HQ helps local TSA and the airport stakeholders execute the project. Tasks vary from shipping equipment to putting the project out for bid.

Equipment is provided by TSA based on passenger volume, aircraft type, and passenger load factor. When equipment is needed for a

checkpoint reconfiguration, local TSA should request equipment from TSA HQ via the Equipment Request Interface (ERI) at the following URL.

<https://team.ishare.tsa.dhs.gov/sites/OST/ERI/default.aspx>

Access to this link can be gained by requesting a user account and password. The Requirements Management Advisory Group (ReMAG) assigns an ID Number to each equipment request and tracks the request from the request date all the way to the received and/or installation date. ReMAG also evaluates each request carefully to determine the validity of the request.

TSA HQ stores Technical Security Equipment (TSE) and ancillary equipment at the TSA Logistics Center (TLC) in Grapevine, Texas. Commonly used equipment or equipment that wears out quickly is typically kept in stock. Other equipment, such as new technology, is typically stocked and deployed for a specific deployment task order. Local TSA is responsible for submitting the equipment request via the ERI. Equipment that is available for the checkpoint can be found in the Office of Security Capabilities (OSC) Passenger Screening Program (PSP) Ancillary Equipment Guide. This document can be provided by local TSA from the ERI Interface. Verify the most current version as this document is updated often. This document includes the following:

- Available Equipment
- Equipment Ordering Information
- Equipment Description
- Technical Product Data

Figure 1-4 Checkpoint Modification Process

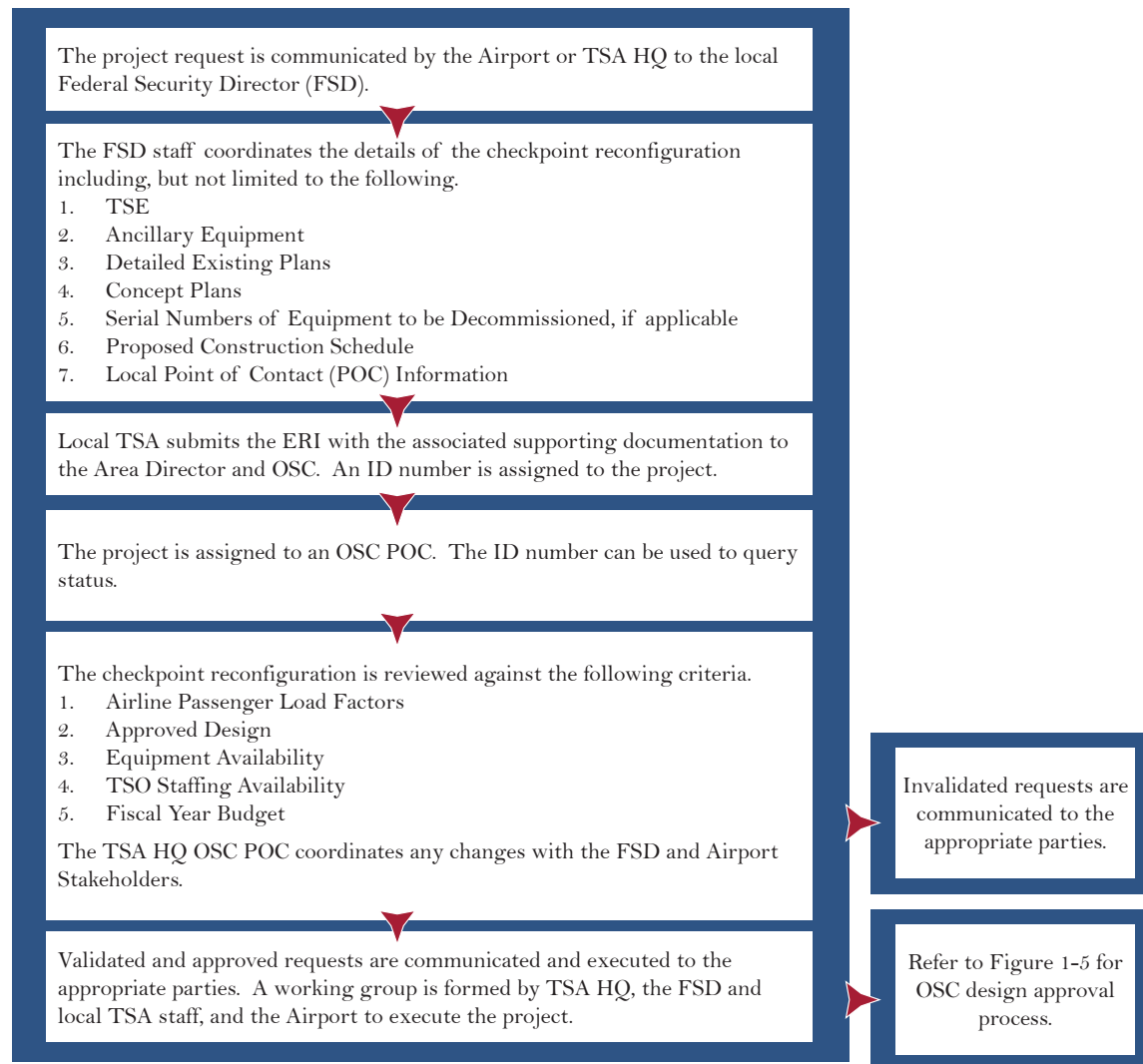
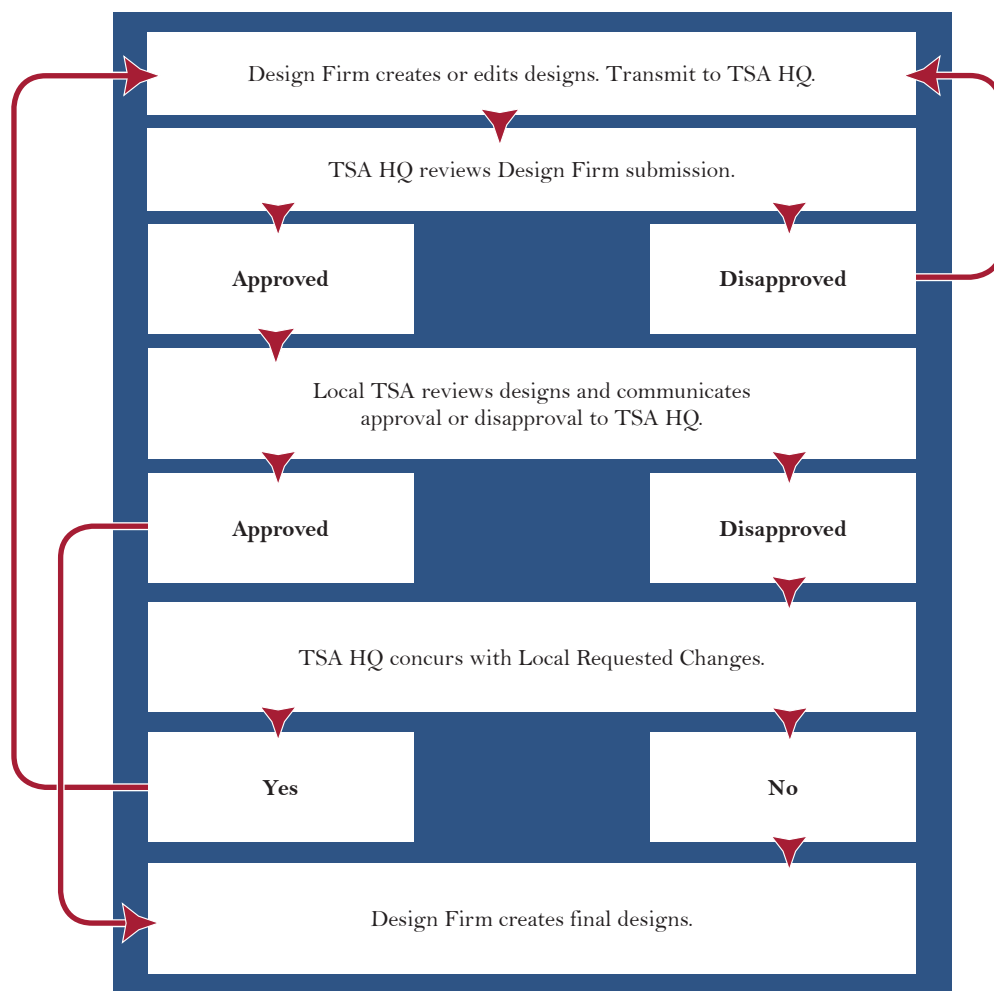

Figure 1-5 OSC Design Approval Sub-Process



1.6 DESIGNING FOR THE PROCESSES & EQUIPMENT

TSA equipment placement is intended to increase the level of security and improve the flow of passengers through the checkpoint. This is accomplished by providing adequate space for passengers to divest and compose which minimizes the occurrence of bottlenecks at the checkpoint. Checkpoint configurations should also create a reasonable work environment for Transportation Security Officers (TSOs) to perform multiple functions within close proximity to each other. Airport and Airline architecture firms will receive guidance from TSA HQ on where to locate screening equipment in such a way that will increase the baseline performance of the equipment, improve the passenger experience, and decrease the time required for screening. A TSA HQ design representative must approve any final airport/airline design for new or reconfigured checkpoints. Refer to **Figure 1-5** for more information.

Good design should conform to the activity that it supports. Procedures are in place to continuously review and refine the process that every passenger and bag must undergo in order to properly fulfill TSA's goals for the SSCP. It is critical that the design layout support this process.

This page is intentionally left blank.

2.0 SSCP ELEMENTS

The intent of this section is to introduce all of the elements of a standard TSA SSCP. These elements consist of Technical Security Equipment (TSE) and non-powered ancillary equipment. The equipment in this section is listed in the order that a passenger encounters it, from the non-sterile area to the sterile area. It includes most but not all of the A&E technical data that a designer would need to configure a checkpoint. This guide is intended to be general and is not a replacement for manufacturer information or recommendations for clearances, power, etc. All SSCP equipment, including private screening rooms, must meet all local code requirements and standards for HVAC.

Essentially every checkpoint has the same elements which are site adapted to the existing conditions. While the queue and composure areas can vary significantly from checkpoint to checkpoint, the screening lanes are fairly consistent with the type of equipment deployed even though the equipment footprint can vary by manufacturer. Manufacturers for a particular type of equipment are chosen by TSA HQ based on the following criteria.

- Manufacturers Deployed at the Hub Airport
- Width & Depth of Checkpoint
- Lane-to-Lane Spacing
- Structural Capacity of the Floor
- Column Sizes, Quantities, & Locations
- Existing Maintenance Contracts
- Staff Familiarity with a Manufacturer
- Airline Passenger Load Factors
- Passengers per Hour
- Ceiling Height
- Floor Slope

A layout of most but not all of the SSCP elements is represented in **Figure 2-1**. Passenger flow goes from left (non-sterile) to right (sterile). All equipment included in this section can be ordered from TSA HQ by following the process outlined in Section 1.5.

Figure 2-1 SSCP Elements

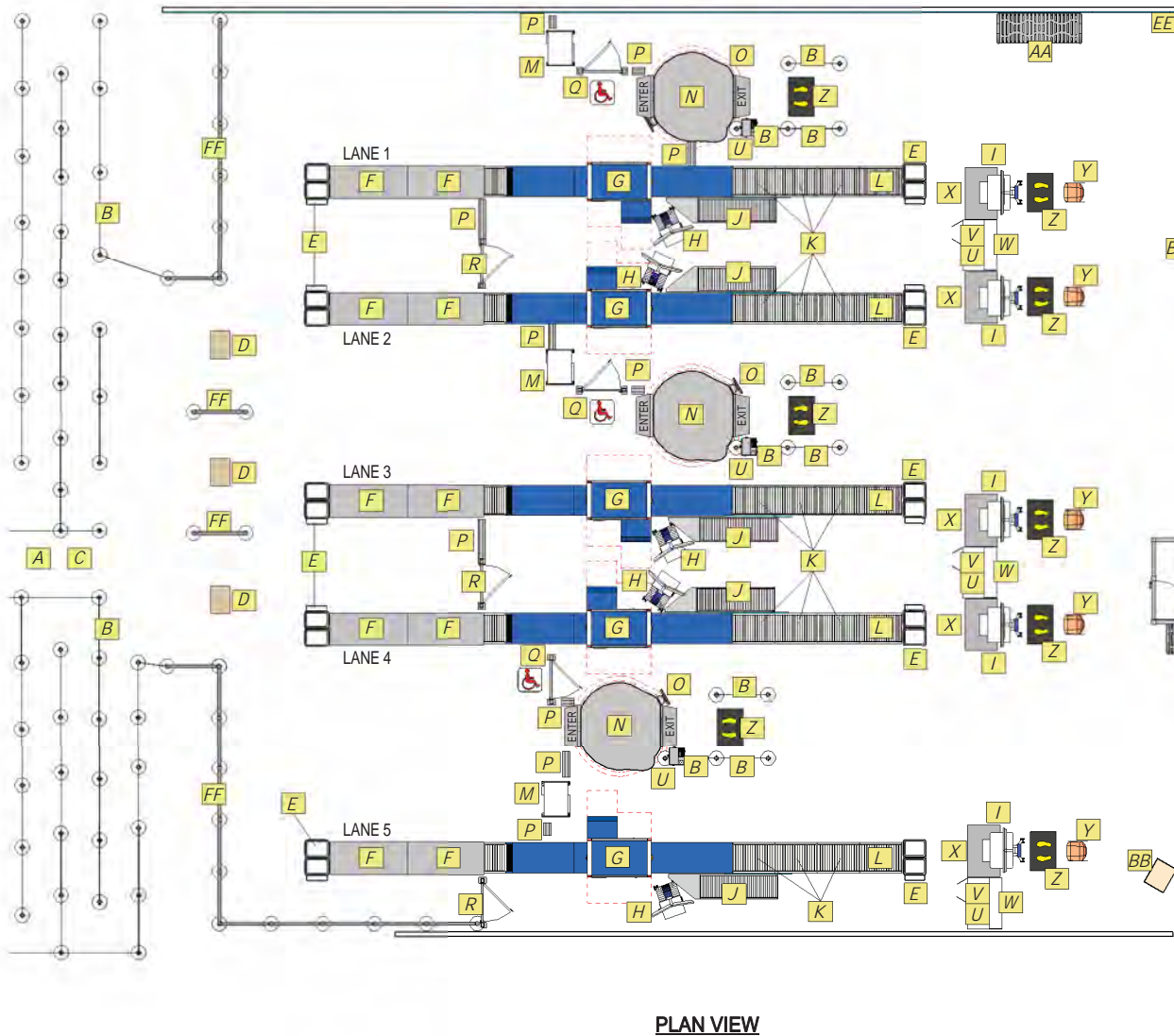

LEGEND

--- Service Area

A Pre-Screening Preparation Instruction Zone	S Private Screening Room (S3 [shown] or S3-A Kit)
B Queuing Stanchions	T Cast & Prosthesis Imager (CPI) [not shown]
C Automated Wait Time (AWT)	U Explosive Trace Detection (ETD)
D Travel Document Checker (TDC) & Credential Authentication Technology/Boarding Pass Scanning System (CAT/BPSS)	V Bottle Liquid Scanner (BLS) ETD-BLS Mobile Cabinet
E Bin Cart	W (ETD mobile cabinet not shown)
F Divest Table	X Bag Search Table
G Advanced Technology (AT2) X-ray (TRX, AT1, and AutoEDS not shown)	Y Passenger Inspection Chair
H Operator Cart	Z Passenger Inspection Mat
I Alternate Viewing Station (AVS) for AT2 only	AA Composure Bench
J Manual Diverter (MDR)	BB Supervisor Transportation Security Officer (STSO) Podium
K Composure/Extension Roller	CC Exit Lane (not shown)
L Composure/Exit Roller	DD IT Cabinet
M Walk Through Metal Detector (WTMD)	EE Kronos Time Clock
N Advanced Imaging Technology (AIT)	FF Barrier Stanchions
O Touch Control Operator Panel (TCOP)	
P Barriers (1', 2', 3', & 4')	
Q American Disabilities Act (ADA) Gate	
R Access Gate	

2.1 PRE-SCREENING PREPARATION INSTRUCTION ZONE

The Pre-Screening Preparation Instruction Zone begins as early as the curbside ticket counters and typically ends at the Travel Document Checker (TDC) deep in the queue. This zone should incorporate architectural features of the airport and be designed to provide a calm environment for the passenger. Signage, instructional videos, and “ambassador” staff or volunteers, when available, should be used to reduce passenger stress and ease movement through the SSCP.

Simple and effective checkpoint signage that has been created and approved in the TSA HQ Office of Public Affairs can be used to direct and instruct passengers on screening requirements and procedures. TSA signs are either 11” by 14” or 22” by 28” frames that can be mounted on top of a floor stanchion. Refer to **Figure 2-2**. The signs are divided into four categories: TSA Mandatory Signs, TSA Instructional Signs, TSA Directional Signs, and TSA Local Signs. Refer to the most current version of the TSA Airport Signage Guidelines, available on the TSA Intranet, for specific sign descriptions and where to locate these signs within the checkpoint. Signage is not typically part of a checkpoint design but space should be allocated for signage when designing a new checkpoint.

2.1.1 TSA Mandatory Signs

TSA Mandatory Signs display critical information and TSA policies to the passenger such as listing prohibited items or the liquids, aerosols, and gels (LAGs) policy. These signs need to be visible from both sides, prominent, easy to read, and located along the path of departing passengers without obstructing queue lanes or being a safety hazard. These signs should not be clustered together in a way where larger signs block smaller signs or where multiple instructions create information overload for the passengers.

2.1.2 TSA Instructional Signs

TSA Instructional Signs provide passengers with instructions on the screening process. These signs advise passengers on how to properly divest of their possessions and how to place those items in the bins.

These signs can be mounted in the same way as the TSA Mandatory signs or displayed on walls near the divest tables.

2.1.3 TSA Directional Signs

TSA Directional Signs instruct passengers on where to go during the screening process, including providing direction to separate queue and screening lanes. The goal is to provide clear and concise directions so that passengers react quicker and overall time in the queue is minimized. Directional signs must be elevated so they are easily visible and not hidden by passengers standing in line.

2.1.4 TSA Local Signs

TSA Local Signs are designed to meet specific local requirements, such as instructions regarding special equipment, local processing instructions, and any other signs deemed necessary by the local FSD. All local signs need to be cleared through the TSA HQ Office of Public Affairs.

Figure 2-2 SSCP Signage



2.2 QUEUE

The queue is where passengers stand in line at the front of the checkpoint on the non-sterile side. It is recommended that the queue be bound by double strap stanchions on the perimeter and single strap stanchions inside the perimeter to define the queuing lanes from the queue entrance(s) to the TDC(s)/CAT/BPSS. Queue lanes are approximately 3'-0" to 5'-0" wide depending on the queue lane function and the queue space available. Refer to **Figure 2-3** for a graphic of the types of stanchions.

TSA recommends a minimum of 300 square feet in the queue for every checkpoint lane. The queue should be big enough to meet the

peak passenger demand without interfering with other functions in the terminal such as the ticket counter or checked bag processing. A queue entrance should remain open at all times. Queues should be able to be cordoned off and funneled down to one TDC during off-peak times. 2.2.1. The exclusive use of strap stanchions is inadequate to fully secure the checkpoint. Solid barrier stanchions are required along the boundary of TDC/CAT/BPSS podium positions and the flanking side limits of the queue. The use of solid barrier stanchions is illustrated later in the guide.

Figure 2-3 Single & Double Strap Queuing Stanchions

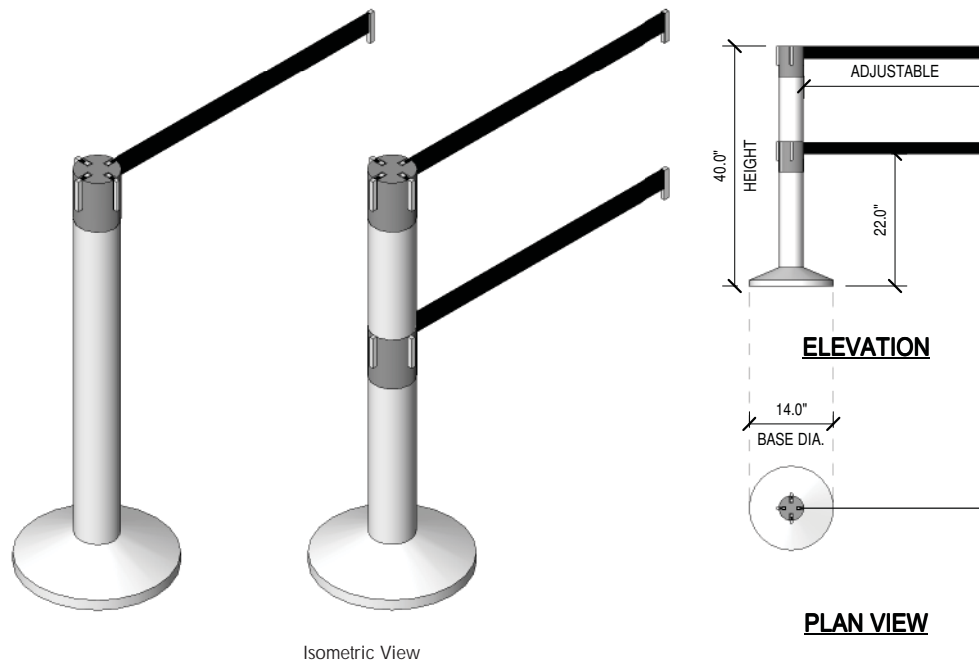
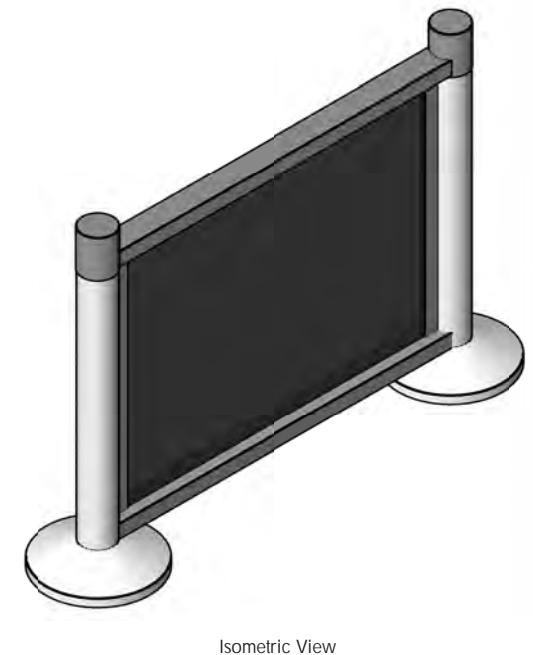

Figure 2-4 Barrier Stanchions



2.2.1 Automated Wait Time (AWT)

The TSA is in the process of testing and deploying a system that collects information and automatically calculates passenger wait time at the checkpoint queue. The AWT system utilizes information broadcasted from Bluetooth® enabled devices carried by individuals in the queue to calculate wait times and deploy resources, as appropriate, to reduce delays in the overall screening process. In order to ensure that AWT systems sustain and do not erode privacy protection, TSA has developed and implemented processes that support the Fair Information Practice Principles while generating statistical data used for improving checkpoint operations.

Wait time data is an important element in evaluating the effectiveness of the TSA staffing model in order to effectively manage checkpoint volume. In the past, TSA has used manual processes to collect wait time data. These processes are labor intensive as they utilize the screening workforce and rely on small sample sizes that lack the detail needed to generate comprehensive staffing models. Reliance on the screening workforce unnecessarily distracts screening officers from their primary function. The AWT system will not require any interaction between the TSA screening force and passengers.

The AWT system consists of the following key components (refer to **Figure 2-5**).

- Sensors
- Wait Time Server
- Flat Panel TV Screen

Sensors will be deployed throughout the queue to pick up cell phone signals of passengers in the queue. These signals will be sent to the wait time calculator or laptop computer that will be located in the supervisor's office or other TSA secure area. Sensors will also be located near the non-secure side of the X-rays to determine the time from queue entry to the exit event. The quantity and location of these sensors will be checkpoint dependent. A flat panel TV screen will be located so that passengers approaching and currently in the queue will be able to view the current wait time. The message may read: "As of 10:04 am, the wait time is 14 minutes".

TSA intends to connect each AWT system to the TSA network within months of deploying the systems. Once networked, the data can be fed continuously to TSA HQ. Until networking occurs, the field will be required to send TSA HQ a daily email with the current day's wait time data. Wait time data will be posted to www.TSA.gov for public access. Current plans call for all Category X airports to be equipped with the AWT system as well as a large number of Category 1 airports.

Figure 2-5 Typical AWT Layout

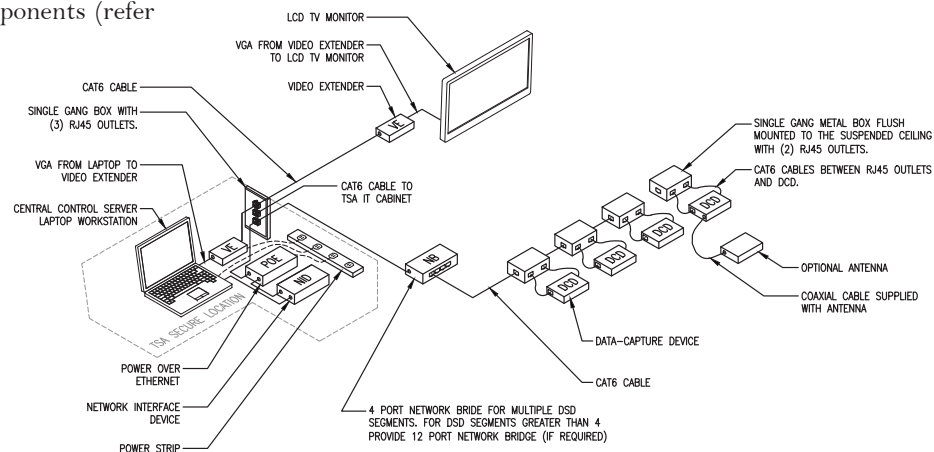

2.2.2 Travel Document Checker (TDC) & Credential Authentication Technology/Boarding Pass Scanning System (CAT/BPSS)

CAT/BPSS technology is currently being developed and is not expected to be deployed until after 2013. Please note that designers should still plan for the necessary infrastructure to be in place for checkpoints. TSA checks passenger identification and boarding passes at the exit of the queue approximately 4'-0" to 15'-0" from the screening lanes. The TDC stands or sits at a podium or a CAT/BPSS and verifies that all the necessary documents are in order. The CAT/BPSS integrates different technologies that independently verify travel documents such as paper or electronic boarding passes and passenger ID such as a driver's license or passport. The CAT/BPSS analyzes security features and barcodes on a passenger's ID and boarding pass to identify fraudulent documents. The CAT/BPSS compares the independently verified ID and travel documents to validate the passenger's identity and allow access to the screening checkpoint.

Biometric and biographic capabilities are being incorporated into this platform. Refer to **Figure 2-6** and **Figure 2-8** for additional information. The TDC function is critical to the flow of passengers through the checkpoint as it can become the bottleneck or pinch point in the passenger screening process. The queue must be set up properly to feed the TDC, and the TDC must be set up properly to feed the checkpoint lanes.

The following guidelines should be considered when determining placement of the TDC.

- The TDC, hard building walls, and stanchions (strap and solid barrier) should be setup so that NO individual can circumvent or bypass the TDC.

- The TDC should be located approximately 4'-0" to 15'-0" from the screening lanes so that passengers can cross flow to a lane of their choosing.
- Lighting should be sufficient for reading documents. Refer to Section 4.7 for lighting guidelines at the SSCP.
- There should be one TDC for every two screening lanes. Additional TDC positions should be added for odd numbered lanes and TSAPreTM.
- For checkpoints with more than three TDC positions, sufficient clearance should be provided between the queue stanchions and the TDC stanchions so that passengers can cross flow to a TDC of their choosing.

Figure 2-6 TDC Podium & CAT/BPSS



TDC Podium & Chair
Isometric View

Generic CAT/BPSS
Isometric View

- Recommended queue widths and square footage of the queue based on the number of lanes should be followed to provide for an even distribution of passengers to the TDC. Refer to Section 2.2.
- Power/data for the podium or CAT/BPSS should be provided in a recessed poke-through flush to the floor and centered under the podium or CAT/BPSS to allow for adjustment of the TDC position. When a poke-through is not possible, a power pole is acceptable.
- Alternating “mini-queues” should be created on both sides of the TDC by providing at least 5'-0" of stanchions in front of the TDC along the centerline. This will force the passengers to form two separate lines for the same TDC. The TDC will process whichever “mini-queue” passenger is ready. Refer to **Figure 2-7**.
- “Mini-queue” stanchions should be used to close TDC podiums during non-peak periods of the day.
- The stanchions that form the exterior perimeter of the TDC podium should be barrier stanchions in order to deter passengers from bypassing this function. Strap stanchions can be detached too quickly and easily where barrier stanchions have to be disassembled, alerting TSA personnel and allowing time for a TSO to respond.

Figure 2-7 TDC with Alternating-Queues “Mini-Queues”

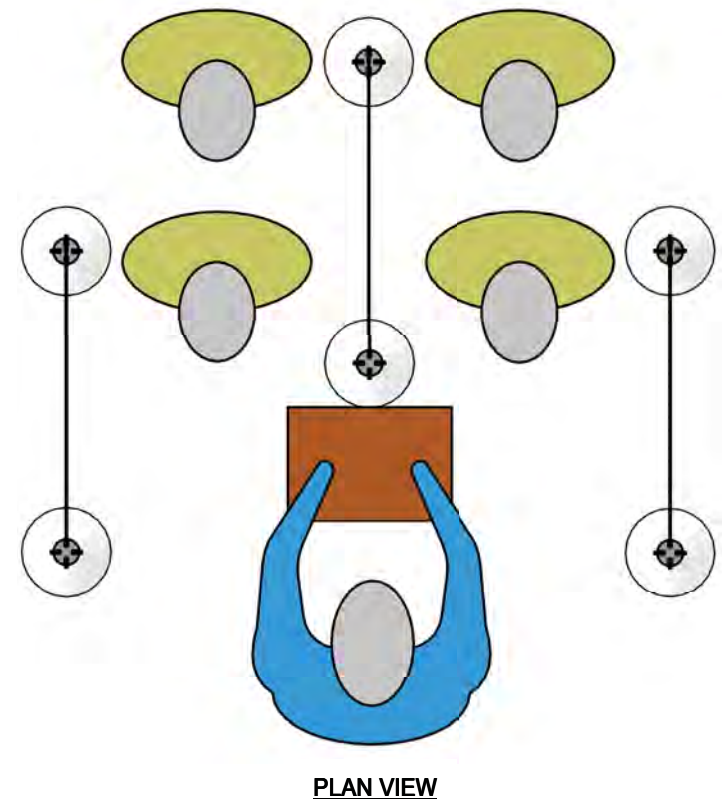
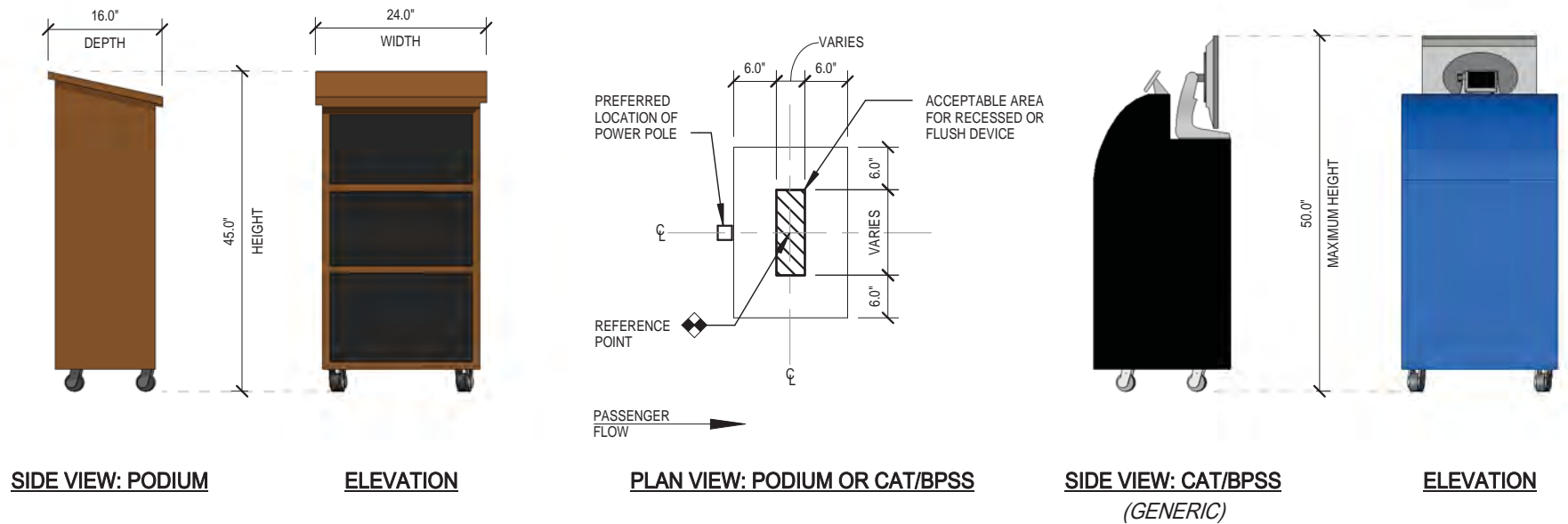

Figure 2-8 TDC Podium & CAT/BPSS

Equipment	Quantity	Power Requirements	IT Requirements	Additional Information
TDC Podium CAT/BPSS (generic)	1 per 2 lanes +1 for odd numbered lanes +1 if checkpoint feeds international flights	<ul style="list-style-type: none"> • Non-dedicated • 20A, 125V, 180VA/podium • 2-Pole, 3-Wire Grounding • NEMA 5-20R Duplex Receptacle • Power cord length is unknown at the time of this printing 	<ul style="list-style-type: none"> • Data Drops = 2 • Cat5e / Cat6 cable • The cable length from the termination point in the IT cabinet to the data outlet in the work area shall not exceed 295'. • If data drop cannot be secured when the checkpoint is closed, a locking device is required. Coordinate with TSA HQ IT Security. 	<ul style="list-style-type: none"> • The TDC function can be supported by either a TDC Podium or a CAT/BPSS. • The CAT/BPSS may be on wheels or it may sit on floor.



2.3 BIN CART

Bins are the gray containers located on a cart at the front and back of each checkpoint lane. Passengers use bins to divest themselves of their personal belongings such as purses, carry-on bags, backpacks, laptops, shoes, jackets, etc. Bin carts are similar to a hand cart or dolly that allows for the transport of a large number of bins without requiring excessive lifting or carrying by a TSA agent. In the past, bin transport by the TSOs was the primary cause of on-the-job injuries at checkpoints. Hand-carrying of bins is no longer endorsed by TSA. TSA recommends that bin carts be pushed upstream though an ADA or access gate. Ideally, an ADA or access gate should exist at every lane but this is not always possible. When there is insufficient space for an ADA or access gate, the bin cart should be pushed upstream against passenger flow through the WTMD.

Bin carts can be one or two bins wide with bins stacked on top to slightly below the handle which equates to approximately 40 bins. Each lane requires a bin cart at each end. TSA recommends maintaining about 60 bins per lane divided across each end. A fully-loaded bin cart should be located at the start of the divest tables on

the non-sterile side of the lane for passenger pick-up. The other bin cart should be positioned at the end of the composure rollers on the sterile side so that the TSA agent can collect empty bins after passengers have picked up their belongings. Refer to **Figure 2-9** for bin cart dimensions. The bin cart width times two should be factored into the overall length of the checkpoint lane when designing a new checkpoint or reconfiguring an existing checkpoint.

Figure 2-9 Bin Cart

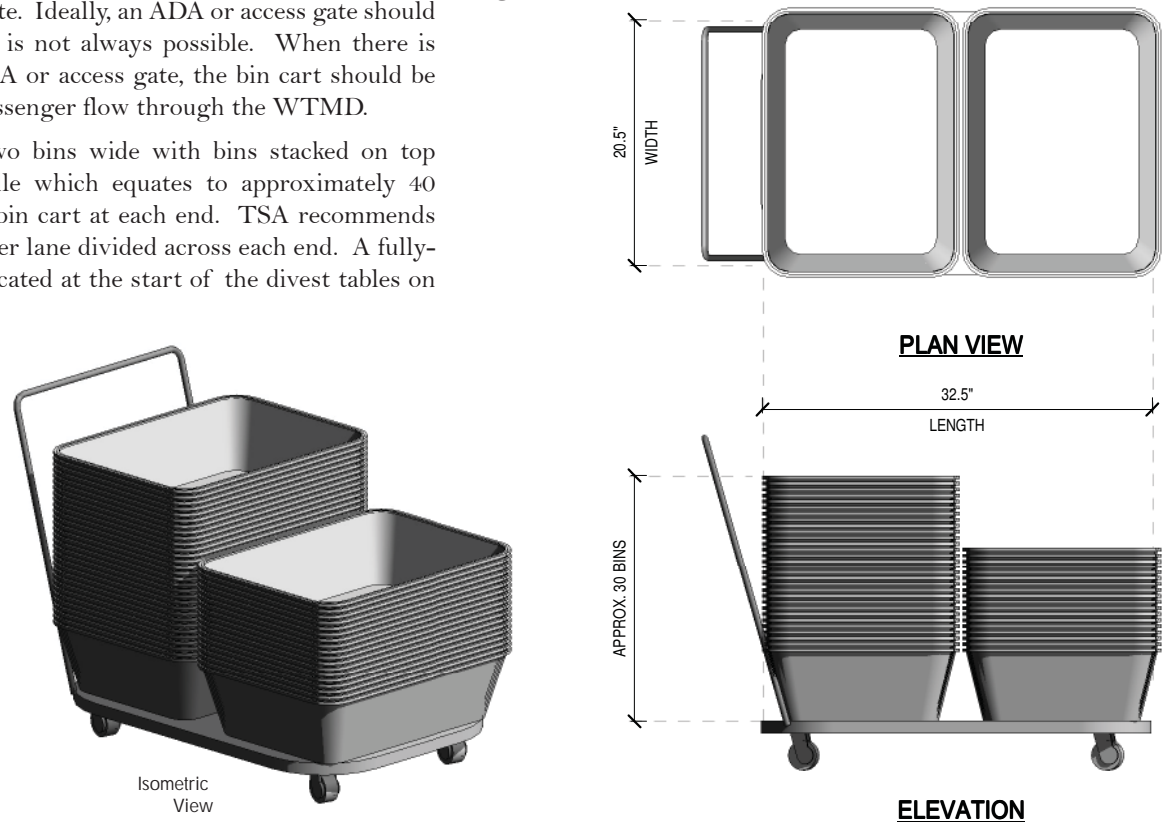

2.4 DIVEST TABLE

Divest tables are provided for passengers to stage their bins side-by-side so they can deposit their personal items into the bins. The divest table allows passengers to slide their bins to the infeed of the X-ray. Current checkpoints utilize a variety of table sizes and types. However, for new checkpoints or checkpoints being reconfigured, the divest tables are 30" wide and 60" or 72" long. See **Figure 2-10**. Two 72" tables abutted to the infeed roller or loading table of the X-ray is the preferred divest length, but limited checkpoint depth

or obstructions may require shorter tables or only one table. Divest tables are stainless steel with height-adjustable legs from 27" to 32". Implementation of these tables will increase sequencing efficiency through the checkpoint. Lanes that do not have enough depth for 12'-0" of passenger divesture will have a slower throughput.

Figure 2-10 Divest Table

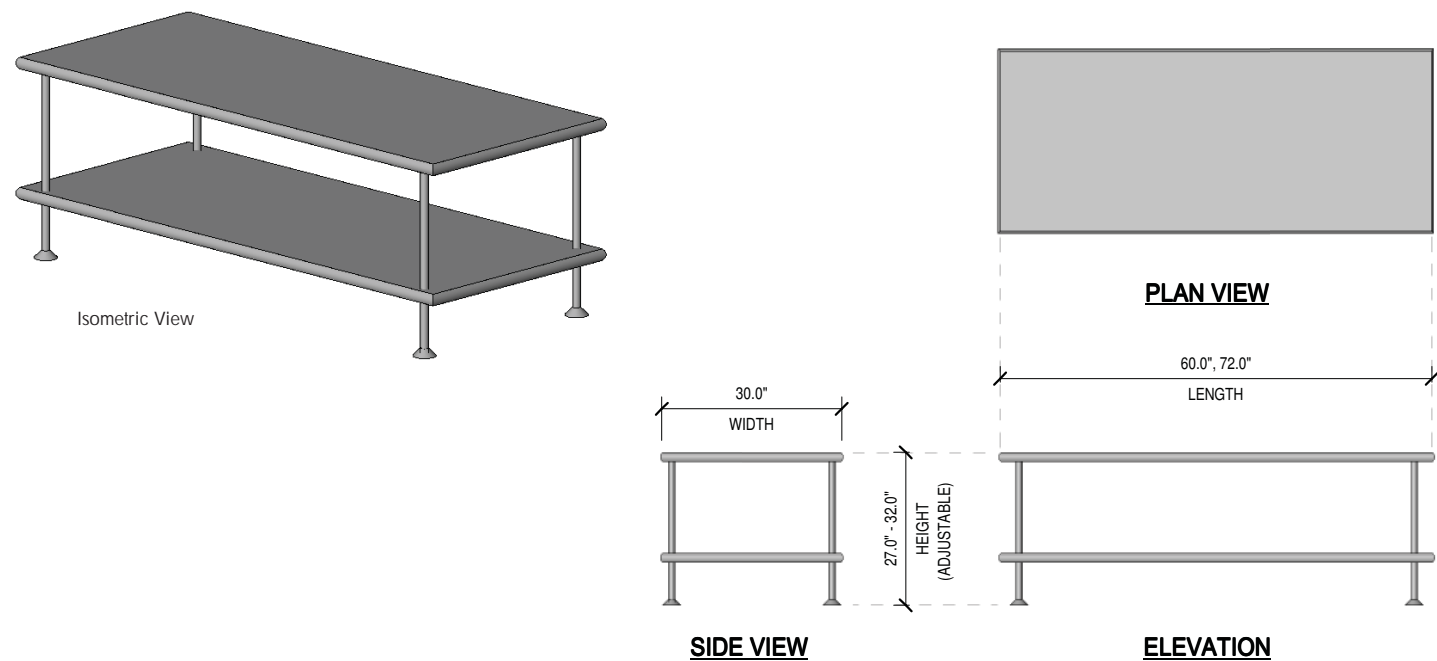

2.5 CARRY-ON BAG SCREENING

Carry-on bag screening is mandatory at an SSCP. It can be accomplished by deploying AT1, AT2, or AutoEDS equipment. Generally, this equipment has the following components.

- Loading Table/Entrance Roller
- Queuing Conveyor & Hood (Vendor Specific AT2 Only)
- Scanning Belt & Dome
- High Speed Conveyor (HSC) & Hood
- Extension Rollers
- Exit Roller with Bag Stop
- Manual Diverter Roller (MDR) (AT2 only)
- Alternate Viewing Station (AVS) (AT2 only)

TSOs are staffed dynamically at the carry-on bag screening units where one or two screeners can perform the functions listed below.

- Review bag images on the monitors
- Remove alarmed bags from the alarm bag cutout or from the MDR
- Place empty bins on the bin carts
- Transport empty bins from the sterile side through the ADA/ access gate or WTMD to the non-sterile side

Interpreting the bag images on the monitor requires focused concentration by the TSO. The operator should have an ergonomic and distraction-free environment. The space should be designed to minimize glare on the X-ray workstation monitors from interior lighting, glass walls, or sunlight. The monitor height should be at an optimum viewing angle. The operator must also have a clear view of the machine's entrance and exit conveyor. Columns, power poles, signage, etc. should not prevent the TSO from seeing the bags going in and out of the X-ray unit.

Equipment determination for each lane at an SSCP will be based on the space available, the required number of lanes based on passenger load, and the floor structure. If the checkpoint is being reconfigured, additional consideration needs to be given to the location of the existing electrical outlets, TSO familiarity with a specific manufacturer, and existing maintenance contracts. The TSA HQ POC, local FSD staff, and the checkpoint designer will need to work together to determine the best solution based on the site conditions.

Carry-on bag screening equipment may have panic buttons/duress alarms installed by the airport directly on the equipment or near the equipment operator. These alarms are typically connected to the airport or local law enforcement. Checkpoint designers should refer to the Airport Security Plan if relocation of panic buttons is required.

Equipment discussed in this section covers all primary carry-on bag screening. Alarmed bags may require secondary screening, which is discussed in Section 2.11.

2.5.1 Advanced Technology (AT) X-Ray

The AT X-ray is the next generation of X-ray equipment that will replace the TRX. The AT X-ray is wider, longer, heavier, and draws more power than its TRX counterpart. Refer to **Figure 2-11**. This larger size improves the screening capability by capturing a bottom and side view of carry-on bags inside the dome and producing two high resolution images for TSA to review. TSA currently classifies the AT equipment as either AT1 or AT2. AT1 represents the first deployment of the AT units which consisted of the Rapiscan 620DV and the Smiths 6040aTiX. AT2 represents the second deployment of the AT units which consists of the Rapiscan 620DV, the Smiths 6040aTiX, and the L3 ACX 6.4-MV. Basically, AT2 is AT1 with modifications based on new TSA requirements. AT2 includes the addition of an Alternate Viewing Station (AVS) and, in the case of Rapiscan and L3, the addition of a 48" queuing conveyor between the infeed roller and the scanning belt. **Figure 2-12**, **Figure 2-14**, and **Figure 2-16** depict the Rapiscan, Smiths, and L3 AT product specifications. Standard layouts with the Rapiscan AT are reflected in Section 3.0.

The Rapiscan and Smiths AT come standard in a RH configuration but they can be modified into a LH configuration. The L3 AT comes standard in a LH configuration only. The standard configurations are shown on the plan views on the following pages. Unlike the TRX, the "hand" is dependent on the bump-out orientation rather than the operator. The bump-out is the side bonnet on the AT X-ray that juts out from the rectangular shape. This is where the side view camera is located. On a RH unit, the bump-out is on the right side of the AT dome when standing on the non-sterile side of the AT looking at the infeed tunnel. On a LH unit, the bump-out is on the left side of the AT dome when standing on the non-sterile side of the AT looking at the infeed tunnel. The RH and LH AT units are not symmetrical. The LH AT is a 180° rotation of the RH AT with the infeed and outfeed components interchanged. On the RH AT, the side view picture is taken last; whereas on the LH AT, the side view

picture is taken first. The bump-out orientation should be specified prior to manufacturer.

The operator workstation can be located on either the bump-out or the nonbump-out side. This is often referred to as bump-outs towards operators or bump-outs towards passengers, respectively. Even though the Rapiscan and L3 AT have a "tethered" independent operator workstation, the location still needs to be determined prior to manufacture. The Smiths AT operator workstation is located on a cart.

In summary, there are four possible configurations of the Rapiscan and Smiths AT, and two possible configurations of the L3 AT. It is important to identify the orientation of the bump-out and the location of the operator early on so that it can be manufactured as designed as it is arduous and expensive to change in the field. The orientations are as follows.

Rapiscan 620DV AT and Smiths 6040aTiX AT Configurations:

- RH AT with bump-out towards operator
- RH AT with bump-out towards passengers
- LH AT with bump-out towards operator
- LH AT with bump-out towards passengers

L3 ACX 6.4-MV AT Configurations:

- LH AT with bump-out towards operator
- LH AT with bump-out towards passengers

The AT units are also unique in regard to the composure length. The Rapiscan 620DV and L3 ACX 6.4-MV have one 1-meter (3'-3") extension roller with a bag stop. The Smiths 6040aTiX has one 6'-8" exit roller with a bag stop. AT compatible TRX or AT extension rollers should be added to obtain the recommended composure length of 12'-0". Extension rollers are discussed further in Section 2.5.3.

The AVS is where a TSO can recall the image of an alarmed bag from the AT2 while performing a target bag search. For the Rapiscan and L3 AT, the AVS is mobile operator cart that is located approximately 18" to 22" off the back side of a TSA-provided search table. The cart has one or two monitors, a keyboard, and a PC tower that can be plugged into the power strip that is mounted to the TSA search table. The power strip is plugged into a device that feeds the ETD and BLS at the secondary screening area. The Smiths AVS has two monitors and a keyboard attached to an arm that is connected to the Smiths-provided search table. The search table also acts as a cabinet that houses the PC and UPS. **Figure 2-13, Figure 2-15, and Figure 2-17** depict the Rapiscan, Smiths, and L3 AVS product specifications.

Figure 2-11 AT Units

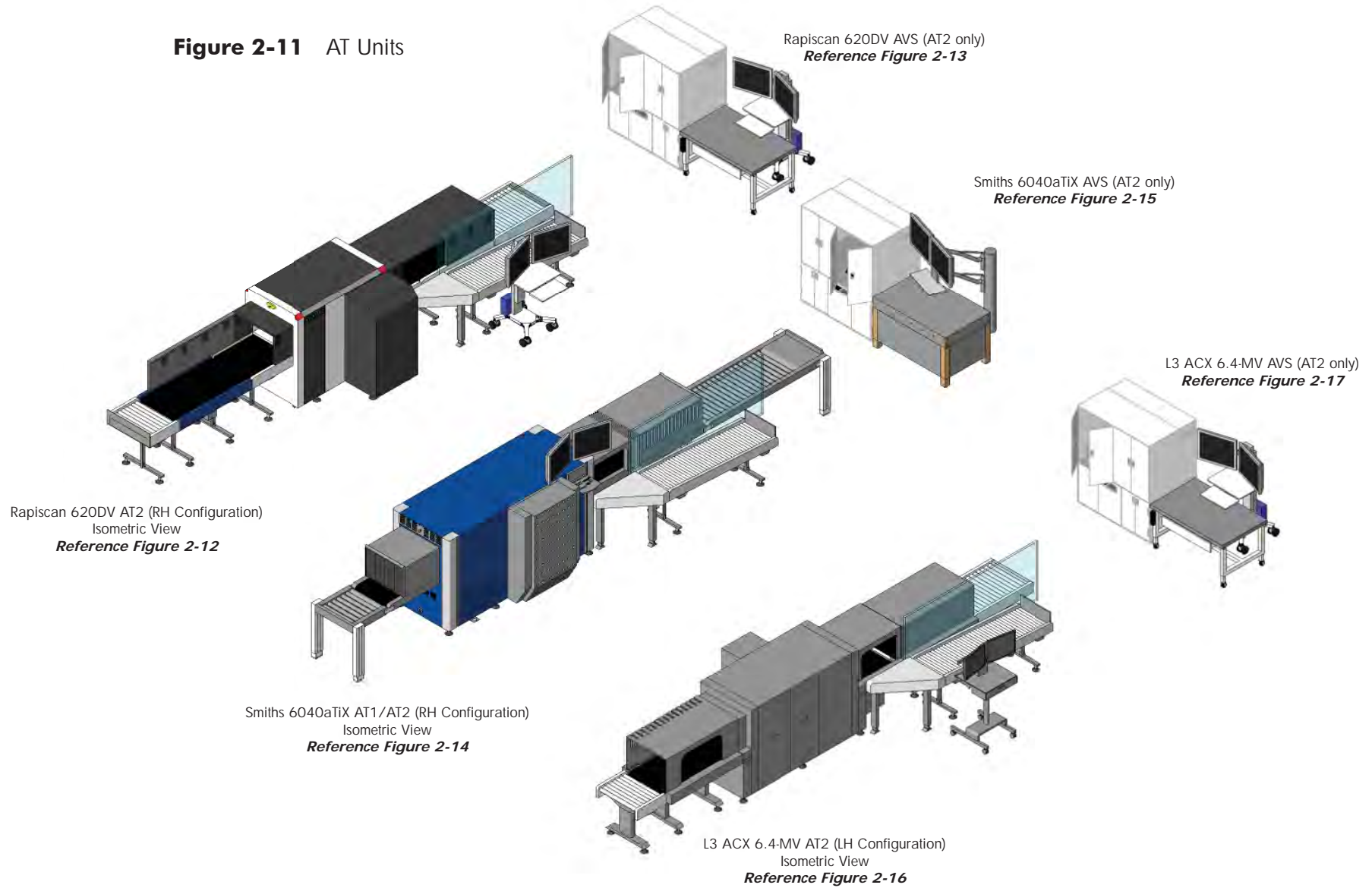

Figure 2-12 AT - Rapiscan

Equipment	Quantity	Power Requirements	IT Requirements	Additional Information
Rapiscan 620DV AT1	1 per lane	<ul style="list-style-type: none"> Dedicated 20A, 125V, 1800VA/unit 2-Pole, 3-Wire Grounding NEMA 5-20R Simplex Receptacle 15' power cord from the AT to the receptacle 	<ul style="list-style-type: none"> Data Drops = 2 Cat5e / Cat6 cable The cable length from the termination point in the IT cabinet to the AT data outlet shall not exceed 295'. All data cabling must be provided by others. Not supplied by vendor. 	<ul style="list-style-type: none"> Rapiscan 620DV comes in a RH (shown) or LH configuration. The LH unit is a 180 degree rotation of the RH unit. Power and data connections are reversed for a LH unit. Rapiscan uses an Ergotron Dual Stand for the AT mobile operator cart and AVS. The operator cart is attached by a vendor provided data cable and can move freely around the unit. Weight: <ul style="list-style-type: none"> » 2,094 lbs. The HSC can be sloped downwards no more than 12 degrees and upwards no more than 10 degrees.
Rapiscan 620DV AT2	1 per lane	<ul style="list-style-type: none"> Refer to AT1 for main unit power. Dedicated for queuing conveyors only, maximum of 4 per circuit 20A, 125V, 360VA/unit 2-Pole, 3-Wire Grounding NEMA 5-20R Simplex Receptacle 15' power cord from the queuing conveyor to the receptacle 	<ul style="list-style-type: none"> Refer to AT1 	<ul style="list-style-type: none"> AT2 is AT1 with a queuing conveyor and an AVS. The queuing conveyor and HSC can be sloped downwards no more than 12 degrees and upwards no more than 10 degrees.

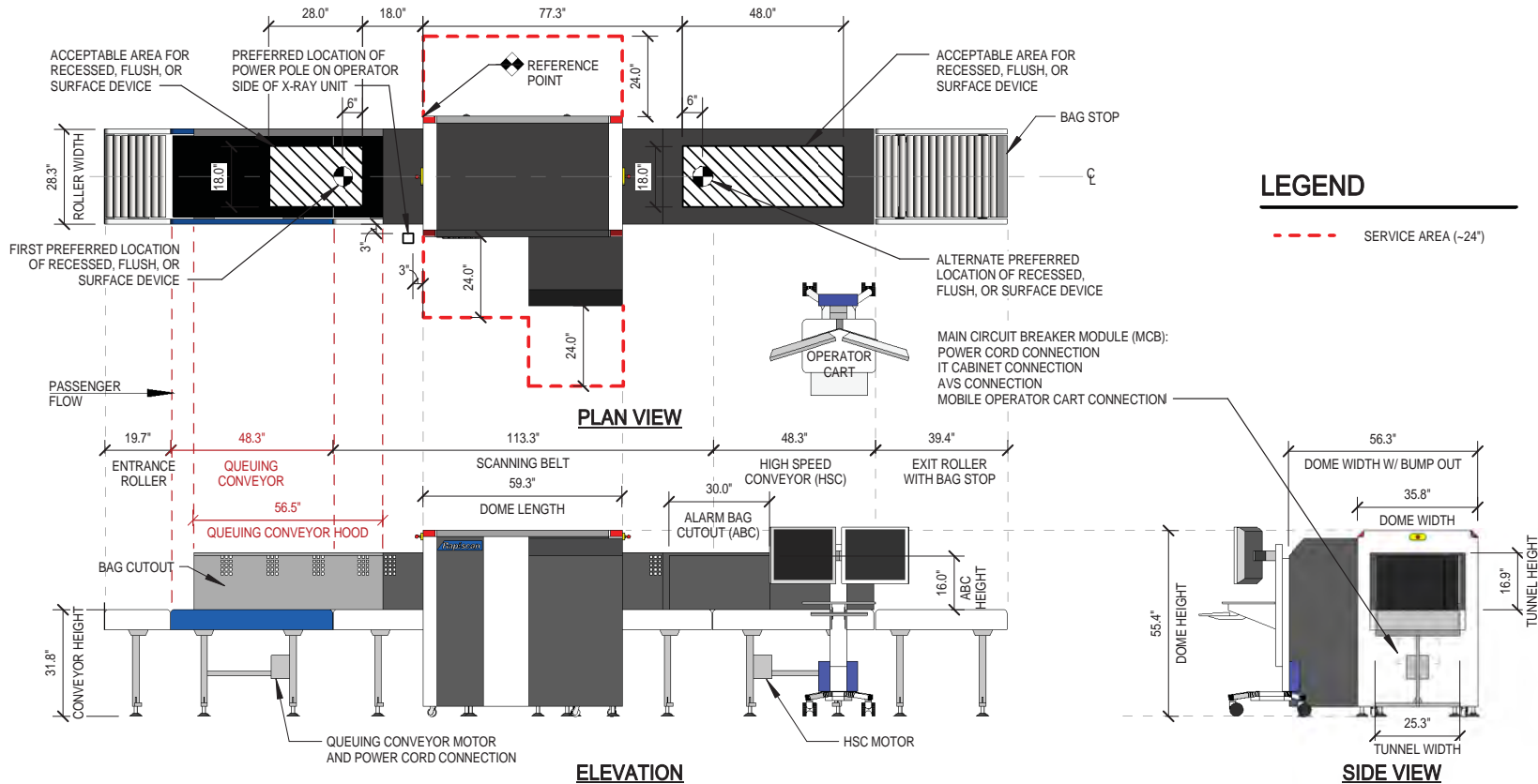

Figure 2-13 AVS - Rapiscan

Equipment	Quantity	Power Requirements	IT Requirements	Additional Information
Rapiscan 620DV AVS	1 per AT2	<ul style="list-style-type: none"> Non-Dedicated, shared with ETD and BLS circuit at the same search area 15A, 125V, 252VA/unit, 504VA/2 units 2-Pole, 2-Wire Grounding NEMA 5-20R Receptacle 5' power cord for two monitors and one PC tower of the AVS to the power strip mounted to the TSA search table. 6' power cord from the power strip to the receptacle 	<ul style="list-style-type: none"> 49' Cat5e cable from the MCB located at the secure end of a RH AT or the non-secure end of a LH AT to the AVS. All data cabling must be provided by others. Not supplied by vendor. 	<ul style="list-style-type: none"> AVS is an Ergotron Dual Stand. Located with standard TSA search table.

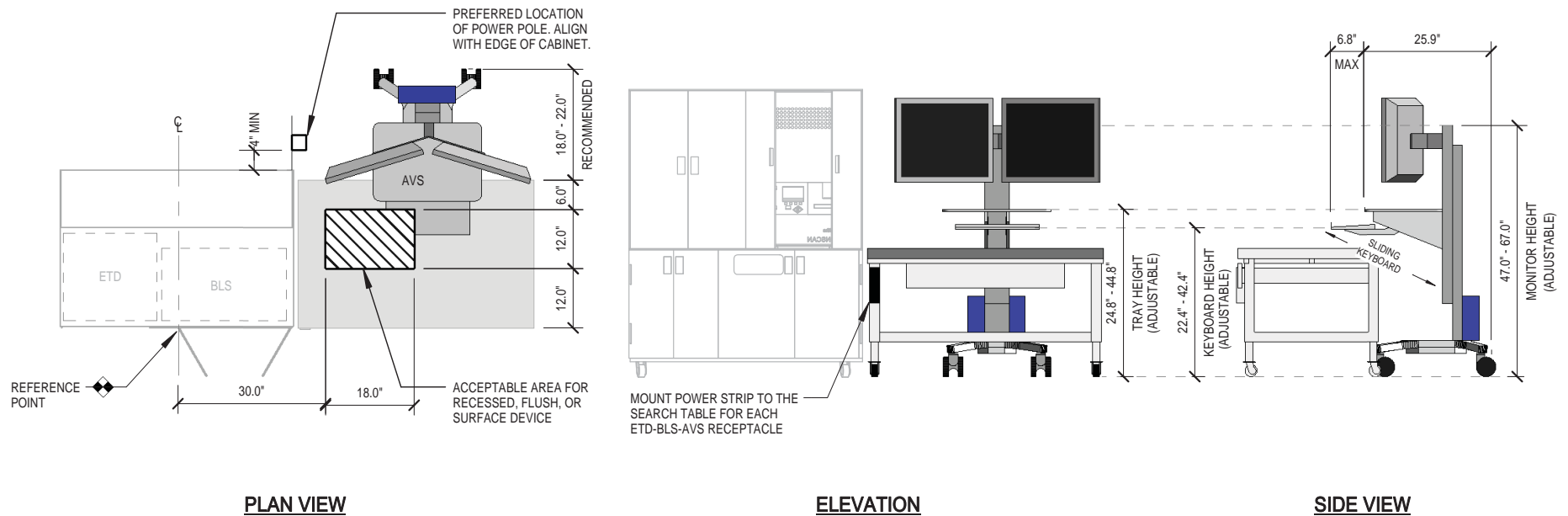

Figure 2-14 AT - Smiths

Equipment	Quantity	Power Requirements	IT Requirements	Additional Information
Smiths 6040aTiX AT1/ AT2	1 per lane	<ul style="list-style-type: none"> Dedicated 20A, 125V, 1920VA/unit 2-Pole, 3-Wire Grounding NEMA 5-20R Simplex Receptacle 15' power cord from the AT to the receptacle 	<ul style="list-style-type: none"> Data Drops = 2 Cat5e / Cat6 cable The cable length from the termination point in the IT cabinet to the data outlet in the work area shall not exceed 295'. All data cabling must be provided by others. Not supplied by vendor. 	<ul style="list-style-type: none"> Smiths 6040aTiX comes in a RH (shown) or LH configuration. The LH unit is a 180 degree rotation of the RH unit. Power and data connections are reversed for a LH unit. The operator workstation is mounted to the X-ray. Existing field equipment may have the operator workstation located on a cart. Weight: <ul style="list-style-type: none"> » 3,528 lbs.

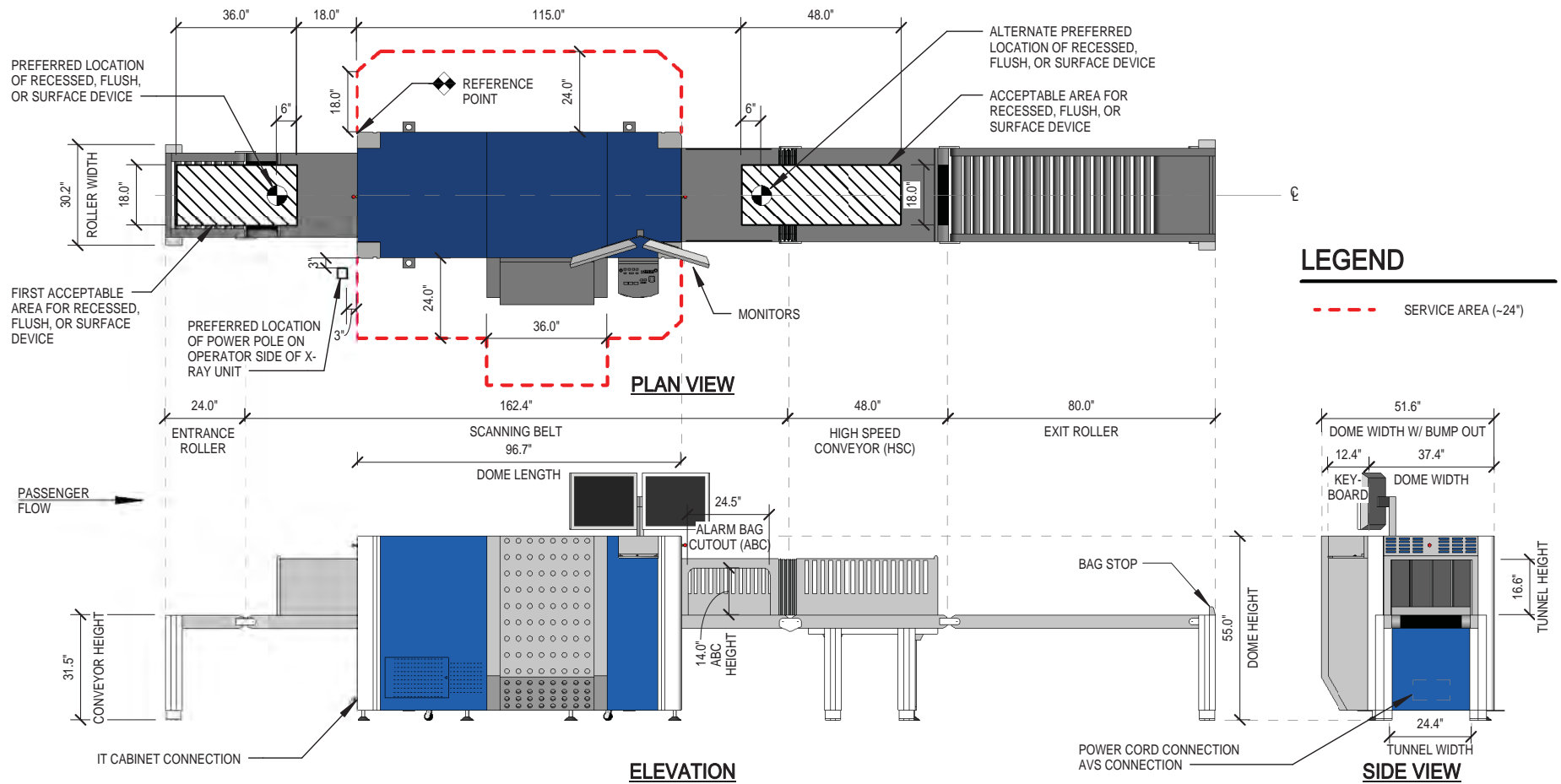

Figure 2-15 AVS - Smiths

Equipment	Quantity	Power Requirements	IT Requirements	Additional Information
Smiths 6040aTiX AVS	1 per AT2 Unit	<ul style="list-style-type: none"> • Non-Dedicated, shared with ETD and BLS circuit at the same search area • 10A, 125V, 144VA/unit, 288 VA/2 units • 2-Pole, 2-Wire Grounding • NEMA 5-20R Receptacle • 5' power cord for two monitors and one PC tower of the AVS to the power strip provided by the installing contractor for the Smiths search table. • 6' power cord from the power strip to the receptacle 	<ul style="list-style-type: none"> • All data cabling must be provided by others. Not supplied by vendor. 	<ul style="list-style-type: none"> • Search table provided by vendor.

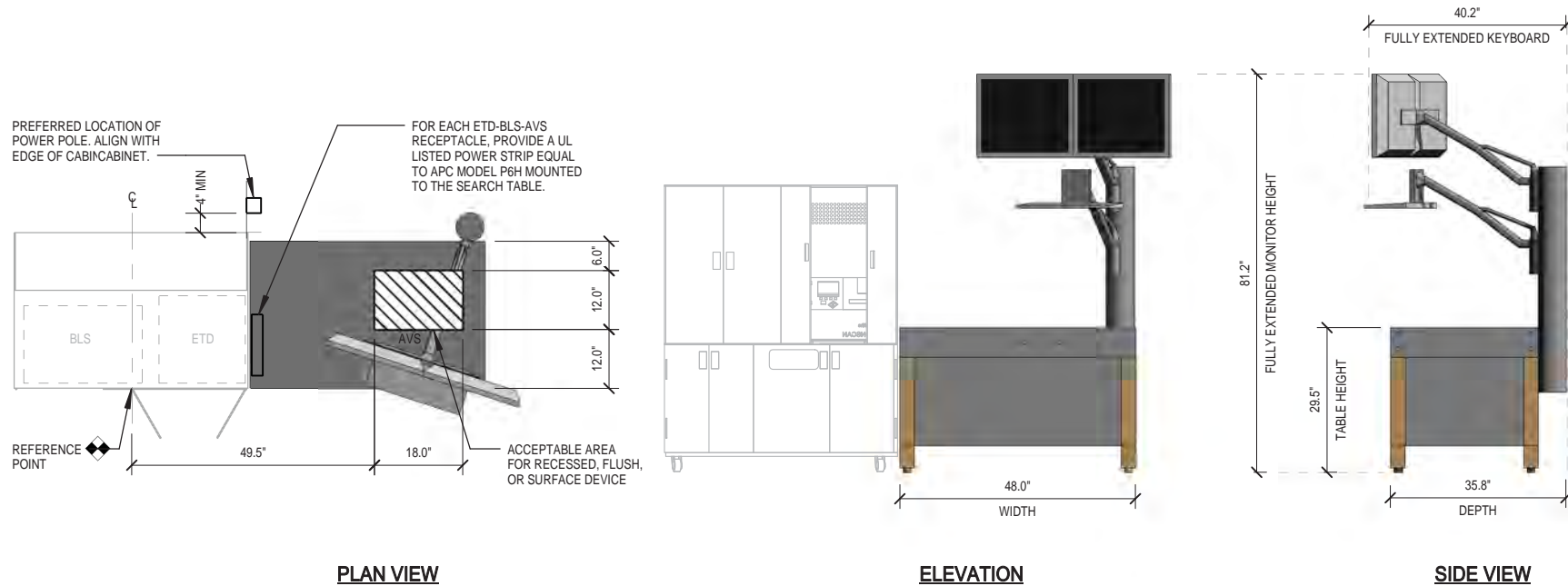

Figure 2-16 AT - L3

Equipment	Quantity	Power Requirements	IT Requirements	Additional Information
L3 ACX 6.4-MV AT2	1 per lane	<ul style="list-style-type: none"> • AT2: <ul style="list-style-type: none"> » Dedicated » 20A, 125V, 1850 VA/unit » 2-Pole, 3-Wire Grounding » NEMA 5-20R Simplex Receptacle » 15' power cord from the AT to the receptacle » The operator cart is powered by the AT. 	<ul style="list-style-type: none"> • Data Drops = 2 • The cable length from the termination point in the IT cabinet to the data outlet in the work area shall not exceed 295'. • Two 17' Cat5 cables from the AT2 to the operator cart. • Two 25' Cat5 cables from the AT2 to the two switches of the FDRS. • Two 5' Cat5 cables from the two switches to the FDRS. 	<ul style="list-style-type: none"> • L3 AT2 comes in LH configuration only. The operator may sit on either side of the unit. • Weight: <ul style="list-style-type: none"> » 2,260 lbs. • The operator cart can move freely around the unit.

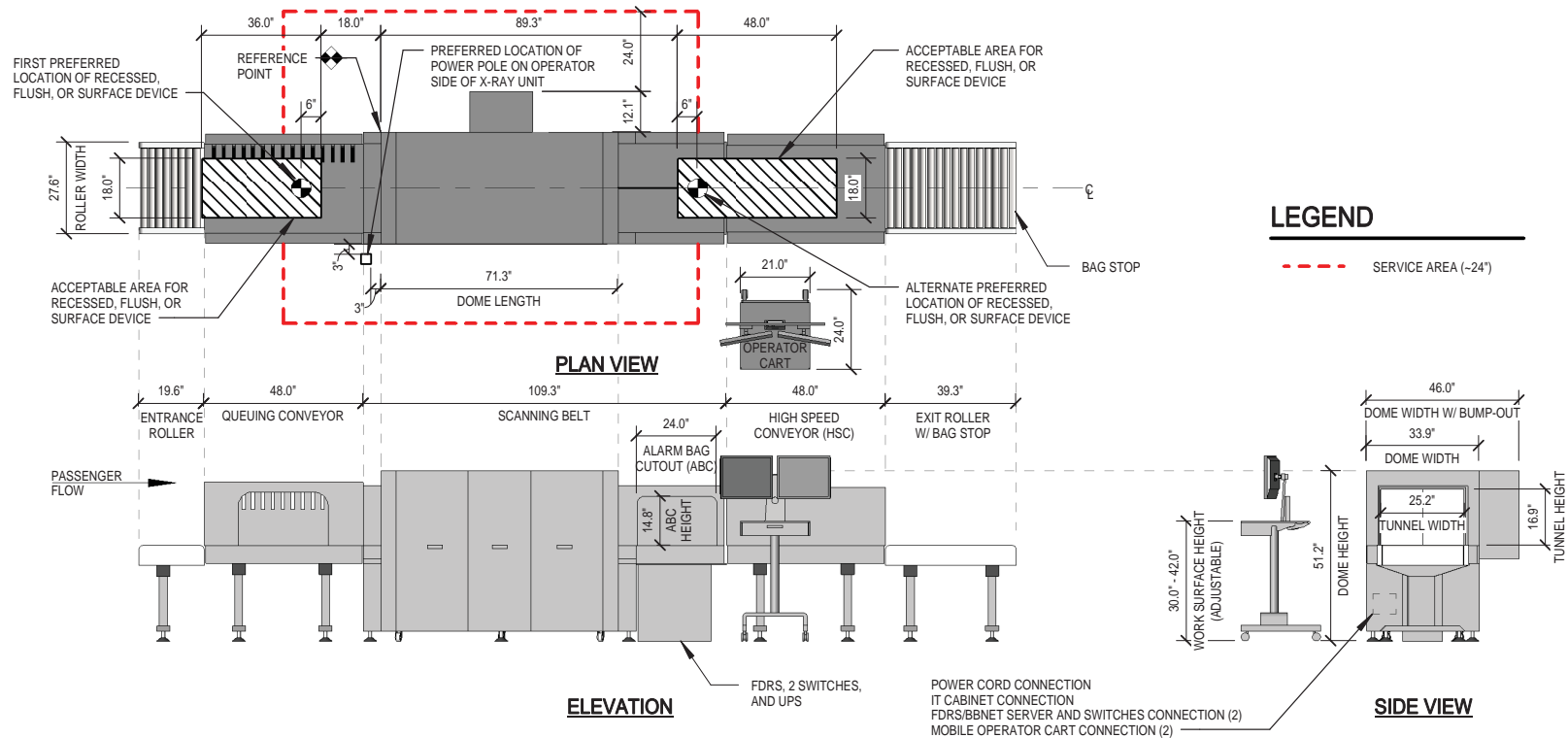
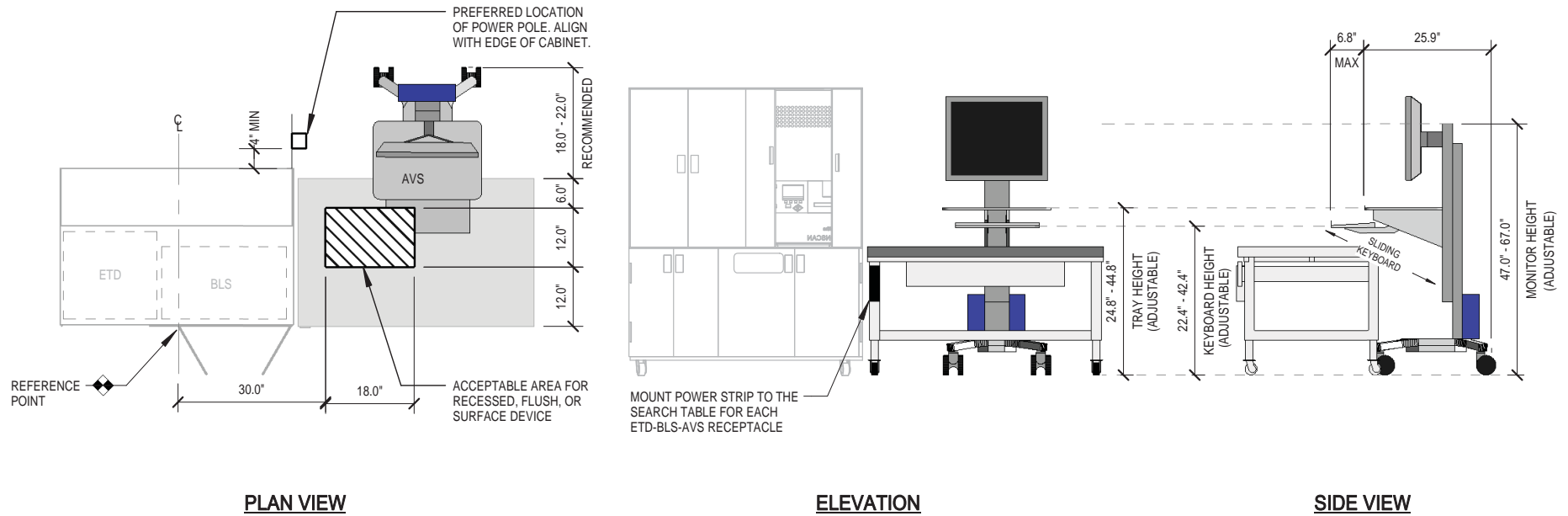

Figure 2-17 AVS - L3

Equipment	Quantity	Power Requirements	IT Requirements	Additional Information
L3 ACX 6.4-MV AVS	1 per AT2 Unit	<ul style="list-style-type: none"> AVS: <ul style="list-style-type: none"> Non-Dedicated, shared with ETD and BLS circuit at the same search area 6.3A, 125V, 420VA/unit, 840 VA/2 units 2-Pole, 3-Wire Grounding NEMA 5-20R Receptacle 6' power cord from the monitor and PC tower of the AVS to the UPS UPS (750VA Rating): <ul style="list-style-type: none"> Non-Dedicated 6.3A, 120V, 758VA/unit 2-Pole, 3-Wire Grounding NEMA 5-20R Receptacle 6' power cord from the UPS to the power strip mounted to the TSA search table. Longer cord lengths are available from the vendor. 6' power cord from the power strip to the receptacle 	<ul style="list-style-type: none"> All data cabling must be provided by others. Not supplied by vendor. 	<ul style="list-style-type: none"> AVS is an Ergotron single monitor stand. Located with standard TSA search table.



2.5.2 Manual Diverter Roller (MDR)

The MDR is a non-powered, gravity fed, stand-alone roller located on the operator side of any AT2 unit at the alarm bag cutout. See **Figure 2-18**. The MDR comes in a RH or LH configuration which is determined by the side of the dome it is located on when standing on the non-sterile side of the AT looking at the infeed tunnel. The AT2 operator will be able to slide alarmed bags onto the MDR so that

bags can be taken to the secondary screening area to be investigated by a TSO. The MDR has a Plexiglas® partition that prevents passengers from accessing their alarmed bags from the other side of the composure/extension rollers. The MDR slope and height can be adjusted to align with any AT2.

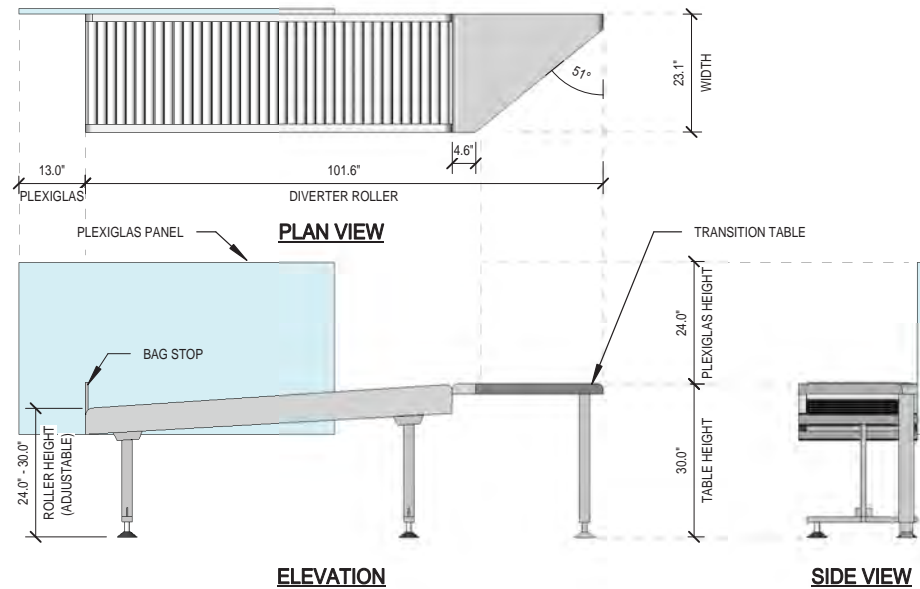
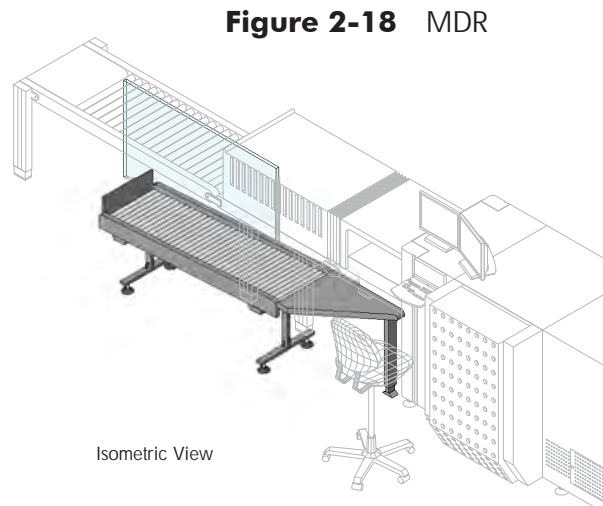

THE MDR ALIGNS WITH THE ALARM BAG CUTOUT ON THE OPERATOR SIDE. THE MDR NEEDS TO BE SPECIFIED AS RH OR LH DEPENDING ON WHICH SIDE THE ABC IS WHEN STANDING ON THE NON-STERILE SIDE LOOKING AT THE INFEED TUNNEL.

2.5.3 Composure/Extension Rollers

The TRX and AT units have a High Speed Conveyor (HSC) covered by a tunnel located directly after the scanning belt. A carry-on bag arrives at the HSC after the bag has cleared the image review by the TSO. The HSC carries cleared bags to the composure/extension rollers where passengers can retrieve their personal items. These rollers are either called composure/extension rollers or exit rollers depending on the vendor and where they are installed on the TRX or AT. **Figure 2-19** represents a variety of composure/extension rollers that are used today. They attach to the HSC to create length at the back end of the X-ray so passengers can clear the confined screening area and have a more open environment for retrieving their personal belongings and composing. Without extension rollers, bottlenecks would exist at the HSC exit, and passengers would be unable to bypass congestion.

TSA recommends a minimum of 12'-0" of composure length which can be a combination of extension rollers or exit rollers depending on the manufacturer of the TRX or AT. The Rapiscan TRX, Rapiscan AT, and the L3 AT extension rollers come in 1-meter (3'-3") lengths. The Smiths TRX and AT extension rollers come in 48" and 72" lengths. The Rapiscan 520B 1-meter extension roller is compatible with the Rapiscan 620DV AT. The Smiths 6040i 48" and 72" extension rollers are compatible with the Smiths 6040aTiX. Exact dimensions of each extension roller are reflected in **Figure 2-20**, **Figure 2-21**, and **Figure 2-22**.

Figure 2-19 Composure/Extension Rollers

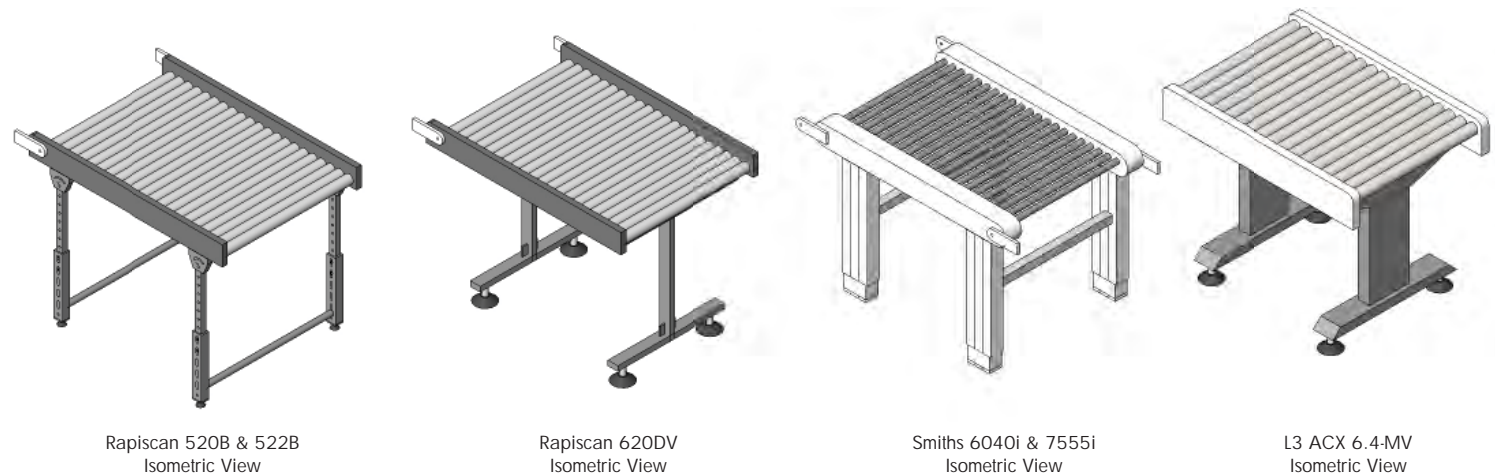
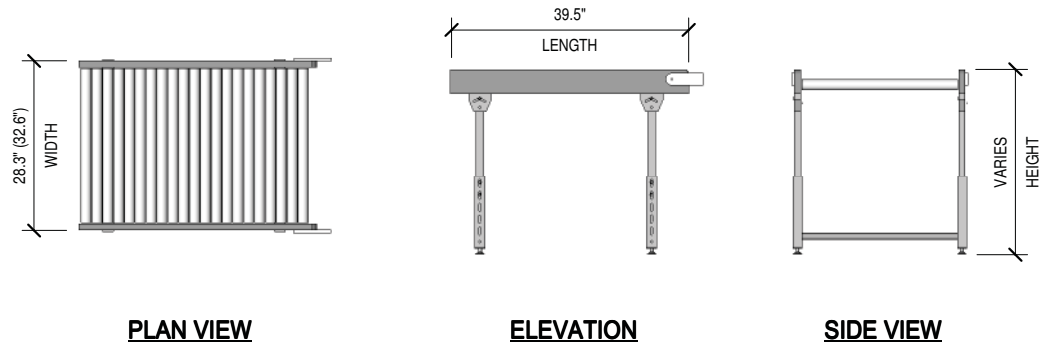

Figure 2-20 Rapiscan Composure/Extension Rollers

TRX Extension Rollers
 Rapiscan 520B
 Rapiscan 522B



NOTE: DIMENSIONS SHOWN ARE FOR THE RAPISCAN 520B AND 522B. WHERE VALUES DIFFER, DIMENSIONS FOR THE 522B ARE SHOWN IN (PARENTHESIS).
 RAPISCAN 520B ROLLER IS COMPATIBLE WITH THE RAPISCAN 620DV AT.

AT Extension Rollers
 Rapiscan 620DV

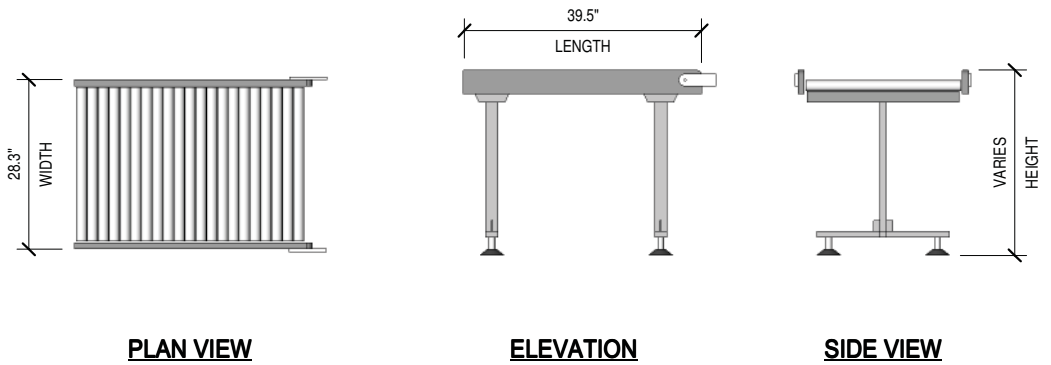
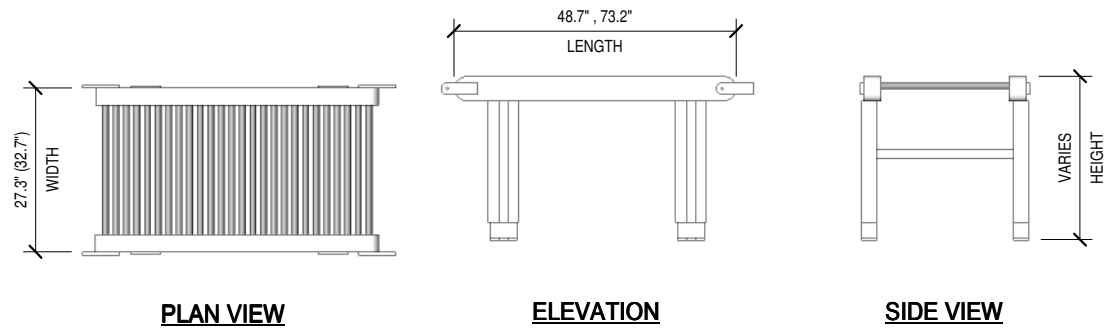

Figure 2-21 Smiths Composure/Extension Rollers

TRX Extension Rollers
Smiths 6040i
Smiths 7555i



NOTE: DIMENSIONS SHOWN ARE FOR THE SMITHS 6040i AND 7555i. WHERE VALUES DIFFER, DIMENSIONS FOR THE 7555i ARE SHOWN IN (PARENTHESIS).
SMITHS 6040i ROLLER IS COMPATIBLE WITH THE SMITHS 6040aTIX AT.

Figure 2-22 L3 Composure/Extension Roller

AT Extension Roller
L3 ACX 6.4-MV

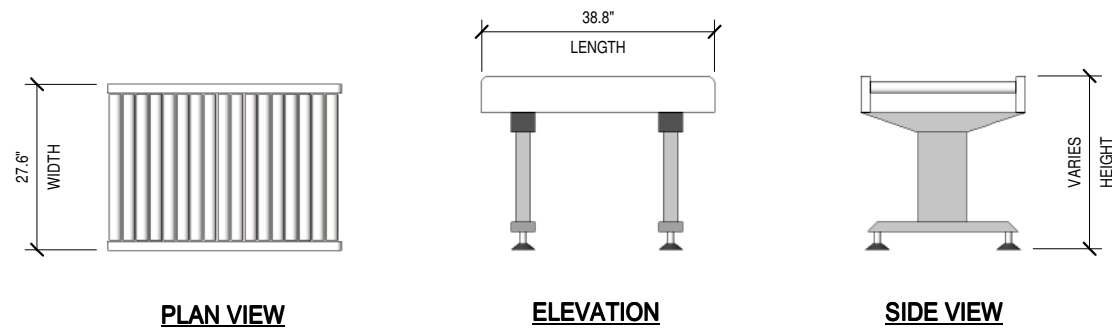

2.6 WALK THROUGH METAL DETECTOR (WTMD)

The WTMD is used for passenger screening. It is an archway used to detect concealed metallic weapons and/or contraband. Refer to **Figure 2-23** for an isometric view of the WTMDs currently located in the field. CEIA is the most common WTMD. CEIA specifications can be found in **Figure 2-24**. Currently, the original equipment manufacturer (OEM) and Siemens are certified and authorized by TSA to relocate, recalibrate, service, and relocate the power cord to the opposite leg of the WTMD.

In order to minimize environmental and equipment interference with the WTMD, the following guidelines should be applied.

- Align the entrance of the WTMD so that it is 1'-6" behind the leading edge of the TRX or AT queuing conveyor hood and center between the TRX or AT if it is a 2-lane set and not co-located with an AIT.
- Provide power/data from a lane adjacent to the WTMD where there is no passenger flow between the TRX or AT and the WTMD. The power and data connections can originate from either leg of the WTMD and can be modified in the field by the OEM or Siemens if a checkpoint requires that the WTMD be powered from the opposite lane.
- Provide approximately 12" clearance from the legs to all other equipment, walls, or columns to prevent operational interference. Non-metallic ancillary equipment such as barriers and ADA gates can be spaced 2" to 9" from the WTMD legs.
- Locate a WTMD a minimum of 18 inches from all electrical fields created by escalators, trains, conveyors, neon fixtures, speakers, transformers, banks of electrical circuit breakers, conduit, wire, and receptacles both overhead and beneath the floor.
- Minimize interference from metal in surrounding architecture, including floors, floor supports, doors, metallic framing, wall studs, façade systems, columns, etc.
- Avoid locating the WTMD across expansion joints or in an area

prone to surface vibrations created by equipment above, below or immediately adjacent to the checkpoint such as baggage conveyors, subway trains, heavy truck traffic, etc.

- Provide twistlock receptacles to prevent the WTMD from being accidentally disconnected which drains the back-up battery.
- Secure the 13'-0" cord tight to the barrier on the sterile side adjacent to the WTMD to prevent the cord from being run across passenger egress or TSA work paths where the cord is likely to be a trip hazard or become damaged.
- Silicone or bolt the WTMD to the floor.
- The WTMD cannot be closer than 24" from the x-ray.

Figure 2-23 WTMD Units

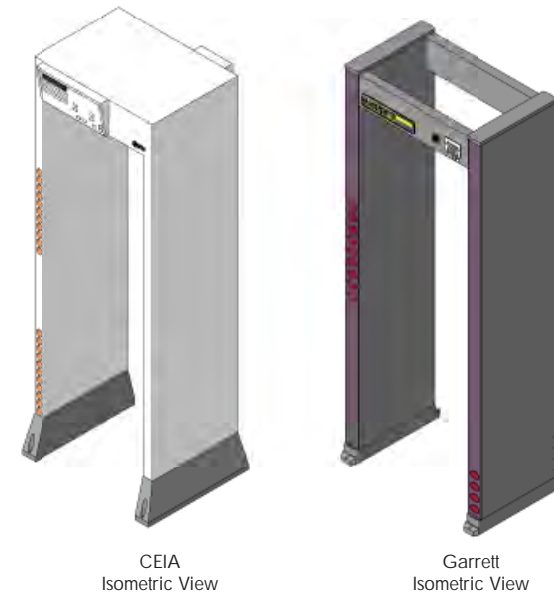
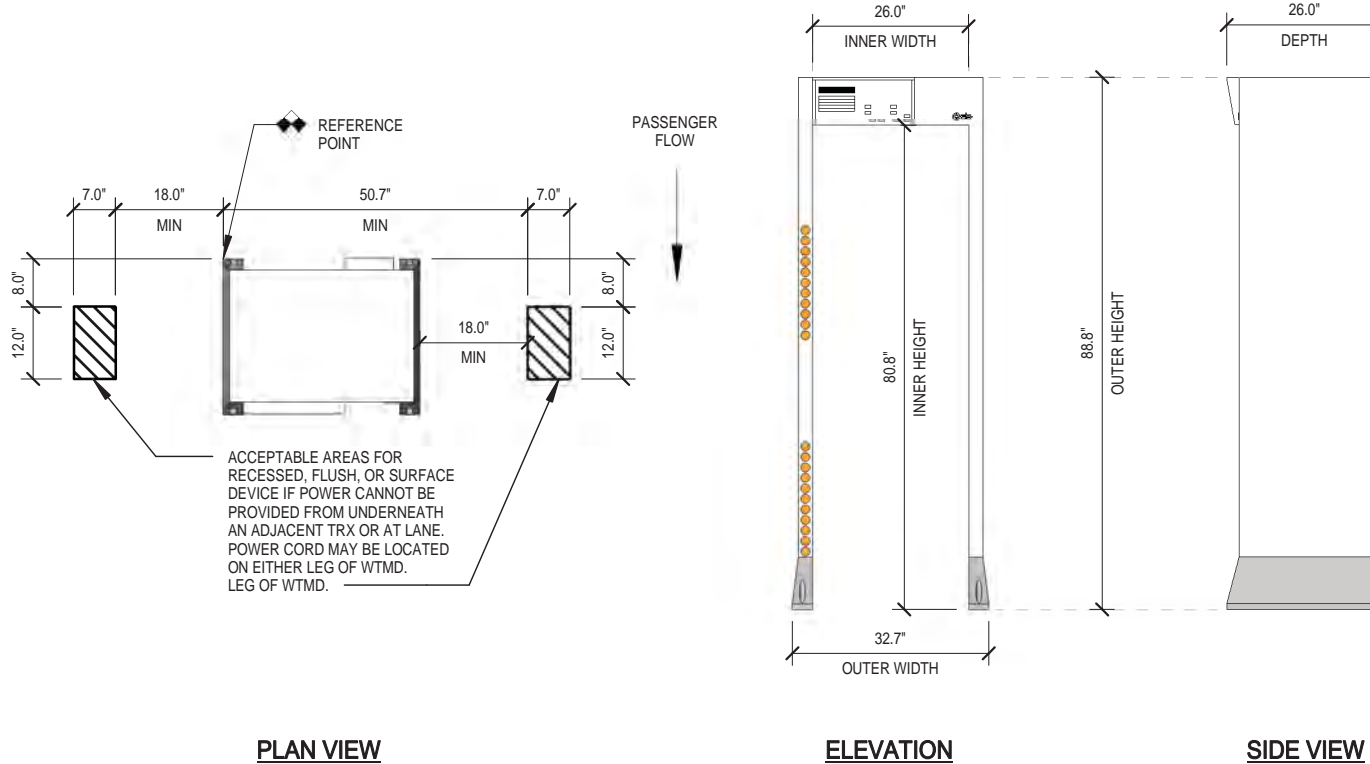

Figure 2-24 WTMD

Equipment	Quantity	Power Requirements	IT Requirements	Additional Information
CEIA 02PN20 Garrett PD6500i Metorex 200HDe	Arrangement Dependent	<ul style="list-style-type: none"> Dedicated circuit for WTMDs ONLY, maximum of 10 per circuit CEIA: 15A, 125V, 40VA/unit Garrett: 15A, 125V, 55VA/unit Metorex: 15A, 125V, 45VA/unit 2-Pole, 3-Wire Grounding NEMA L5-15R Simplex Receptacle (twistlock) 13' power cord from the WTMD to the receptacle 24" minimum clearance from leg to nearest electrical conduit or device Poke-through and pedestal receptacles for the WTMD can be located in the TRX or AT device under the lane as long as it is a separate circuit. 	<ul style="list-style-type: none"> Data Drops = 2 Cat5e / Cat6 cable The cable length from the termination point in the IT cabinet to the data outlet in the work area shall not exceed 295'. 	<ul style="list-style-type: none"> Weight: <ul style="list-style-type: none"> » 200 lbs. CEIA unit provided with a separate transformer/rectifier adjacent to the power cord. Provide redundant power and data beneath adjacent X-RAY.



2.7 ADVANCED IMAGING TECHNOLOGY (AIT)

The Advanced Imaging Technology (AIT) provides an additional element of passenger screening by being able to detect a broad spectrum of materials concealed under a passenger's clothing. The two manufacturers deployed today are shown in **Figure 2-25**. The most common unit is the L3 ProVision portal which uses millimeter wave imaging technology similar to the type of waves a cell phone emits to generate clear views of the items in question. The other AIT is the Rapiscan Secure 1000 which uses backscatter technology to produce the passenger image. Refer to **Figure 2-26** and **Figure 2-27** for the plan views and power/data requirements of both manufacturers. Standard layouts with the L3 ProVision AIT are reflected in Section 3. The minimum possible distance between the WTMD and AIT should be maintained for each checkpoint. Decreased spacing between the equipment enhances lane security by reducing the opportunity for contraband exchanges (via "handoff" of prohibited items) between yet-to-be screened AIT passengers and screened WTMD passengers as they move parallel to one another through the lane. Travel distance between the AIT and the WTMD should be minimized (5'-8") while preserving maintenance clearance.

It is best to provide power for the AIT and corresponding UPS from under an adjacent AT lane. The UPS should be located so that it is not a trip hazard to passengers and the AIT operator at the Touch Control Operator Panel (TCOP). When a barrier is located between the L3 AIT control leg or either tower of the Rapiscan AIT and the AT, the AIT power cord can extend to the receptacle under the infeed or outfeed of the AT along the barrier in appropriate surface mounted raceway. The

power cord for the Rapiscan AIT is located on the master tower, but it is acceptable for the AIT power cord to travel under the AIT mat to the Rapiscan UPS at the slave tower. The Rapiscan UPS can be powered from a device under the infeed or outfeed of an AT lane adjacent to either the master or slave tower. Like the Rapiscan AIT power cord, the Rapiscan UPS power cord can also travel under the AIT mat if necessary to support the AIT device location. In some cases, an ADA gate or a WTMD is located between the L3 AIT control leg and the AT. Extending the AIT power cord across passenger flow is a safety hazard and is not an option. For the L3 AIT only and when all other options have been exhausted, the unit can be rotated 180 degrees in order to locate the control leg adjacent to a barrier so that the cord can be extended along the barrier in appropriate surface mounted

Figure 2-25 AIT Units

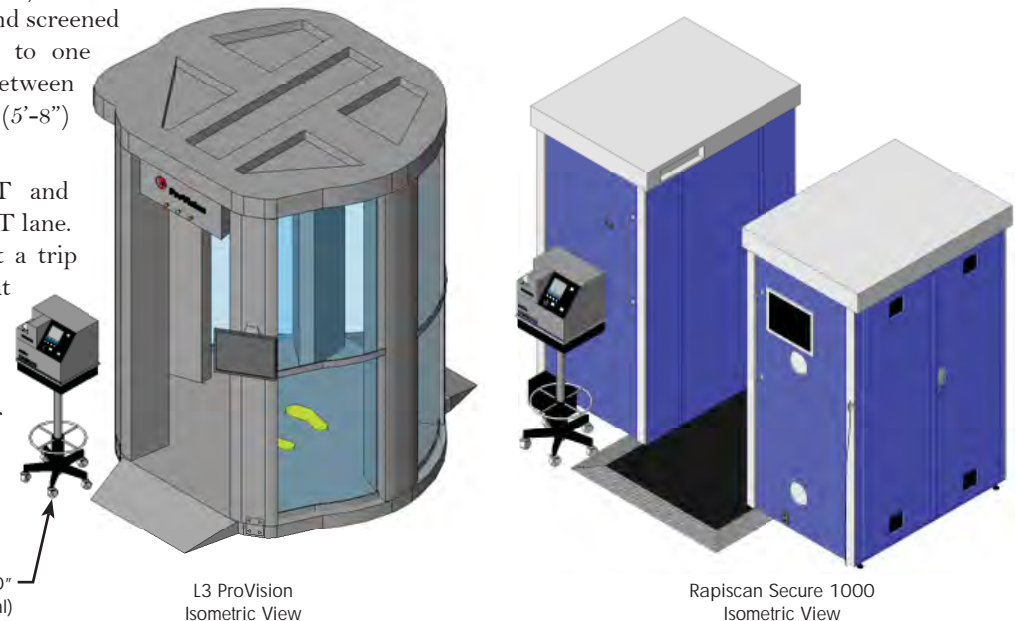

ETD, RE: Section "2.7.1 AIT ETD"
on page 40 (Typical)

L3 ProVision
Isometric View

Rapiscan Secure 1000
Isometric View

raceway. When there is passenger flow on both sides of the AIT, such as an ADA gate and a WTMD, a full height ceiling-supported power pole should be provided. If a full height ceiling-supported power pole is not acceptable or feasible, a 36" floor-supported power pole should be provided. The Wiremold Vista column is recommended. Designers should review and understand the L3 AIT cord lengths to avoid unnecessarily rotating the AIT. Designers are reminded to consult applicable codes within their region of the country to determine the applicability and countermeasures to address seismic events for both brands. Brand manufacturers have brackets available for purchase.

2.7.1 AIT ETD

Portable Explosive Trace Detection (ETD) units on a movable stand can be located at the exit of the AIT to perform additional screening when there are excess ETD units on site. TSA HQ OSC will not procure additional ETD units for this location. This can be on either side of the AIT exit depending on where the power/data is located. The ETD should be fed from the same device feeding the AIT. Designers are advised to provide power and data for the ETD when developing construction drawings to provide maximum installation flexibility for the optional ETD. Ideally, this ETD should not be located at the TCOP or scanning operator (SO) monitor so that the TSO doesn't have to review images and perform ETD screening in the same small area. Unfortunately, this is not always possible. Colocating the AIT and ETD is optional and is up to local discretion. A 36" space should be provided for the operator when the ETD and AIT are colocated. ETD units are discussed further in Section 2.11.1.

2.7.2 Slope Tolerance

An AIT can be installed on an inclining or a declining floor within the maximum manufacturer recommended angle. These tolerances

pertain to the technical functionality of the equipment and do not take into account building codes or ADA accessibility. For ADA passengers, the slope cannot exceed two percent perpendicular to the direction of travel.

The L3 ProVision system can be operated as follows.

- If the floor slope is parallel to passenger travel, the comfortable maximum floor slope is 1:16.
- If the floor slope is perpendicular to passenger travel, the L3 AIT cannot be installed unless the unit can be rotated parallel to the slope. This may be possible at checkpoints with unique shapes.

Depending upon the slope of the surface the system is installed on, the inner floor of the ProVision system will also be at an angle. At the aforementioned maximum 1:16 slope, the internal floor of the L3 AIT would have a 1:20 slope after adjusting the downhill leveling screws to their maximum extension. In the normal scanning position, this is equivalent to standing with one foot elevated approximately 1" relative to the other and is not normally noticeable.

The Rapiscan Secure 1000 Single Pose system can be operated as follows.

- If the floor slope is parallel to passenger travel, the comfortable maximum floor slope is 1:6.3.
- If the floor slope is perpendicular to passenger travel, the comfortable maximum floor slope is 1:8.3.

At the upper maximum slopes, compensatory steps such as leveling the machine's feet and/or adjusting the floor mat position may be necessary.

Figure 2-26 AIT - L3

Equipment	Quantity	Power Requirements	IT Requirements	Additional Information
L3 ProVision	Arrangement Dependent	<ul style="list-style-type: none"> Dedicated 20A, 125V, 1920VA/unit 2-Pole, 3-Wire Grounding NEMA 5-20R Simplex Receptacle Freestanding Tripp Lite UPS provided by vendor 25' power cord from the AIT to the UPS (originates in control leg) 10' power cord from the UPS to the receptacle Refer to Figure 2-34 for ETD power and data requirements. Refer to Section 2.5.1 equipment plan views for detailed outlet locations when power is fed from the adjacent AT lane. 	<ul style="list-style-type: none"> Data Drops = 2 The cable length from the termination point in the IT cabinet to the data outlet in the work area shall not exceed 295'. 	<ul style="list-style-type: none"> An ETD can be co-located with the AIT for additional pax screening if available on site. The ETD can be located at or on the same side as the control leg. Height/Ceiling clearance requirement: <ul style="list-style-type: none"> » 9'-0" / 9'-3" Weight: <ul style="list-style-type: none"> » 1,800 lbs. Can be installed on a floor with a 1:16 floor slope parallel to passenger travel only. The Touch Control Operator Panel (TCOP) may not be mounted on control leg. Power cord can be positioned up and over unit to avoid rotation. The 16'-0" shipped USB cable can be substituted for a 25'-0" cable in the field if necessary.

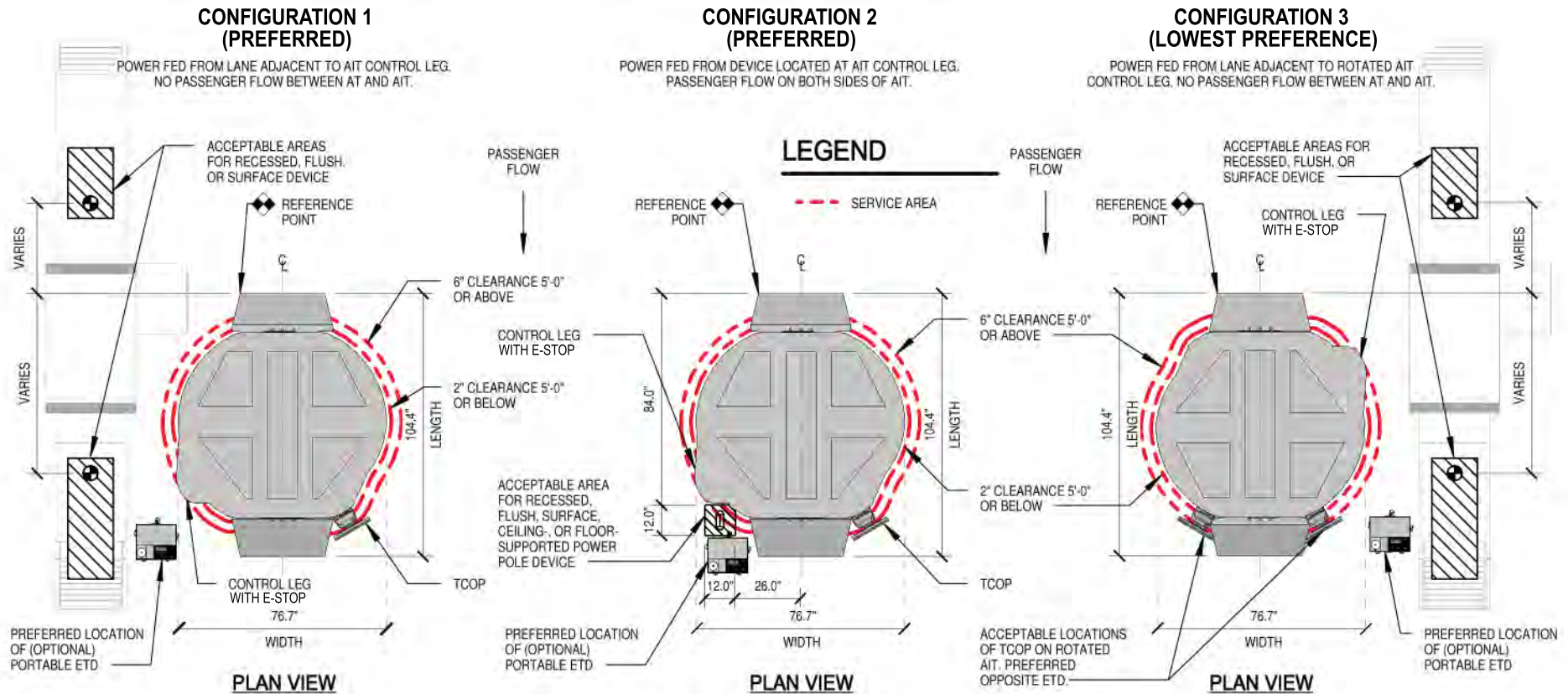
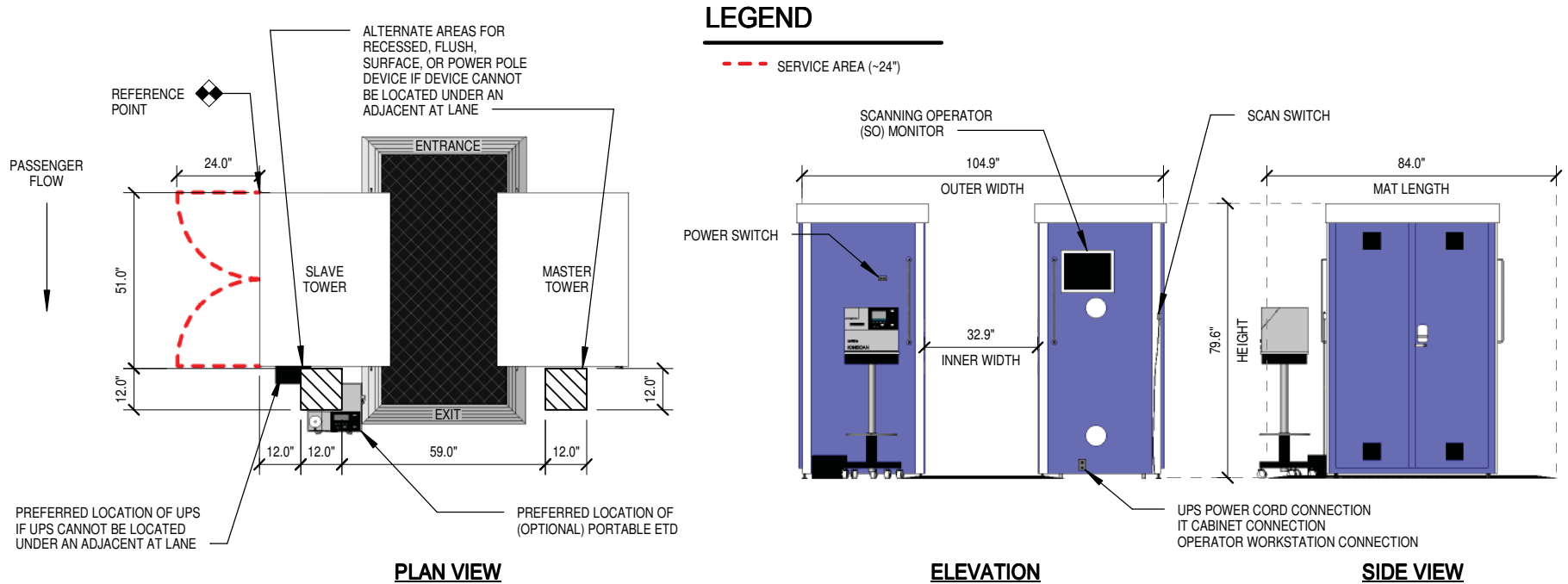

Figure 2-27 AIT - Rapiscan

Equipment	Quantity	Power Requirements	IT Requirements	Additional Information
Rapiscan Secure 1000	Arrangement Dependent	<ul style="list-style-type: none"> Dedicated 20A, 125V, 1200 VA/unit 2-Pole, 3-Wire Grounding NEMA 5-20R Simplex Receptacle Freestanding UPS provided by vendor 15' power cord from the AIT to the UPS 6' power cord from the UPS to the receptacle Refer to Figure 2-34 for ETD power and data requirements. Refer to Section 2.5.1 equipment plan views for detailed outlet locations when power is fed from the adjacent AT lane. The AIT and UPS cords can travel under the AIT mat to the receptacle, if necessary. 	<ul style="list-style-type: none"> Data Drops = 2 20' vendor-provided Cat5e cable from the AIT to the AIT operator workstation. For distances greater than 20' and less than 295', the installing contractor shall provide patch cables from the AIT to the data outlet at the AIT device and from the AIT operator workstation to the data outlet at the workstation. The installing contractor should also run data cable from the AIT device to the workstation device. When the AIT workstation is located more than 295' from the AIT, an independent network solution must be provided. Copper and Cat6 cables shall be routed from the AIT to a rack-mounted, gigabit speed, multi-port copper and fiber optic switch located in the IT cabinet. 	<ul style="list-style-type: none"> An ETD can be co-located at the AIT for additional passenger screening if available on site. ETD can be located at master or slave tower. Ceiling clearance requirement: <ul style="list-style-type: none"> » 7'-8" Weight: <ul style="list-style-type: none"> » 2,194 lbs. Can be installed on a floor with a 1:6.3 floor slope parallel to the direction of passenger travel and a 1:8.3 floor slope perpendicular to passenger travel only if acceptable to ADA requirements.



2.8 BARRIERS

In order to prevent passengers and items from passing into the sterile area from the non-sterile area without being screened, barriers must be installed to close all gaps exceeding 12" across the front width or façade of the checkpoint. The recommended gap width is 9". All barriers must be flush with the floor and be at least 48" above finished floor (AFF). Barriers must be rigid enough to prevent vibrations that could interfere with the WTMD and must be self-supporting to reduce any potential hazard to passengers and personnel at the checkpoint. Standard TSA barriers are made of transparent material and come in 12", 24", 36", and 48" widths. See **Figure 2-28**.

Figure 2-28 Barriers

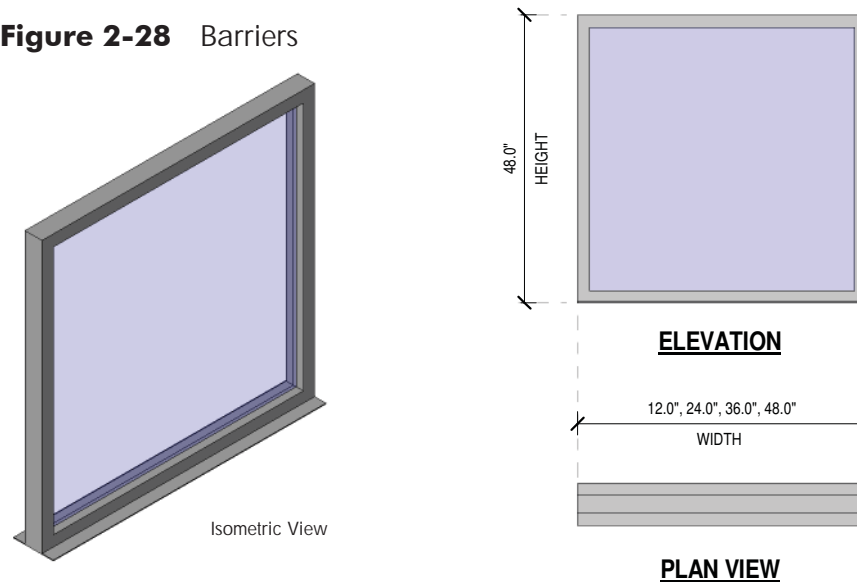

2.9 ADA/ACCESS GATE

The ADA gate on the passenger side is part of the line that separates the non-sterile area from the sterile area. The ADA gate allows passengers that cannot otherwise traverse the WTMD or AIT to reach the sterile area. The ADA gate is typically used by wheelchair passengers, passengers requiring special assistance, or passengers with pacemakers. These passengers are brought from the queue through the ADA gate and taken immediately to an area for secondary screening. TSA prefers an ADA gate at every 1- or 2-lane set, but sometimes this is not possible. At a minimum, there should be at least one ADA gate for every six lanes. Using an adjacent checkpoint exit lane is not acceptable for bringing ADA passengers into the sterile area of the checkpoint.

The access gate on the operator side is also part of the line that separates the non-sterile area from the sterile area. However, it is used only by TSA staff to access the sterile side and return bins from the composure/extension rollers to the divest tables. It gives TSA personnel a travel path that is free and clear of passengers. The access gate requirement is less stringent than the ADA gate. It should be provided whenever there is space available. When space is unavailable, a 2'-0" or 3'-0" barrier should be used. TSA personnel can still access the sterile side via the passenger path of travel.

The ADA/access gate is approximately 44" wide by 48" tall with a 36" swing gate made of non-metallic, transparent material as shown in **Figure 2-29**. The swing direction of the ADA/access gate should always open towards the sterile side of the checkpoint. The latch side should conform to local code by providing enough space to open the gate around adjacent equipment.

There are many types of ADA/Access gates on site. Some have a specific RH or LH swing and some have a swing that can be configured in the field. The floor support for the gate may also vary. It is important to field verify the type of gate so that any new designs can take the functionality into account.

Figure 2-29 ADA/ Access Gate

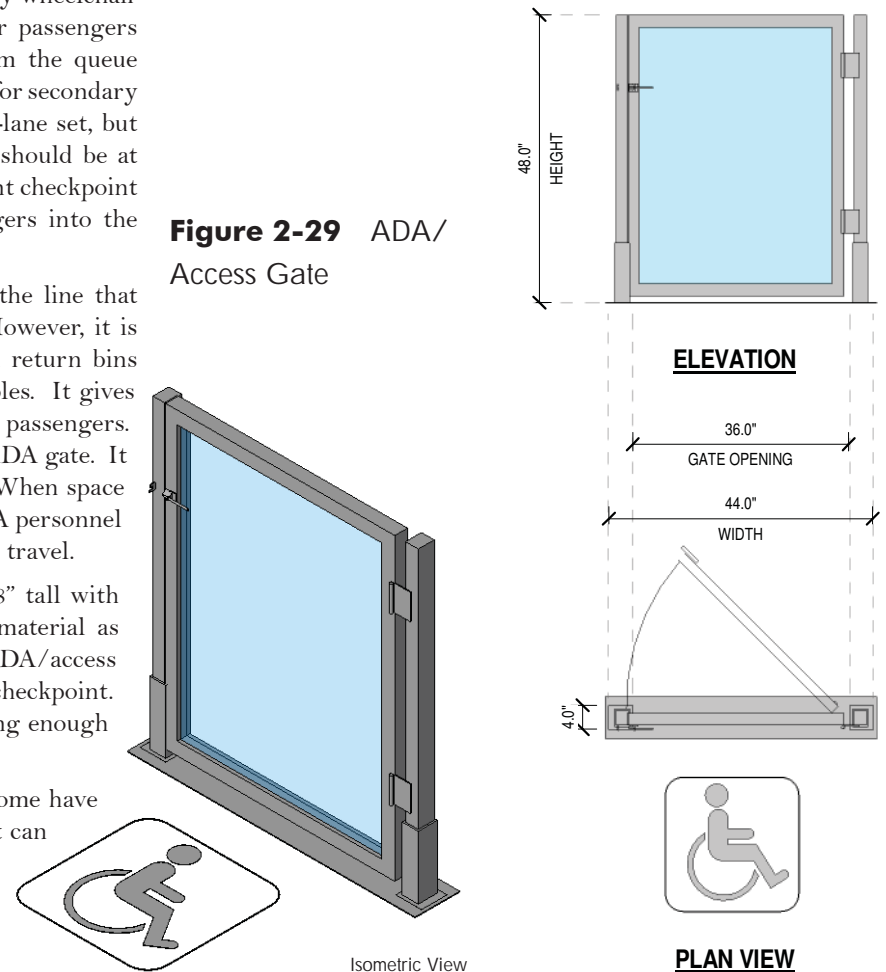

2.10 PASSENGER CONTAINMENT, INSPECTION & RESOLUTION

Passenger containment and inspection can occur at the screening lanes, at the secondary screening area, or in a private room at or near the checkpoint. When passenger containment or inspection is located at the screening lanes, it must be located approximately 4'-0" to 5'-0" from the WTMD so that the WTMD operator can protect the throat of the containment or inspection entrance in order to prevent breaches. Stanchions can be used for passenger containment or inspection at the screening lanes but it is preferred to use 6'-0" high glass panels in order to separate alarmed passengers from cleared passengers. **Figure 2-30** represents the common KI Wall glass kits used for passenger containment and inspection. These kits can be anchored to the floor, secured overhead by a bridge kit, or they can be "freestanding". The manufacturer should always be consulted when variations are needed.

Figure 2-30 Passenger Containment and Inspection Kits

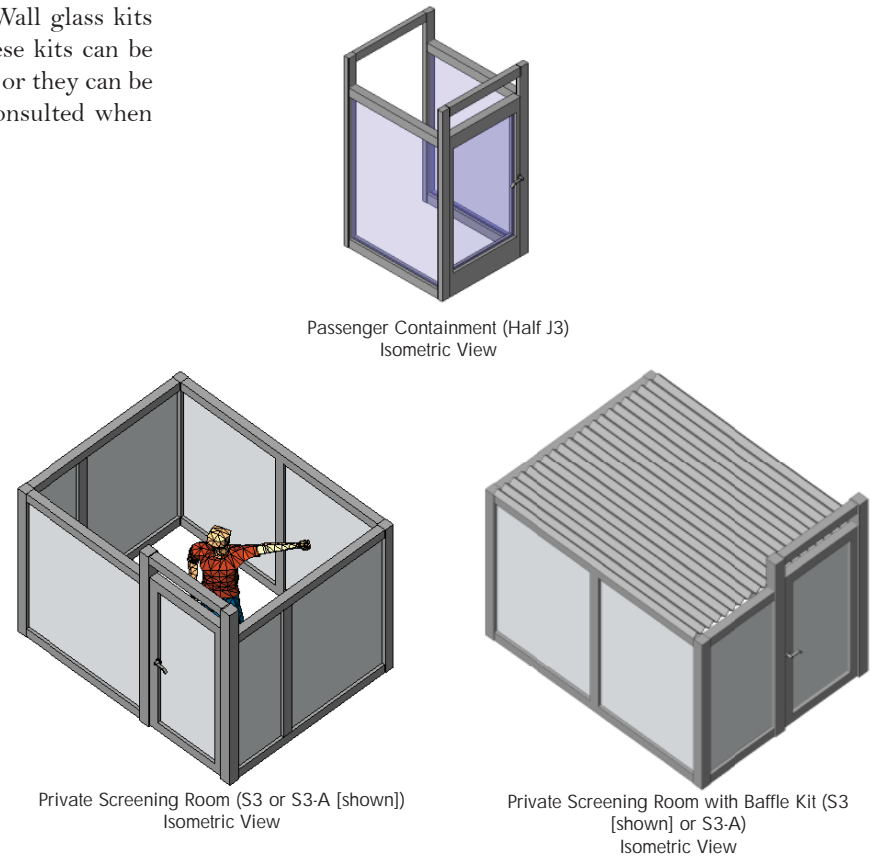

2.10.1 Passenger Containment (Half J3)

Passenger containment at the screening lanes can be achieved by using a half J3 glass kit. **Figure 2-31** reflects the dimensions of the half J3 glass kit. The half J3 kit is referred to as a holding station because it can “hold” up to three alarmed passengers simultaneously until a TSO becomes available to escort the passenger to the secondary screening area. The half J3 kit is constructed of clear, modular 4’-0” wide by 6’-0” high glass panels with a 3’-0” door that can be latched on the outside by TSA.

A passenger diverted to the holding station has alarmed the WTMD, or the passenger was unable to traverse the WTMD because he/she is in a wheelchair or has a pacemaker. The holding station must

be positioned near the WTMD so that passengers can be diverted directly into it without obstructing the path of passengers who were successfully cleared through the WTMD. The holding station must also prevent the passage of prohibited items from passengers in the holding station to cleared passengers in the sterile area. Checkpoints that are narrow and deep are ideal for holding stations.

Figure 2-31 Half J3

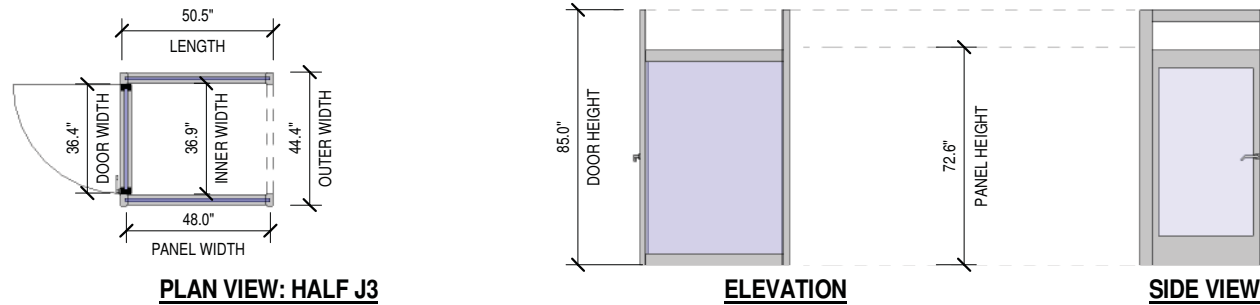

2.10.2 Private Screening Room (PSR)

The PSR, shown in **Figure 2-32**, is approximately 6'-0" by 8'-0" with 8'-0" high glass panels and a 3'-0" door on either the short wall (S3) or the long wall (S3-A). The location of the PSR should be centralized at the checkpoint when possible in order to minimize the walking distance for passengers and TSOs without causing congestion or impeding TSA and/or passenger flow. One PSR per eight lanes is required. The room must be available to accommodate passengers who request pat downs out of the public area. The room needs to be able to accommodate one passenger, including those with disabilities, up to two TSOs, a passenger inspection chair and mat, and a bag search table. In some cases, an escort or interpreter may need to be present. The finish of the glass panels is opaque so that privacy is maintained. If a checkpoint does not have the height clearance to support the 8'-0" tall kit, then a 6'-0" tall kit can be used. It is approximately 6'-0" by 8'-0" with 6'-0" high glass panels and a 3'-0" door on either the short wall (T3) or the long wall (T3-A). Glass kits need to have sufficient clearance from the ceiling so as not to affect HVAC and/or lighting. If the PSR can be viewed from a concourse above or if cameras are located above or aimed at the room, then a baffle kit consisting of slats should be installed to prevent a direct line-of-sight into the room. Baffle kits can only be installed on S3 or S3-A kits. There will be a head clearance issue if installed on a T3 or T3-A. The baffle kit is shown on an S3 glass kit in **Figure 2-30**.

A private screening curtain or an airport-provided room at or near the checkpoint could also be used for private screening functions. Curtains are to be selected and purchased by local TSA with OSC concurrence. Various curtain options can be found at www.cubiclecurtainfactory.com. TSA HQ does not have a contract with this vendor. Other vendors can be pursued by local TSA as long as the PSR requirements are met and OSC approves the solution.

Designers should include power and data for future technology as shown in **Figure 2-32**.

Figure 2-32 Private Screening Room (S3 or S3-A)

Equipment	Quantity	Power Requirements	IT Requirements	Additional Information
Private Screening Room (S3 or S3-A)	1 per 8 lanes	<p>The following requirements occur once inside and once outside the private screening room:</p> <ul style="list-style-type: none"> • Non-dedicated circuit • 20A, 125V, 350VA/unit • 2-Pole, 3-Wire Grounding • NEMA 5-20R Quad or Duplex Receptacle 	<ul style="list-style-type: none"> • Data Drops = 2 • Cat5e / Cat6 cable • The cable length from the termination point in the IT cabinet to the data outlet in the work area shall not exceed 295'. 	<ul style="list-style-type: none"> • S3 and S3-A kits have 8' high glass panels. • S3 and S3-A kits can have LH or RH door swings. Power/data should be located based on door configuration. The default from KI Wall is a RH door swing. LH door swings must be specified. • S3 and S3-A kits may be installed with optional baffle kits. • The PSR should be centralized at the checkpoint when possible.

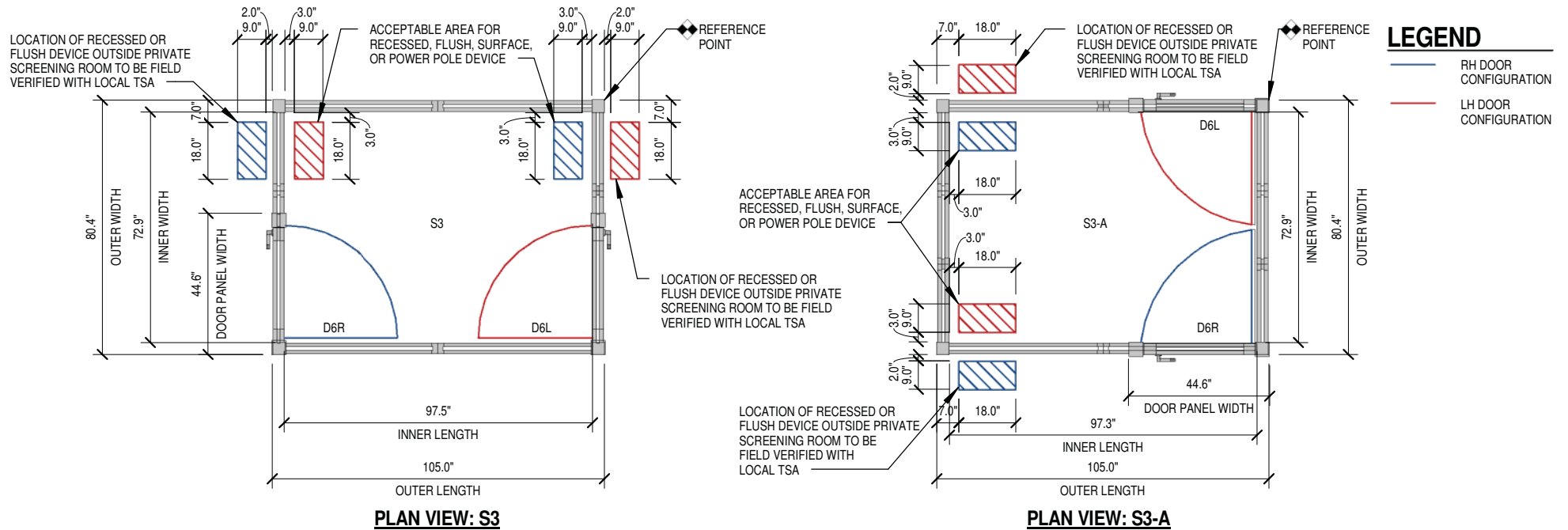

2.11 SECONDARY SCREENING

Secondary screening is additional screening that may be required for passengers and their bags when they alarm primary screening equipment. It is an area that is approximately 3'-0" to 5'-0" from the end of the screening lanes in order to minimize travel time and the distance that TSOs have to carry bags. Secondary screening is typically located in the "dead" operator space on back-to-back lanes or at the end of the lane for odd numbered lanes. This area should be clear of exiting passengers. The secondary screening area typically consists of Explosive Trace Detection (ETD) unit, a Bottle Liquid Scanner (BLS), an AVS (previously discussed in Section 2.5.1), a Mobile Cabinet, a search table and a passenger search chair and mat. Refer to **Figure 2-33**.

2.11.1 Explosive Trace Detection (ETD)

ETD units are used to swab carry-on bags that have alarmed at the TRX, AT or AutoEDS. These units should be contained within a mobile cabinet but can sometimes be found sitting directly on a search table.

The ETD machines require operational, testing and maintenance supplies located within arms reach of the working area. If a mobile cabinet is not used, then alternative storage is required for these items. ETD manufacturers and their specifications are listed in **Figure 2-34**. The ETD units should be co-located with one search table for a single lane and two search tables for back-to-back lanes. These same ETDs may also be located at the exit of AIT units as a method of secondary screening for passengers who alarm the AIT. These ETDs are referred to as portable ETDs because they are on a mobile cart. Refer to Section 2.7.

ETDs are extremely sensitive to environmental conditions such as temperature, humidity, and air quality. ETDs should be clear of fumes and exhaust to prevent malfunctioning. The ETD units also have a high heat output and should be vented if placed in a non-standard TSA storage device.

2.11.2 Bottle Liquid Scanner (BLS)

These scanners aid the TSA in identifying explosive, flammable, or hazardous substances that have been concealed in a benign container. The containers can be sealed and do not have to be open to perform the analysis. Through the use of Raman spectroscopy (laser) and electromagnetic technology, these units are able to quickly analyze and identify the chemical compositions of a wide variety of unknown solids and liquids, including explosives that are currently on the classified threat list. Manufacturers and the procurement specifications are listed in **Figure 2-34** with the ETDs.

Figure 2-33 Secondary Screening Area

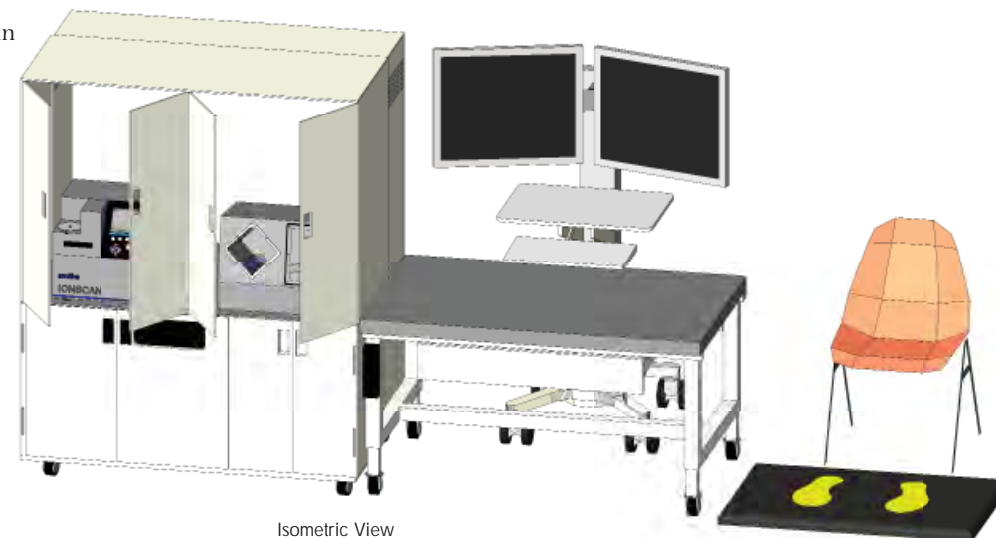
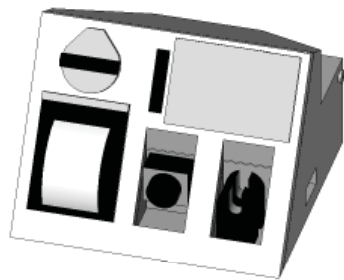

Figure 2-34 ETD & BLS Units

Equipment	Quantity	Power Requirements	IT Requirements	Additional Information
GE IonTrack Itemiser ETD GE IonTrack Itemiser ³ ETD Smiths IonScan 400B ETD Smiths IonScan 500DT ETD	<ul style="list-style-type: none"> Per Cabinet: <ul style="list-style-type: none"> » 1 per 2 lanes » 1 per odd lane 1 per AIT if available on site 	<ul style="list-style-type: none"> Non-dedicated, shared with the AVS and BLS circuit at the same search area 2-Pole, 3-Wire Grounding NEMA 5-20R Duplex Receptacle GE: <ul style="list-style-type: none"> » 20A, 125V, 120VA/unit » 6'-6" power cord from the ETD to the receptacle Smiths: <ul style="list-style-type: none"> » 20A, 125V, 350VA/unit » 7'-8" power cord from the ETD to the receptacle 	<ul style="list-style-type: none"> Data Drops = 2 Cat5e / Cat6 cable The cable length from the termination point in the IT cabinet to the data outlet in the work area shall not exceed 295'. 	<ul style="list-style-type: none"> ETDs are located with the AVS/BLS and at the exit of the AIT if available. Refer to AVS and AIT equipment plan views for outlet locations.
CEIA EMA-MS BLS Smiths Responder RCI BLS	<ul style="list-style-type: none"> Per Cabinet: <ul style="list-style-type: none"> » 1 per 2 lanes » 1 per odd lane 	<ul style="list-style-type: none"> Non-dedicated, shared with the AVS and ETD circuit at the same search area 2-Pole, 3-Wire Grounding NEMA 5-20R Duplex Receptacle CEIA: <ul style="list-style-type: none"> » 20A, 125V, 61.2VA/unit » 6'-8" power cord from BLS to receptacle Smiths: <ul style="list-style-type: none"> » 20A, 125V, 216VA/unit » 6'-6" power cord from the BLS to the AC/DC converter » 6'-6" power cord from the AC/DC converter to the receptacle » The AC/DC converter should be secured in the ETD-BLS mobile cabinet so as to not strain the power adapter connection to the ResponderR unit. 	<ul style="list-style-type: none"> Data Drops = 2 Cat5e / Cat6 cable The cable length from the termination point in the IT cabinet to the data outlet in the work area shall not exceed 295'. 	<ul style="list-style-type: none"> BLS is located with the AVS/ETD. Refer to AVS equipment plan views for outlet locations.

ETD



GE IonTrack Itemiser
Isometric View



GE IonTrack Itemiser³
Isometric View



Smiths IonScan 400B
Isometric View



Smiths IonScan 500DT
Isometric View

BLS

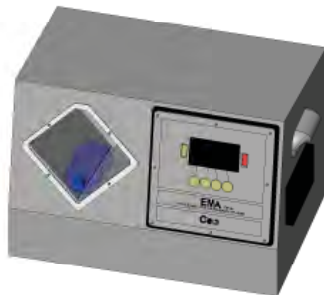

CEIA EMA-MS
Isometric View



Smiths Responder RCI
Isometric View

2.11.3 Mobile Cabinets

Mobile Security Cabinets provide a secure and vented storage area for secondary screening equipment. There are two mobile cabinets that should be used for secondary screening. The ETD Mobile Cabinet is common in the field today. It encloses the ETD and operational, testing, and maintenance supplies. The ETD-BLS Mobile Cabinet will enclose the ETD and BLS, as well as operational, testing, and maintenance supplies. This cabinet has not yet been manufactured. **Figure 2-35** shows the dimensions of both cabinets. The cabinets have wheels for easy relocation, but the wheels should be locked when the ETD or BLS is in operation. Power/data receptacles for the secondary screening area should not be located under the mobile cabinets as the bottom of the cabinet is low to the floor and would not provide enough clearance for devices or plugs.

Figure 2-35 ETD-BLS & ETD Mobile Cabinets

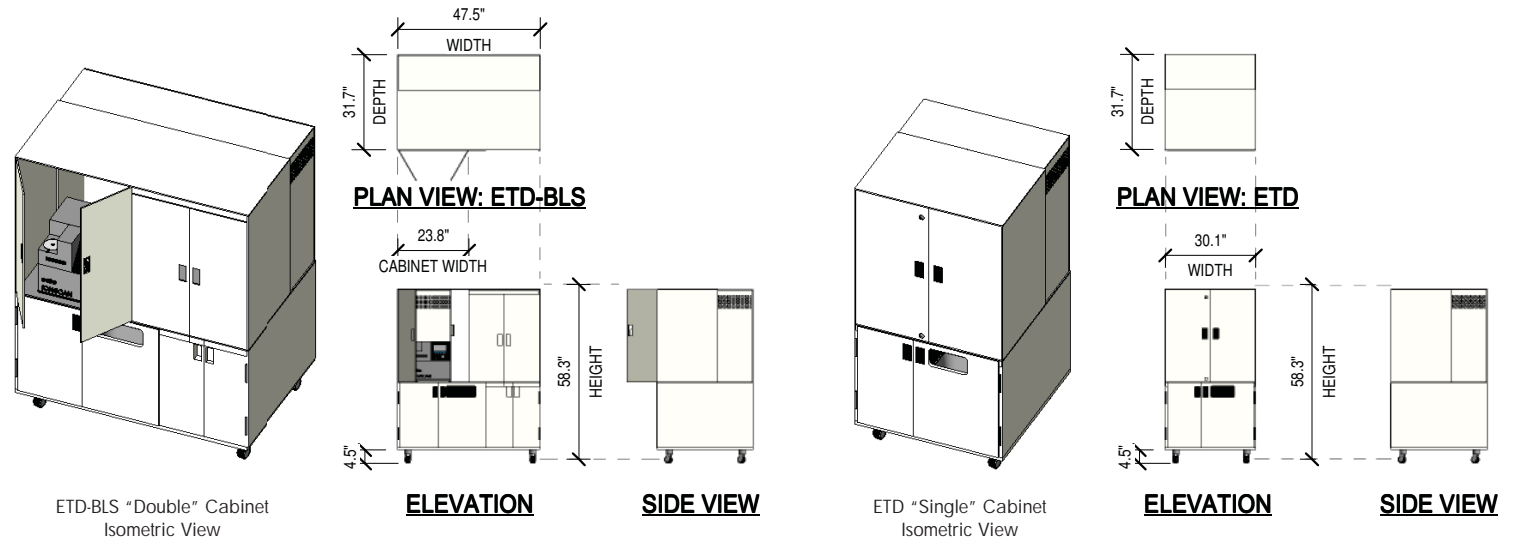

2.11.4 Bag Search Table

Bag search tables are used for target bag searches, ETD swabbing, and BLS testing. The stainless steel surface allows TSA to provide a clean, contaminant-free surface. See **Figure 2-36**. The bag search tables have wheels for easy relocation, but the wheels should be locked during ETD, BLS, and bag search functions. The back and side panels offer privacy during bag searches but are often removed when the bag search table is located with an AVS.

Figure 2-36 Bag Search Table

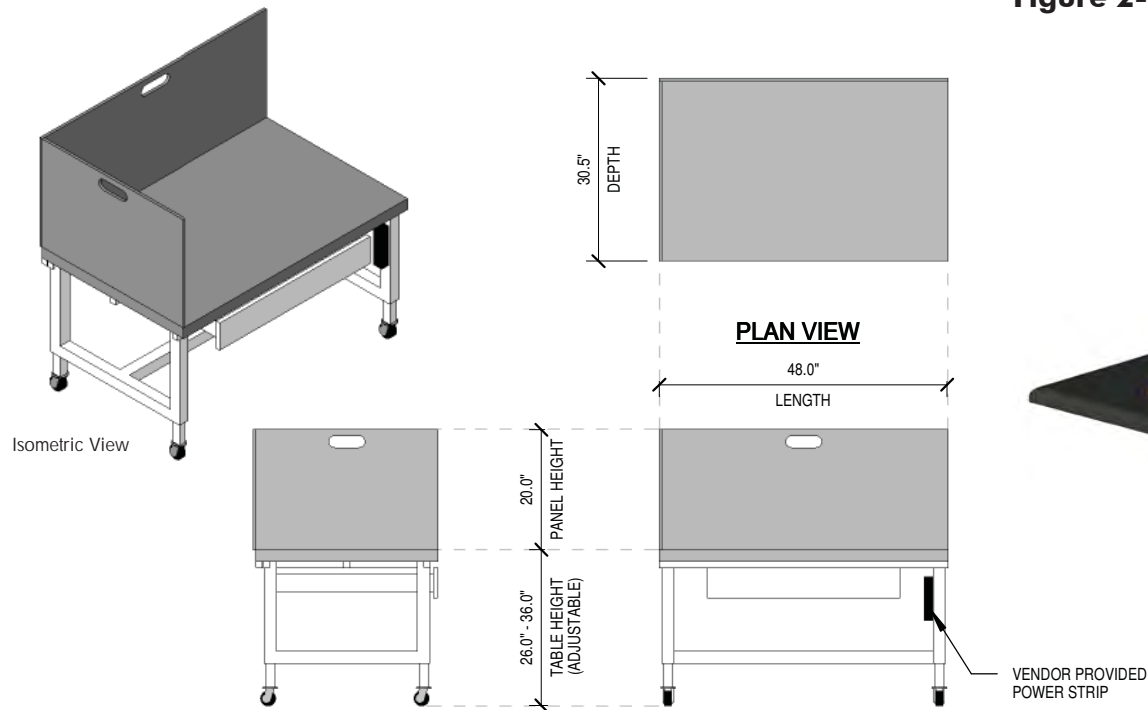

2.11.5 Passenger Search Position

When a passenger's body or bag alarms during primary screening, they are escorted to a passenger search position within the secondary screening area unless there is an N3 passenger inspection kit (Refer to Section 2.10) at the lane or if the passenger requests private screening. Passenger inspection at the secondary screening area consists of a 6'-0" by 6'-0" area that includes a passenger inspection chair and mat. Refer to **Figure 2-37**. This area needs to be wide enough for a TSO to screen a standing or wheelchair passenger and for the passenger to be able to maintain eye contact with his/her belongings and family members.

Figure 2-37 Passenger Search Position



2.12 COMPOSURE BENCH

Egress seating at the checkpoint is used for passengers to sit down and compose themselves with their personal belongings after completing the screening process. The screening experience is greatly improved if passengers can sit down to put their shoes and jackets on. TSA provides composure benches approximately 6'-0" from J3 or N3 kits or 14'-0" from an AIT depending on the equipment arrangement. This area is typically out of the main passenger flow. **Figure 2-38** shows the dimensions of the TSA-provided composure bench. The airport may provide additional benches or seating for this same purpose near the exit of the checkpoint, but they may vary in size.

Figure 2-38 Composure Bench

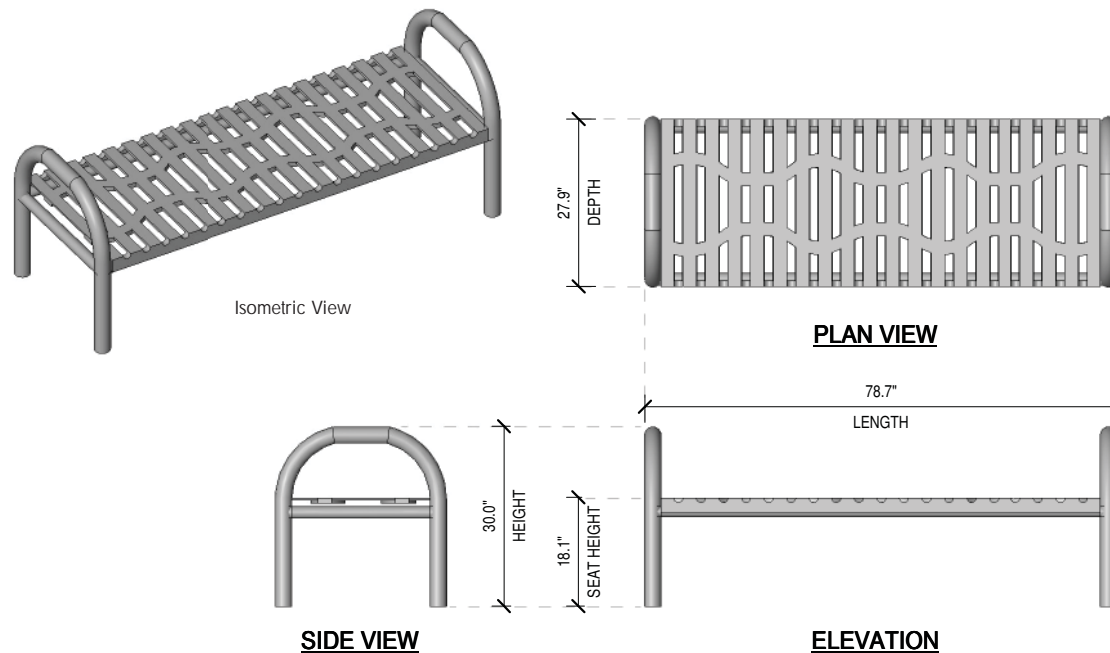

2.13 SUPERVISORY TRANSPORTATION SECURITY OFFICER (STSO) PODIUM

The Supervisory Transportation Security Officer (STSO) should be positioned at a podium like the one shown in **Figure 2-39** near the checkpoint exit. Dimensions of the podium as well as the power/data requirements are illustrated in **Figure 2-40**. The STSO should be able to perform administrative duties while viewing and supervising the entire screening operation. The location should have an unobstructed view of the checkpoint.

Figure 2-39 STSO Podium

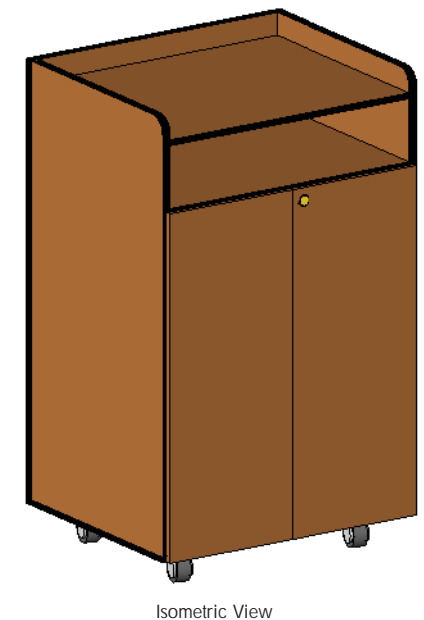
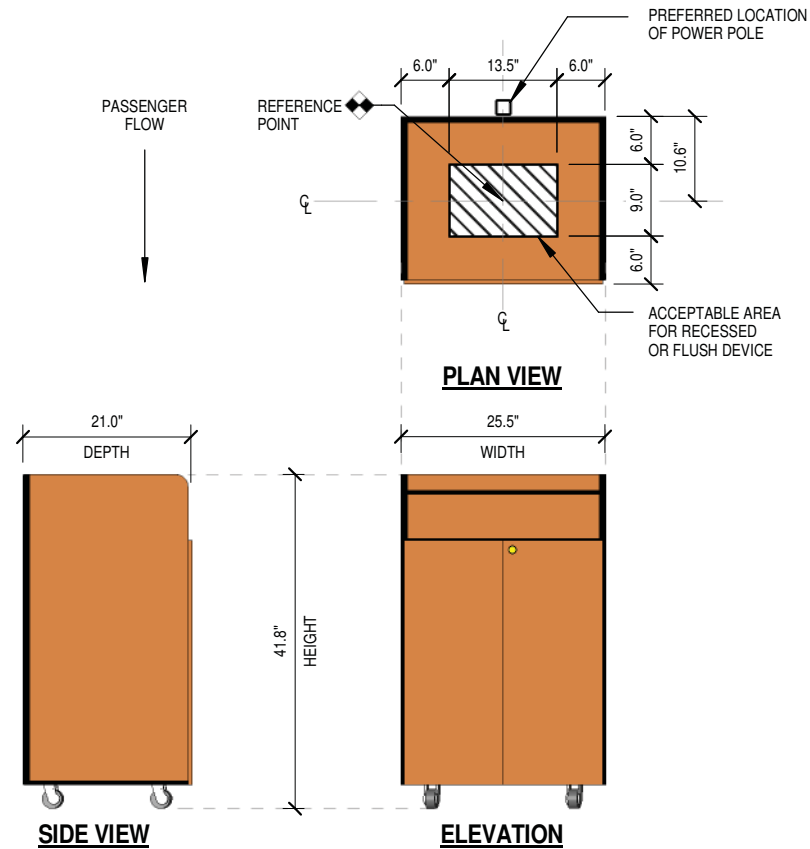

Figure 2-40 STSO Podium

Equipment	Quantity	Power Requirements	IT Requirements	Additional Information
STSO Podium	1 per 4 lanes	<ul style="list-style-type: none"> • Non-dedicated • 20A, 125V, 180VA/podium • 2-Pole, 3-Wire Grounding • NEMA 5-20R Quad or Duplex Receptacle • 6' to 10' power cord from the TSA laptop to the receptacle 	<ul style="list-style-type: none"> • Data Drops = 2 • Cat5e / Cat6 cable • The cable length from the termination point in the IT cabinet to the data outlet in the work area shall not exceed 295'. 	



2.14 SSCP BOUNDARIES

There is no set boundary of an SSCP. Boundaries of a SSCP will vary by airport, based on SSCP configuration, and TSA requirements for a particular checkpoint. Typically, the SSCP length starts at the TDC podium(s), extends through the checkpoint elements discussed in this section, and ends at the checkpoint exit, which could be at or near the egress seating area or STSO podium. The SSCP width is the wall-to-wall width of the checkpoint, including all the screening lanes and a co-located exit lane. All walls adjacent to the non-sterile side need to be at least 8'-0" high to prevent the passage of prohibited items from the non-sterile area to the sterile area. In the future, new technology may extend the boundaries of the SSCP as we know it today to include additional equipment and functions within the checkpoint or equipment and functions located remotely within the airport.

2.15 EXIT LANE

An exit lane can be co-located with a checkpoint, or it can be located independent of the checkpoint. This lane should be easily identifiable without adversely affecting security. It should also be adequately sized for deplaning passengers exiting the concourse. All building code egress path requirements must be met.

An 8'-0" or full height wall is required to separate the checkpoint from the exit lane or separate the sterile area from the non-sterile area. This height impairs the ability for uncleared passengers to pass prohibited items to a cleared passenger. This requirement should be coordinated with the airport authority when a new checkpoint is being discussed or an existing checkpoint is being reconfigured and the exit lane needs to be modified.

An exit lane is typically equipped with a table, chair, and podium for a person to monitor the area and deter those attempting to bypass the SSCP from the non-sterile area. The monitor should be located so that traffic attempting to enter the exit lane from the wrong direction

can be intercepted. For long exit lanes, there is typically a monitor at both ends. TSA may share operational responsibility of the exit lane with other parties such as the airport operator or an airline carrier. These parties may also contribute to the design of the area to ensure that unauthorized entry does not occur.

Unique solutions have been deployed to secure exit lanes such as adding revolving doors or turnstiles, CCTV systems, and/or breach alarms. These solutions must allow sufficient space to accommodate the equipment as well as passengers with baggage and/or passengers with disabilities. Another simple solution is to provide clear glass panels when an exit lane is adjacent to the checkpoint. This often deters breaches since the exit lane would be highly visible by TSA and airport/airline personnel. These elements can also be combined to create an integrated system that utilizes video cameras, video monitors, sensors, and breach alarms concealed within the architectural elements and tied to a centralized system. This would further tighten security around this sensitive area without relying solely on manpower. In new facility planning and design, SSCP exit lanes should be a considerable distance from boarding gates to allow for sufficient time to resolve a breach if one should occur.

This page is intentionally left blank.

3.0 STANDARD SSCP LAYOUTS

With approximately 730 checkpoints in existence today, it is easy to understand how there are various equipment arrangements based on the approved approach at the time of implementation at the checkpoint. Site conditions and local input also impact the look of a checkpoint. TSA intends for each arrangement to meet baseline standards based on the current threat. However, these standards change often due to the development of new technology intended to detect threats yet to be discovered. The following pages illustrate the currently approved arrangements of checkpoint equipment at the time of this guide's printing that will be common across the 450 federalized airports. It is recommended that designers coordinate with TSA when designing layouts.

Checkpoints consist of standard module sets or combinations of standard module sets based on a particular arrangement of a given type and quantity of screening equipment that has been previously tested by TSA. A module set is either one or two lanes. A 1-lane module set will typically have an X-ray (AT1, AT2 with MDR, or AutoEDS), a Walk Through Metal Detector (WTMD) and/or an Advanced Imaging Technology (AIT) unit, passenger containment, and a secondary screening area that includes Explosive Trace Detection (ETD), Bottle Liquid Scanner (BLS), Alternate Viewing Station (AVS) for AT2, and passenger and carry-on bag inspection. A 2-lane module set is the same as a 1-lane module set with the addition of another X-ray (AT1, AT2 with MDR, or AutoEDS) opposite the first X-ray with the other equipment being located between the two lanes. The equipment between the lanes is known as the "infield" equipment. A 2-lane module set or a combination of 2-lane module sets is the best approach for configuring a checkpoint because it efficiently utilizes screening equipment and TSA personnel. However, a 1-lane module set should be used if the peak passenger load only supports 1-lane, the checkpoint has an odd number of lanes, or there is an obstruction, such as a column, electrical closet, or chase that prevents adding a 2-lane module set.

Module sets are sometimes categorized by the quantity of X-rays (AT1, AT2, or AutoEDS) in the module set compared to the quantity of equipment used to screen passengers. For example, a 1-to-1 configuration can be one X-ray per one WTMD or one X-ray per one AIT. A 2-to-1 configuration can be two X-rays per one WTMD or two X-rays per one AIT. A 2-to-2 configuration can be two X-rays per two AITs. This terminology is not used when the infield equipment is a combination of a WTMD and an AIT.

The purpose of this section is to illustrate the approved arrangements and corresponding module set. Refer to the following pages for an overview of the arrangements.

All designs going forward for new checkpoints or reconfigurations of existing checkpoints should be based on the module sets of an arrangement prescribed by TSA HQ in the early stages of planning. A graphic representation of the arrangement is presented in **Figure 3-3**. Note that the secondary screening area is not included with the module sets in order to maximize the scale of the graphics. The Rapiscan AT and L3 AIT were used in the module sets and arrangements, but any manufacturer included in this guide can be applied using the same recommended spacing. Note that some adjustments to the layout may be required to account for different equipment dimensions which can be found in the equipment plan views in Section 2.

The AutoEDS Module Sets are not a part of these figures, but they are depicted in Section 9.7

3.1 TSAPRE✓™

TSAPre✓™ is an expedited screening initiative that is expanding to airports across the country. By the end of 2012, TSAPre✓™ will be in place for eligible participants in 35 airports for 5 airlines.

TSA plans to continue expanding the TSAPre✓™ concept to additional airlines and airports once operationally ready. As passenger segments are added, airports implementing in 2012 and beyond will likely see a need for quick growth in their capacity for screening eligible passengers. Volume-driven expansion will be based on a threshold of 300 passengers per hour per lane with a five minute wait time.

- TSA HQ will not permit any local infrastructure changes for purposes of TSAPre✓™ expansion.
- TSAPre✓™ operations must be conducted using a CEIA WTMD and a Smiths or Rapiscan AT2 X-ray.¹
- Initially, TSAPre✓™ will be implemented in one lane out of a mod-set. If the selected mod-set is WTMD-only, a second WTMD may be required if two lanes of TSAPre✓™ volume is not initially predicted. If the selected mod-set contains an AIT, the mod set will be split into two single lanes with the AIT lane operated without a co-located WTMD for overflow. TSAPre✓™ passengers will use WTMD; 100% AIT screening will be conducted for standard passengers in the mod-set.
- While a WTMD mod-set provides a strong platform for TSAPre✓™ implementation, it should only be considered if existing infrastructure can accommodate a second WTMD (enough width in lane and available electrical/data).
- Holding/corrals are not permitted on AIT mod sets. If a holding

¹ Garrett and Metorex WTMD units have not been assessed for compliance with the TSAPre✓™ security standard. L3 AT2 X-ray units cannot currently support continuous belt operation. The AIT ConOps for TSAPre✓™ has not yet been approved due to the difference in divest requirements to avoid higher touch rates.

corral is required for any reason, it should be designated for standard passengers only when the WTMD mod set is split in two and not to comingle passengers of differing security standards.

- A volume of 300 passengers per hour at peak will require 70 linear feet of queue space, preferably in a snake design. When TSAPre✓™ volume exceeds the single lane capacity and a second lane is required, the queue feeding those TSAPre✓™ lanes will need to expand to meet the incremental demand.
- It is recommended that the TSAPre✓™ queue and any existing Aircraft Operator premium queue be co-located to a single TDC or, at max, two TDCs close enough to provide positive hand off of passengers who enter the queue segment farthest away from the TSAPre✓™ lane.
- Movable 36"x48", 30"x60", and 30"x72" stanchion barriers are required to segregate TSAPre✓™ and standard passengers after TDC.
- Figure 3-2 shows how to flex up a TSAPre✓™ lane within a AIT mod set. The AIT is closed off with a stanchion so the TSAPre✓™ WTMD can process passengers from both x-rays. The expansion concept is the same if a WTMD is on the second lane.
- An original TDC should process solely TSAPre✓™ passengers and a second TDC can process both TSAPre✓™ and standard passenger and direct them to the appropriate lane.

Figure 3-1 AIT Non-Peak Flow

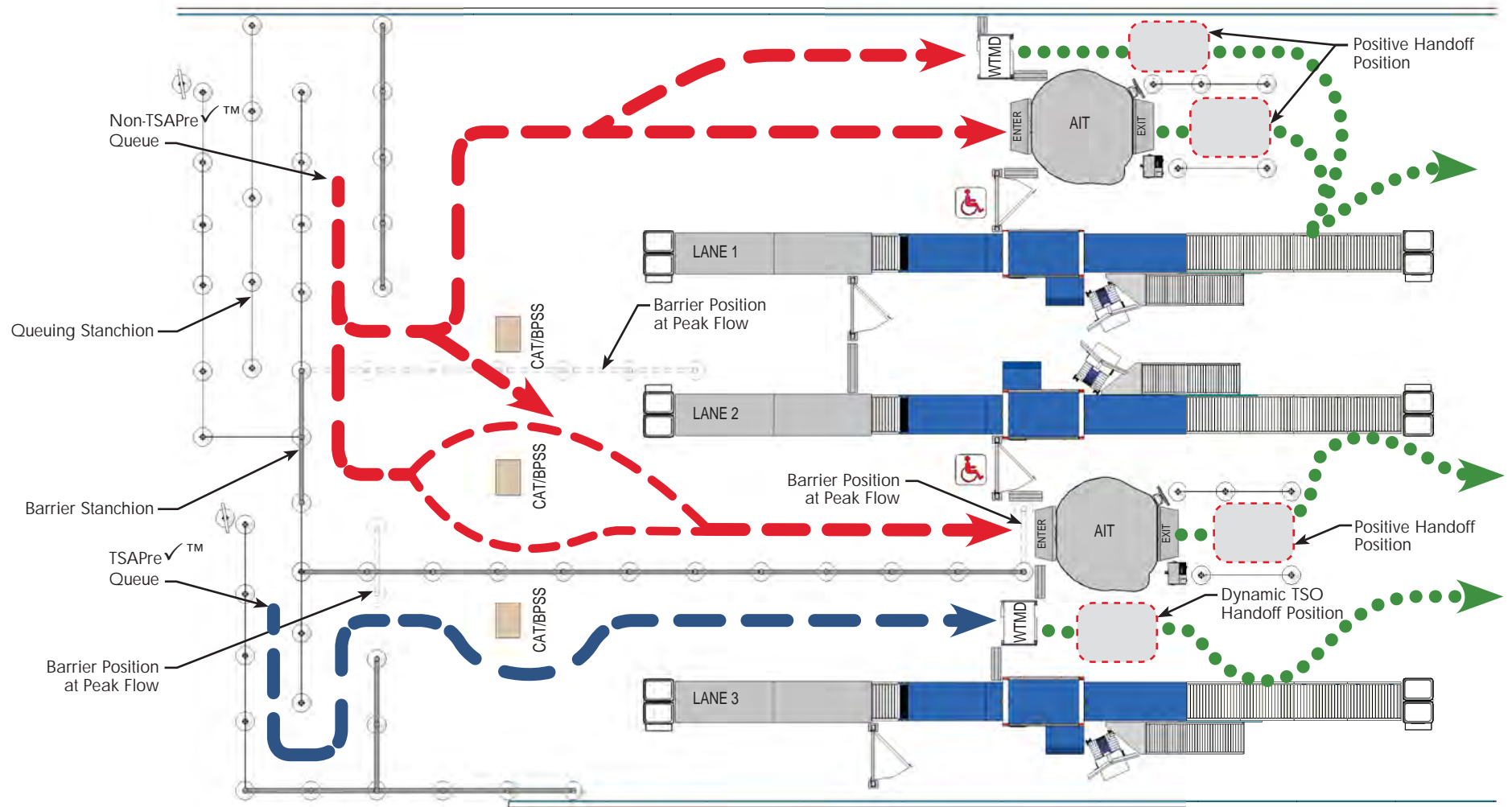

AIT Mod Set at Non-Peak TSAPreTM volume.
LANE 3 is the TSAPreTM platform.

Figure 3-2 AIT Peak Flow

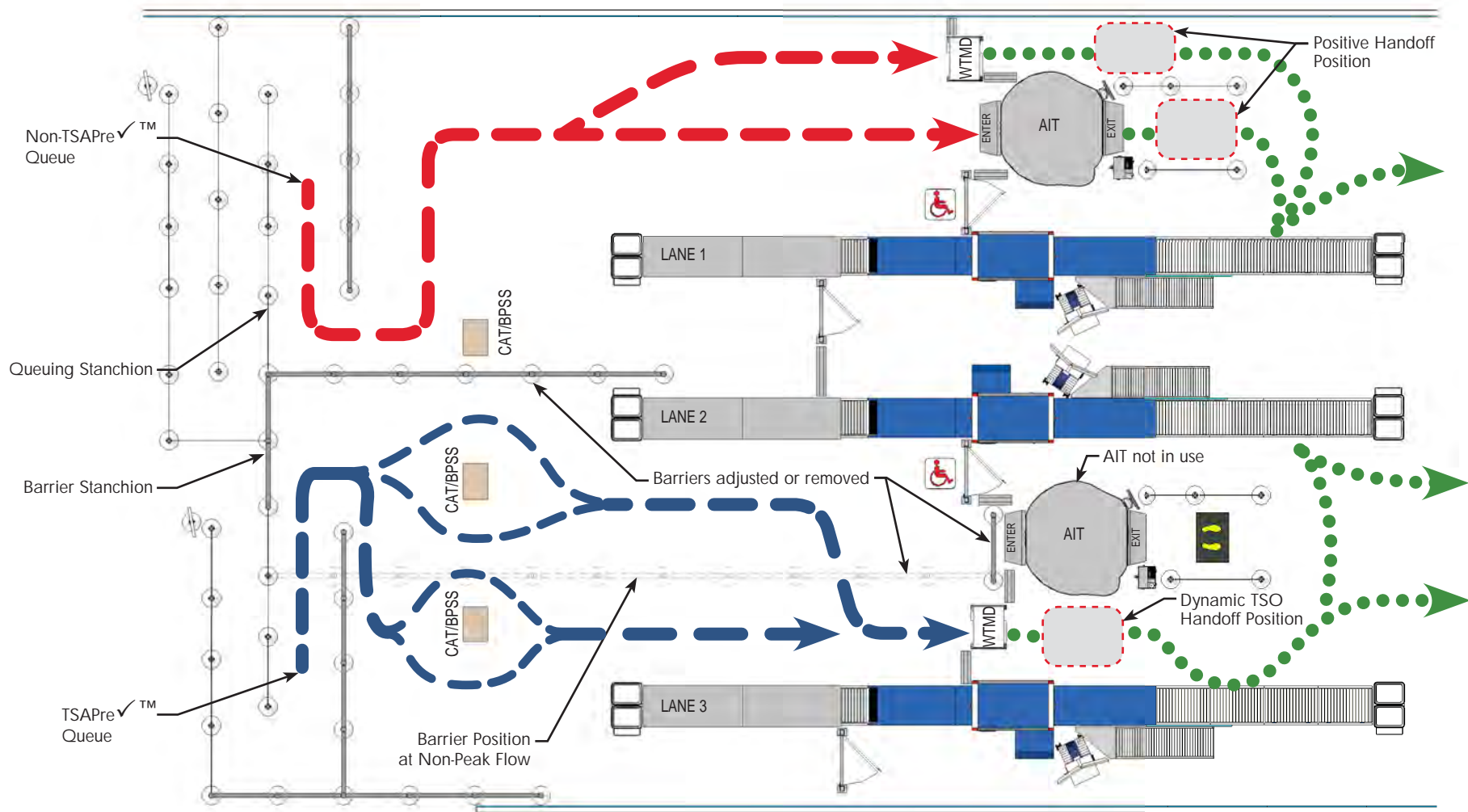

3.2 STANDARD SSCP ARRANGEMENT

The Standard SSCP Arrangement consists of AT2 equipment, a MDR, a WTMD, an AIT, passenger containment, and a secondary screening area that includes an ETD, BLS, AVS, and passenger/carry-on baggage inspection. This arrangement upgrades the AT1 to an AT2. The difference between the AT1 and the AT2 is the addition of an AVS, MDR, and a 4'-0" queuing conveyor for the Rapiscan and L3 AT2 only. The AT2 comes in the same orientations as the AT1. Refer to Section 2.5.1.

The structural floor must be evaluated prior to placement of the AT and the AIT since the live load a floor system can support varies. At checkpoints with only AT X-rays spaced a minimum of 5'-0" clear average of each other, the equipment will impact a maximum uniform area load of approximately 65 psf on the floor. At checkpoints with a combination of AT X-ray and AIT units, a minimum of 6'-0" clear average of each other, the equipment will impact a maximum uniform area load of approximately 85 psf on the floor.

Designers are reminded to consult applicable codes within their region of the country to determine the applicability and countermeasures to address seismic events for both brands. Brand manufacturers have brackets available for purchase.

The stanchions that form the exterior perimeter of the TDC podium should be barrier stanchions in order to deter passengers from bypassing this function. Strap stanchions can be detached too quickly and easily where barrier stanchions have to be disassembled, alerting TSA personnel and allowing time for a TSO to respond.

The following pages represent the Standard SSCP Arrangement in 2-D and 3-D. **Figure 3-3** is an isometric view of five lanes in an optimized layout. **Figure 3-4** is a plan view of the same 5-lane layout, but the recommended spacing between the screening and ancillary equipment is shown. These dimensions are guidelines to use when laying out a checkpoint. Adjustments to these dimensions may need to be made due to site conditions. This is acceptable as long as the spacing is within the desired range. Deviations from the

minimum and maximum spacing must receive OSC approval before implementation. Every attempt to achieve the dimensions listed in the table should be made when designing a checkpoint with Standard SSCP Arrangement equipment. The spacing requirements are the same regardless of the make and model of the screening equipment used.

It should be noted that the minimum possible distance between the WTMD and AIT should be maintained for each checkpoint. Decreased spacing between the equipment enhances the lane security by reducing the opportunity for contraband exchanges (via "handoff" of prohibited items) between yet-to-be screened AIT passengers and screened WTMD passengers and as they move parallel to one another through the lane. Travel distance between the AIT and WTMD should be minimized (5'-8") while preserving maintenance clearance. In Standard SSCP Arrangement, the recommended distance is 5'-8".

Figure 3-3 SSCP Standard Arrangement Five-Lane Layout

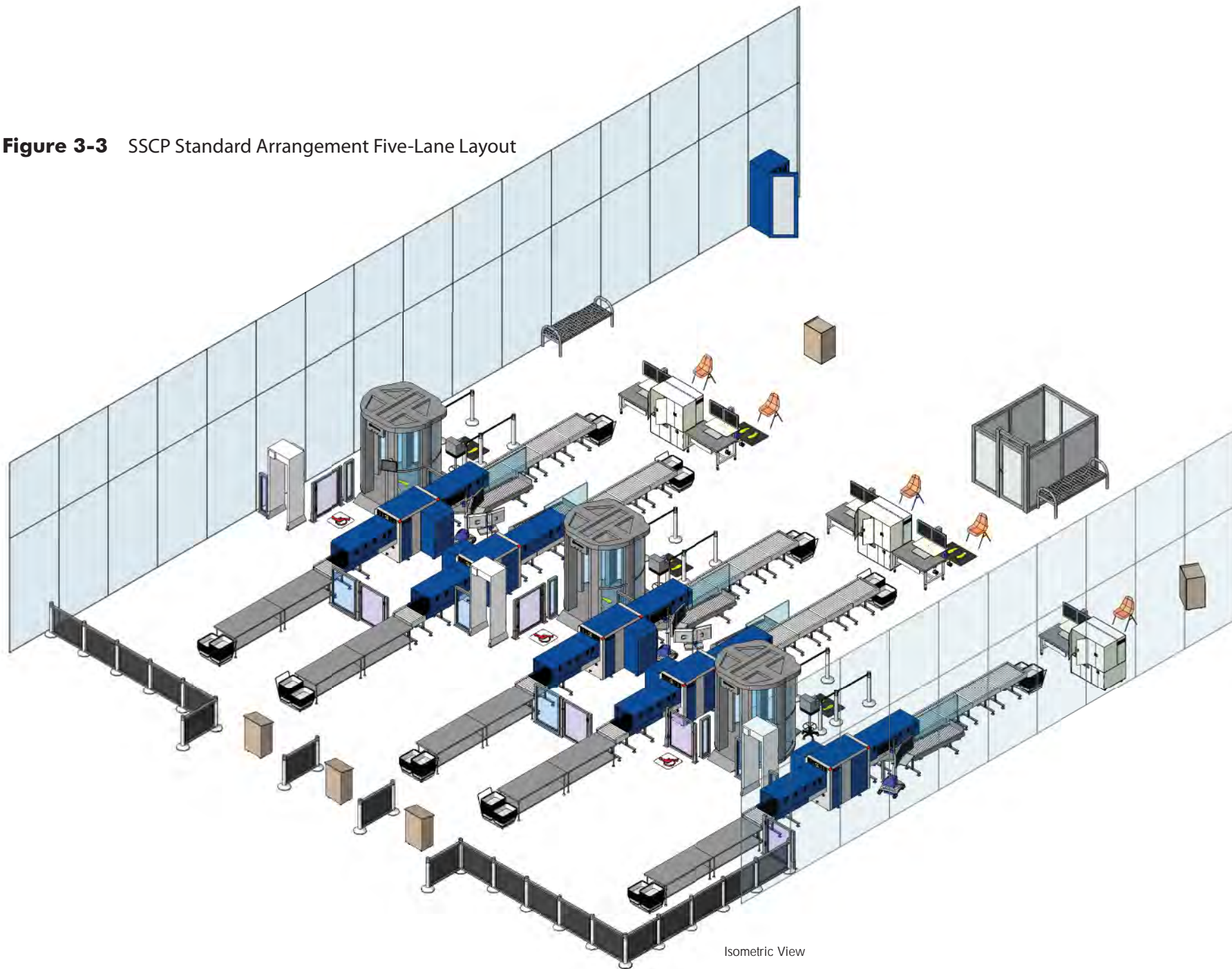
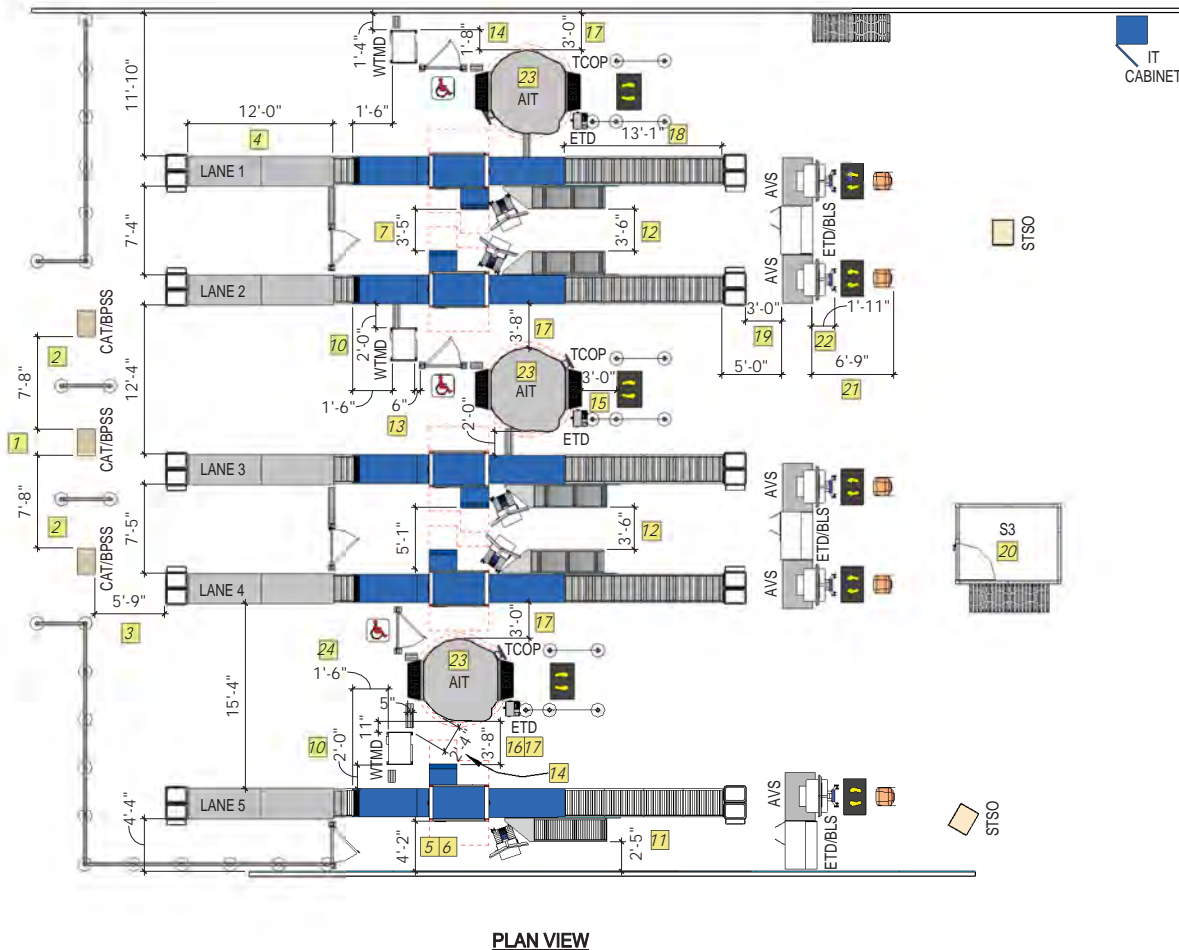

Figure 3-4 SSCP Arrangement Recommended Spacing



REFER TO SPECIFIC MANUFACTURER AND EQUIPMENT MODELS INDICATED IN SECTION XYZ AND OSC CAD BLOCKS FOR ACTUAL EQUIPMENT DIMENSIONS.

LEGEND

- Service area
- 1 3'-0" minimum queue lane width (not shown)
- 2 6'-0" - 8'-0" from podium edge to podium edge
- 3 4'-0" - 15'-0" from the TDC podium to nearest bin cart
- 4 12'-0" of divest tables
- 5 3'-0" minimum from bump-out to wall when bump-out is towards the operator (not shown)
- 6 4'-0" minimum from dome to wall when bump-out is towards the passengers
- 7 3'-0" minimum between back-to-back bump-outs when both bump-outs are towards the operators and the domes are aligned or staggered
- 8 4'-0" minimum between back-to-back dome and bump-out when one bump-out is towards the passengers, one bump-out is towards the operators, and the domes are aligned or staggered (not shown)
- 9 4'-0" minimum between back-to-back domes when both bump-outs are towards the passengers and the domes are aligned or staggered (not shown)
- 10 2'-0" minimum from WTMD to conveyor or dome
- 11 3'-0" from MDR to wall
- 12 2'-5" minimum from MDR to MDR for back-to-back lanes
- 13 12" maximum between ancillary or screening equipment separating the non-sterile area from the sterile area (not every location shown)
- 14 Minimum 5" in, 11" out, and 2'-6" diagonally from WTMD to AIT
- 15 3'-0" from AIT exit to passenger inspection mats
- 16 3'-0" minimum for passenger egress
- 17 3'-0" minimum for ADA passenger path of travel
- 18 12'-0" minimum of composure rollers
- 19 3'-0" minimum from bin cart to the secondary screening area to allow for TSO bypass or 5'-0" minimum from last composure roller to secondary screening area to allow for TSO bypass
- 20 6' x 8' Private Screening Room
- 21 6'-0" x 6'-0" minimum for passenger search at secondary screening area
- 22 18" - 22" from AVS to search table
- 23 9'-0" minimum height clearance for L3 AIT
- 24 1'-6" minimum WTMD to entry conveyor hood

This page is intentionally left blank.

4.0 SSCP ELECTRICAL REQUIREMENTS

The power and data requirements for each individual piece of security screening equipment are included in Section 2.0. This section attempts to describe all the electrical systems, specifically data, power, CCTV, and lighting required to support the checkpoint. Familiarity with these requirements will be essential when designing a new checkpoint or reconfiguring an existing checkpoint.

4.1 DATA REQUIREMENTS

The TSA HQ Office of Information Technology (OIT) and Security Technology Integrated Program (STIP) requires most powered security screening equipment to have two data drops consisting of flush-mounted 568B data jacks. Both drops, even though one is redundant, should be connected using Cat5/Cat5e/Cat6 data cable and terminated on the patch panel in the closest TSA IT cabinet located at or near the checkpoint. The data cable type should be based on the existing conditions at the checkpoint. The purpose of this connectivity is so that TSA HQ can review statistical data over the network from screening equipment for a particular airport and time period without having to go to the site.

Steps toward this goal were made under the High Speed Operational Connectivity (Hi-SOC) program where data outlets and cables for a limited number of locations were connected to the IT cabinet. As checkpoints are reconfigured, either the project owner's contractor or the TSA HQ Install, Move, Add, or Change (IMAC) Group gets involved to relocate and provide new data outlets and cables as needed to support new technology. If a checkpoint relocation or reconfiguration is initiated by the airport during an airport renovation, or a new checkpoint is being designed for a new terminal or airport as a part of an Airport Authority Mandate, the airport must restore the checkpoint to its previous state of connectivity ("make whole"). If a checkpoint reconfiguration is initiated by any group within TSA HQ as part of an optimization and safety effort, new technology deployment or any other checkpoint redesign initiative, the TSA will be responsible for restoring the checkpoint to its previous state of

connectivity ("make whole"), including development of the scope of work (SOW). Implementation in the field can occur via the TSA HQ Contractor or via the internal IMAC group. This will depend on the scope of work and the number of sites impacted.

In either scenario, a working group must be formed consisting of representatives from the Airport Authority, FSD staff, OSC, and STIP. The group should meet immediately via conference call once it has been determined that a checkpoint or checkpoints are going to be reconfigured. This action will ensure that ALL aspects of the checkpoint redesign have been identified and assigned to a specific group for action and funding. This team will organize the working group members, develop, review and approve the SOW. The OIT Field Regional Manager (FRM) should always be consulted when a checkpoint redesign is initiated.

Installation and/or relocation of Cat5e/Cat6 data cabling will meet or exceed the specifications listed in the TSA Office of Real Estate Services Field Locations Program of Requirements (POR) document dated July 2005. Refer to Section III – D Structured Cabling System Guidelines (Voice/Data). **Figure 4-1** illustrates all of the equipment that must be connected to the IDF IT cabinet and equipment that must be connected to other equipment such as the AT2 to the AVS.

At a minimum, the following guidelines should be considered when designing a new checkpoint or reconfiguring an existing checkpoint.

- If an existing TSA Main Distribution Frame (MDF)/Intermediate Distribution Frame (IDF) is within 295' of the SSCP:
 - » Verify that the existing switches have sufficient open ports to accommodate the required number of drops.
 - » Install an additional switch if the existing switch capacity will not accommodate the required number of drops.
 - » Punch down cabling from the individual SSCP devices in the patch panel of the IT cabinet.

- » Initiate IMAC group to install jumper cables from the patch panel to the switch and activate port. This is described later in this section.
- If there is no MDF/IDF within 295' of the SSCP:
 - » Install an appropriate IT cabinet. Refer to **Figure 4-3** for the IT cabinet specifications.
 - » Run fiber optic cable from the IT cabinet to an existing TSA MDF/IDF.
 - » Punch down cabling from the individual SSCP devices in the patch panel of the IT cabinet.
 - » Initiate IMAC group to install jumper cables from the patch panel to the switch and activate port.

The IMAC Process is the course of action required by TSA OIT to implement an IT request at a checkpoint. Who takes the lead and who funds the effort will all depend on the group initiating the work. For example, if OSC is deploying new technology at the checkpoint, then the OSC Regional Deployment Manager (RDM) would be responsible for making OIT aware of the airports and checkpoints receiving new equipment that require new or relocated data outlets and cabling. Once this initial contact has been made, a process will need to be identified for each group to execute.

The IMAC process needs to be initiated for the following, which takes 90 to 120 days to implement unless otherwise noted.

- Installation of a new IT cabinet.
- Relocation of an existing IT cabinet.
- Installation of additional IT equipment.
- Relocation or installation of new fiber.
- Relocation or installation of new T1 and/or Out of Band (OOB) Management Analog lines for monitoring modems in the IT cabinets. This takes approximately 45 to 60 days to implement.

The durations listed above are determined from the date when the SOW has been submitted by the OIT FRM and approved by the IMAC team. Since it can take up to several months to implement IT modifications, it is imperative to engage each team member as early as possible in order to avoid any gaps in IT services.

Figure 4-4 lists the specifications for the Kronos 4500 Time Clock Terminal. This clock should be located within 295' of the TSA MDF/IDF and it should utilize Power Over the Ethernet (POE). These terminals need to be deployed at TSA airports and offsite locations in support of the Electronic Time, Attendance, and Scheduling (eTAS) Program which monitors and tracks timekeeping of TSOs across the country. Refer to the TSA Kronos Terminal Installation and Configuration Guide Version 1.7 dated October 29, 2009 for additional information.

Figure 4-1 SSCP Data Connectivity Diagram

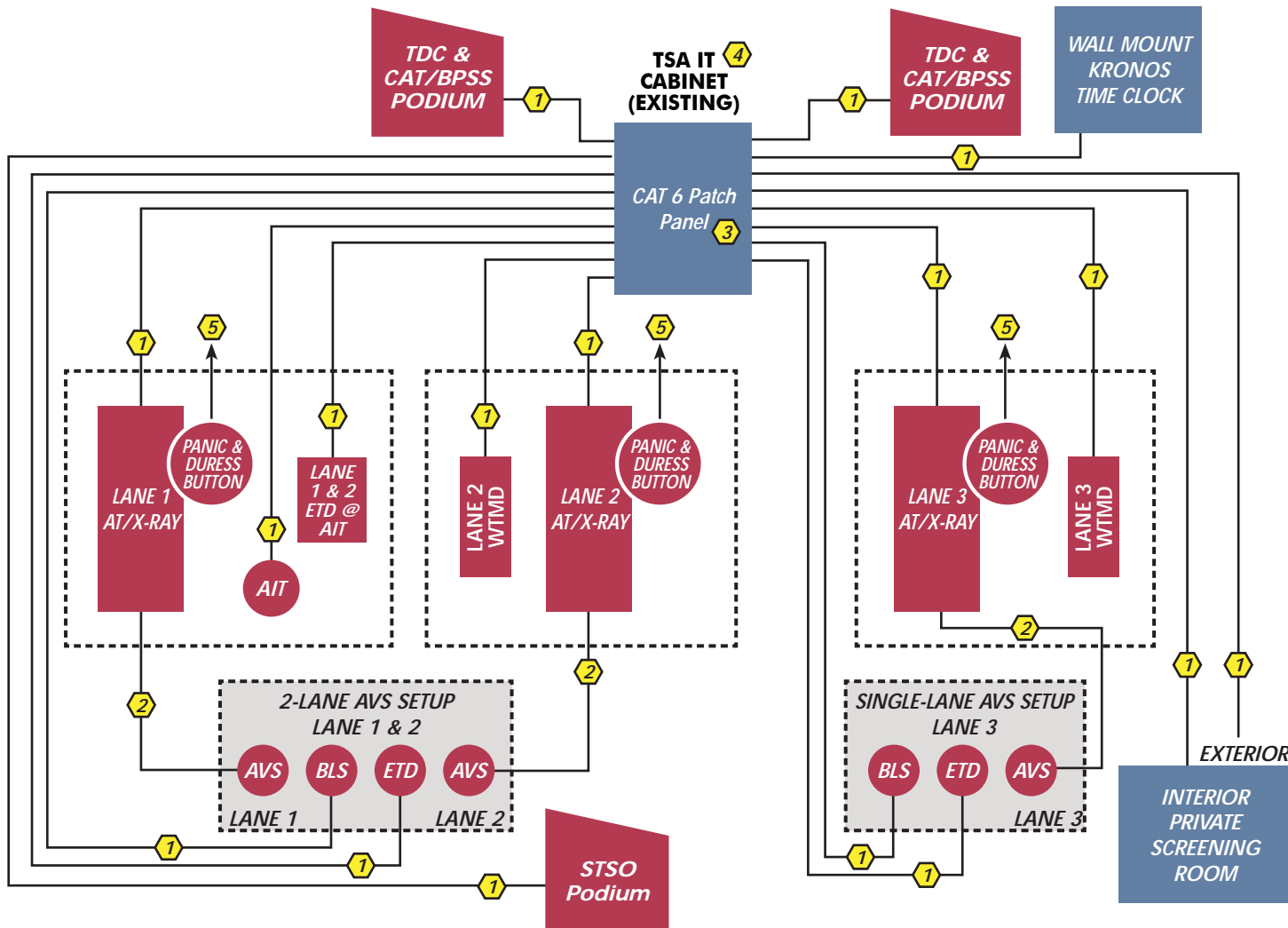

KEYED NOTES

- 1** (2) CAT 6 UTP CABLES ROUTED FROM THE TSA IT CABINET TO EACH DEVICED AS NOTED. TERMINATE ALL CAT 6 CABLE ON THE OUTLET END WITH A MODULAR RJ-45 CAT 6 RATED 568B JACK CONTAINED IN POKE OR FACEPLATE AS NOTED ON THE DRAWINGS. CONTRACTOR TO TERMINATE TSA CABINET END TO A CAT 6 RATED MODULAR RACK MOUNTED PATCH PANEL.
- 2** (2) CAT 6 UTP CABLE ROUTED FROM "AVS" TO "AT" AS NOTED ON THE ONE LINE DIAGRAM. TERMINATE BOTH DEVICE ENDS WITH A MODULAR RJ-45 CAT 6 RATED 568B JACK. TELECOM/ELECTRICAL CONTRACTOR SHALL COORDINATE INSTALLATION WITH SITE LEAD AND MANUFACTURER.
- 3** CONTRACTOR TO PROVIDE NEW PATCH PANEL(S) IN QUANTITY AS INDICATED ON THE DRAWINGS. PATCH PANEL SHALL HAVE A RATING OF CAT 6.
- 4** EXISTING TSA IT CABINET, SHOWN FOR REFERENCE ONLY.
- 5** PANIC DURESS BUTTON, CONTRACTOR TO FIELD VERIFY HEAD-END LOCATION FOR TERMINATION OF ANY NEW WIRING. UTILIZE COMMUNICATIONS PATHWAY TO "AT" LOCATION.

Figure 4-2 Power & Data Requirements Table

Power					Data
Device/Space	Circuit Type	Voltage	Receptacle Type*	Comments	Cable Type/Location/Comments
RAPISCAN 620DV AT1	DEDICATED 20A	125V	NEMA 5-20R	15' POWER CORD FROM AT TO RECEPTACLE	2- CAT 6 ROUTED TO TSA IT CABINET (1 PRIMARY 1 REDUNDANT)
RAPISCAN 620DV AT2	DEDICATED 20A FOR X-RAY	125V	NEMA 5-20R	15' POWER CORD FROM AT TO RECEPTACLE	2- CAT 6 ROUTED TO TSA IT CABINET (1 PRIMARY 1 REDUNDANT) PLUS 2- CAT 6 ROUTED DIRECT (NOT THROUGH PATCH PANEL) TO AVS (MAINTAIN LANE ASSOCIATION). (1 PRIMARY 1 REDUNDANT, REDUCTION NOT ALLOWED)
RAPISCAN 620DV AT2 QUEUING CONVEYOR	DEDICATED 20A FOR QUEUING CONVEYOR, MAXIMUM OF 4 PER CIRCUIT	125V	NEMA 5-20R	15' POWER CORD FROM QUEUING CONVEYOR TO RECEPTACLE	NOT APPLICABLE
RAPISCAN AVS	NON-DEDICATED 15A	125V	NEMA 5-20R	5' POWER CORD FOR TWO MONITORS AND ONE PC TOWER OF THE AVS TO THE POWER STRIP MOUNTED TO THE TSA SEARCH TABLE. 6' POWER CORD FROM THE POWER STRIP TO THE RECEPTACLE. CIRCUIT SHARED WITH ETD AND BLS AT THE SAME SEARCH AREA VIA POWER STRIP (FIGURE 2-12,2-16).	2- CAT 6 ROUTED DIRECT (NOT THROUGH PATCH PANEL) TO XRAY (MAINTAIN LANE ASSOCIATION). (1 PRIMARY 1 REDUNDANT, REDUCTION NOT ALLOWED)
SMITHS 6040aTiX AT1/AT2	DEDICATED 20A	125V	NEMA 5-20R	15' POWER CORD FROM AT TO RECEPTACLE	2- CAT 6 ROUTED TO TSA IT CABINET (1 PRIMARY 1 REDUNDANT) PLUS 2- CAT 6 ROUTED DIRECT (NOT THROUGH PATCH PANEL) TO AVS (MAINTAIN LANE ASSOCIATION). (1 PRIMARY 1 REDUNDANT, REDUCTION NOT ALLOWED)
SMITHS AVS	NON-DEDICATED 20A	125V	NEMA 5-20R	5' POWER CORD FOR TWO MONITORS AND ONE PC TOWER OF THE AVS TO THE POWER STRIP MOUNTED TO THE TSA SEARCH TABLE. 6' POWER CORD FROM THE POWER STRIP TO THE RECEPTACLE. CIRCUIT SHARED WITH ETD AND BLS AT THE SAME SEARCH AREA VIA POWER STRIP (FIGURE 2-12,2-16).	2- CAT 6 ROUTED DIRECT (NOT THROUGH PATCH PANEL) TO XRAY (MAINTAIN LANE ASSOCIATION). (1 PRIMARY 1 REDUNDANT, REDUCTION NOT ALLOWED)
L3 ACX 6.4- MV AT2	DEDICATED 20A	125V	NEMA 5-20R	15' POWER CORD FROM AT TO RECEPTACLE. OPERATOR CART IS POWERED BY THE AT. FIELD DATA RECORDING SYSTEM (FDRS) IS POWERED BY THE AT. UPS IS INTERNAL TO AT	2- CAT 6 ROUTED TO TSA IT CABINET (1 PRIMARY 1 REDUNDANT) PLUS 2- CAT 6 ROUTED DIRECT (NOT THROUGH PATCH PANEL) TO AVS (MAINTAIN LANE ASSOCIATION). (1 PRIMARY 1 REDUNDANT, REDUCTION NOT ALLOWED)
L3 AVS	NON-DEDICATED 20A	125V	NEMA 5-20R	6' POWER CORD FOR ONE MONITOR AND PC TOWER OF THE AVS TO THE UPS. 6' POWER CORD FROM UPS TO POWER STRIP MOUNTED TO THE TSA SEARCH TABLE. 6' POWER CORD FROM THE POWER STRIP TO THE RECEPTACLE. CIRCUIT SHARED WITH ETD AND BLS AT THE SAME SEARCH AREA VIA POWER STRIP (FIGURE 2-12,2-16).	2- CAT 6 ROUTED DIRECT (NOT THROUGH PATCH PANEL) TO XRAY (MAINTAIN LANE ASSOCIATION). (1 PRIMARY 1 REDUNDANT, REDUCTION NOT ALLOWED)

Figure 4-2 Power & Data Requirements Table (cont.)

Power					Data
Device/Space	Circuit Type	Voltage	Receptacle Type*	Comments	Cable Type/Location/Comments
L3 PRO VISION AIT	DEDICATED 20A	125V	NEMA 5-20R	25' POWER CORD FROM AIT TO UPS. 10' CORD FROM UPS TO AIT. 16' USB CABLE FROM AIT TO UPS. CABLES CANNOT BE RUN UNDER ENTRY/EXIT RAMPS. TCOP CANNOT BE MOUNTED ON CONTROL LEG.	2- CAT 6 ROUTED TO TSA IT CABINET (1 PRIMARY 1 REDUNDANT)
WTMD	DEDICATED 20A	125V	NEMA L5-15R (TWISTLOCK)	WTMD'S CAN BE GROUPED UP TO 10 PER CIRCUIT. WTMD MUST BE DEDICATED "WTMD-ONLY" CIRCUIT. 13' POWER CORD FROM WTMD TO RECEPTACLE. 18" MINIMUM SPACING FROM WTMD LEG TO ELECTRICAL CONDUIT OR DEVICE.	2- CAT 6 ROUTED TO TSA IT CABINET (1 PRIMARY 1 REDUNDANT)
ETD & ETD @ AIT	NON-DEDICATED 20A	125V	NEMA 5-20R	NON-DEDICATED CIRCUIT, MAY BE SHARED WITH AVS AND BLS CIRCUIT AT THE SAME SEARCH AREA VIA POWER STRIP (FIGURE 2-12,2-16). MINIMUM CORD LENGTH 6'-6"	2- CAT 6 ROUTED TO TSA IT CABINET (1 PRIMARY 1 REDUNDANT)
BLS	NON-DEDICATED 20A	125V	NEMA 5-20R	NON-DEDICATED CIRCUIT, MAY BE SHARED WITH AVS AND BLS CIRCUIT AT THE SAME SEARCH AREA VIA POWER STRIP (FIGURE 2-12,2-16). MINIMUM CORD LENGTH 6'-6"	2- CAT 6 ROUTED TO TSA IT CABINET (1 PRIMARY 1 REDUNDANT)
TDC & CAT/BPSS	NON-DEDICATED 20A	125V	NEMA 5-20R	POWER CORD LENGTH UNKNOWN AT THIS TIME.	2- CAT 6 ROUTED TO TSA IT CABINET (1 PRIMARY 1 REDUNDANT)
STSO	NON-DEDICATED 20A	125V	NEMA 5-20R	6'-10' CORD FROM LAPTOP TO RECEPTACLE	2- CAT 6 ROUTED TO TSA IT CABINET (1 PRIMARY 1 REDUNDANT)
PRIVATE SCREENING INTERIOR	NON-DEDICATED 20A	125V	NEMA 5-20R	REFER TO FIGURE 2-34 FOR RECEPTACLE LOCATION	2- CAT 6 ROUTED TO TSA IT CABINET (1 PRIMARY 1 REDUNDANT)
PRIVATE SCREENING EXTERIOR	NON-DEDICATED 20A	125V	NEMA 5-20R	REFER TO FIGURE 2-34 FOR RECEPTACLE LOCATION	2- CAT 6 ROUTED TO TSA IT CABINET (1 PRIMARY 1 REDUNDANT)
PANIC/DURESS					VERIFY HEAD END, USE COMMON FEED AT XRAY
KRONOS (ETA)	POWER OVER ETHERNET (POE)	N/A	N/A	REFER TO PLANS FOR LOCATION	2- CAT 6 ROUTED TO TSA IT CABINET (1 PRIMARY 1 REDUNDANT)

Figure 4-3 IT Cabinet

Equipment	Size	Quantity	Power Requirements	IT Requirements	Additional Information
IT Cabinet	Size 24H 24.0"H x 27.3"W x 30.0"D Weight: 97 lbs	1 or more per checkpoint depending on size	For 24H, 36H and 48H: <ul style="list-style-type: none"> • Dedicated • 30A, 125V, 3KVA/Cabinet • 2-Pole, 3-Wire Grounding • NEMA L5-30R Receptacle • 3KVA UPS • 6' power cord from the IT cabinet to the receptacle 	<ul style="list-style-type: none"> • Size patch panels to accommodate all TSA data outlets at the checkpoint plus 100% spares, minimum. • Size giga bit network switch to accommodate all data outlets in checkpoint plus 10%. • Provide a minimum of four pair single mode fiber optic cable from IT cabinet to the TSA main distribution frame. 	<ul style="list-style-type: none"> • 30" front and rear access is required. • These cabinets will receive all data communication lines from the SSCP, so the cabinet should be located as close to the SSCP as possible, but in a secure location. Careful consideration needs to be given to the IT cabinet location because the exhaust fan for cooling can be loud when located in a confined space with TSA or airport personnel. • Equipment racks can be loaded into the cabinet from the front or the back at the location where the cabinet is installed. Although not required, side access would improve rack accessibility and TSA personnel mobility around the cabinet. • Refer to Program of Requirements dated July 2005, Section III-D for labeling, cable management and administration of IT cabinet. • Refer to Program of Requirements dated July 2005, Section III-D for acceptance testing of IT circuits. • Wall-mounted cabinets are an option in some instances, but must adhere to all applicable local codes and standards. Recommend consultation with the Field Regional Manager (FRM) when considering a wall-mounted alternative.
	Size 36H 36.0"H x 27.3"W x 30.0"D Weight: 124 lbs				
	Size 48H 48.0"H x 27.3"W x 30.0"D Weight: 151 lbs				
	Size 60H 60.0"H x 27.3"W x 30.00"D Weight: 246 lbs				
	Size 72H 72.0"H x 27.3"W x 30.0"D Weight: 274 lbs				
			For 60H and 72H: <ul style="list-style-type: none"> • Dedicated • 30A, 208V, 6KVA/Cabinet • 2-Pole, 3-Wire Grounding • NEMA L6-30R Receptacle • 6KVA UPS • 8' power cord from the IT cabinet to the receptacle 		

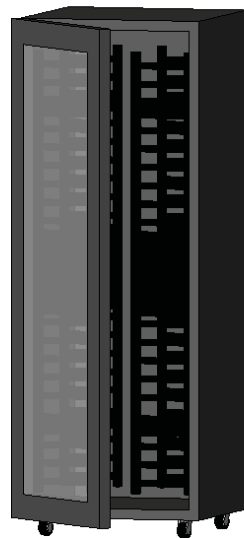

Isometric View

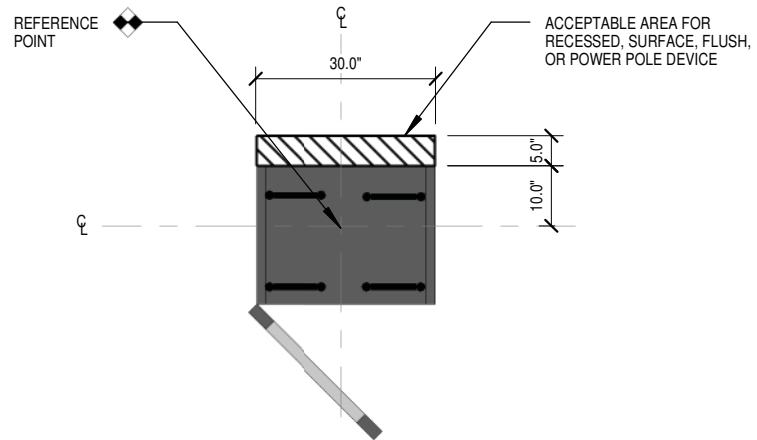

PLAN VIEW

Figure 4-4 Kronos Time Clock

Equipment	Size	Quantity	Power Requirements	IT Requirements	Additional Information
Kronos 4500 Terminal	11.7"H x 10.7"W x 4.0"D	1 per airport or checkpoint depending on TSO population	<ul style="list-style-type: none"> All power over ethernet 	<ul style="list-style-type: none"> Data Drop = 2 Cat5e / Cat6 cable Kronos Terminal placement should be within 295' of existing TSA IT Cabinet. Host communication via Ethernet (10/100 Mbps auto sensing) Verify switch ports exist in TSA IT Cabinet prior to installation. 	<ul style="list-style-type: none"> Locate Kronos Terminal in a secure TSA area. Place in protected area to avoid physical damage. Mount per ADA requirements. Allowed high side reach shall be no more than 54" and the allowed low side reach shall be no less than 9" AFF. Avoid checkpoint high traffic areas such as exit lanes, queuing areas, public seating, and composure areas. No exposed cabling or power outlets allowed. TSA preferred install is to mount the clock over a LAN port and power outlet.

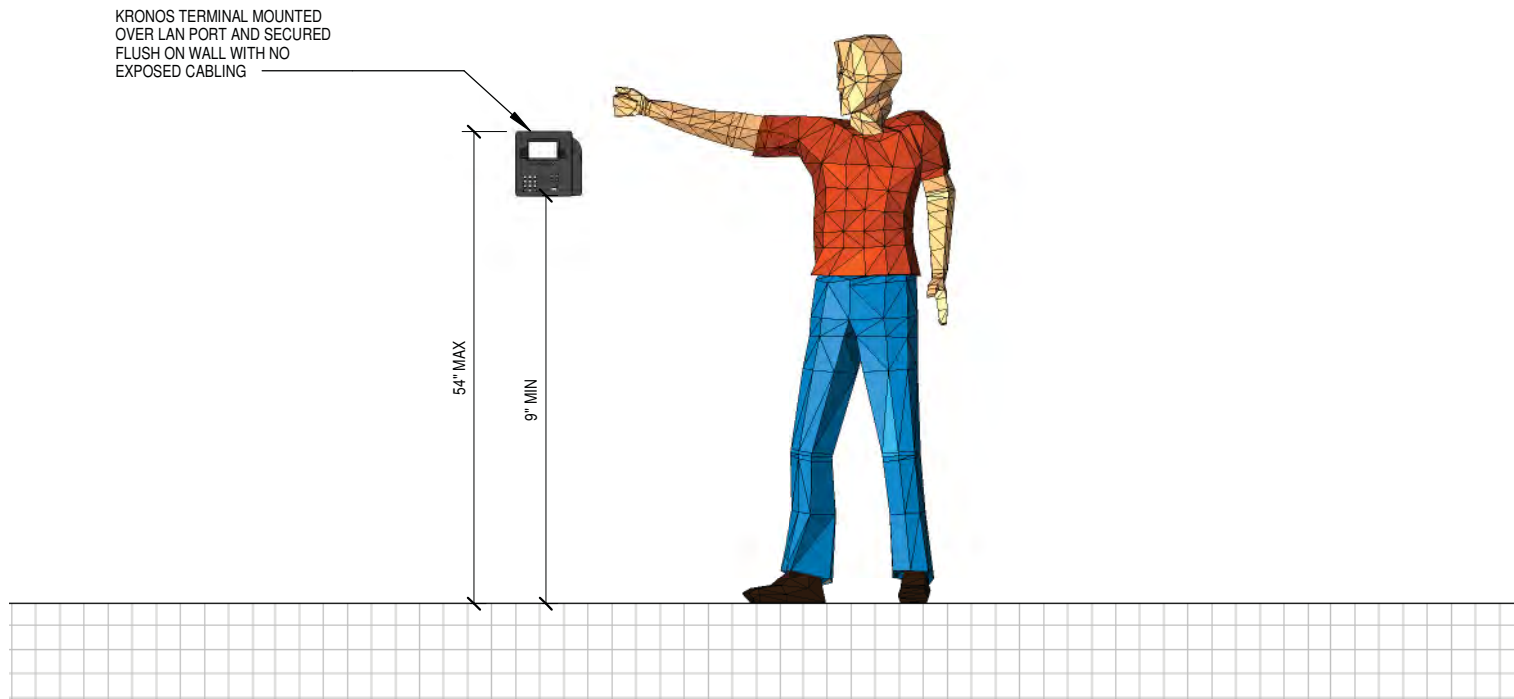

ELEVATION

4.2 POWER REQUIREMENTS

Most of the new technology being added to the checkpoint today and in the future requires a dedicated circuit. It is recommended to plan for this now, especially if the existing electrical panel(s) has available capacity. **Figure 4-5** illustrates all of the equipment that must be connected to the SSCP power panelboard. All checkpoint circuits should be located together in the same electrical panel or panels with non-dedicated circuits grouped together when possible. This is not possible to do for the WTMD even though the load is approximately 1A. WTMDs can only share a circuit with other WTMDs otherwise the units will not function properly. The checkpoint electrical engineer should not assume an existing circuit is dedicated or expect the electrical contractor to trace an existing circuit and remove any excess load during construction. For new checkpoint design and checkpoint reconfiguration, new dedicated circuits should be provided for most security screening equipment. Each dedicated circuit should have its own neutral. There should be no common neutrals used for any checkpoint equipment circuits. This is necessary to prevent accidental over-voltage conditions and potential equipment damage should a neutral conductor be interrupted.

The electrical panel should be located as close as possible to the checkpoint. Each SSCP should have an electrical panel located in a secured area located at or near the SSCP and accessible by TSA staff. This may require a new electrical panel power feed with a transformer to step the voltage down from 480V, 3-phase secondary distribution power to 120/208V power, which is the standard voltage for checkpoint equipment. SSCP panels can vary in size from 100A, 3-phase all the way up to 225A, 3-phase depending on the number of lanes at the checkpoint. Transformer sizes can vary from 30kVA all the way up to 75kVA depending on the SSCP panelboard size. These panels and transformers are standard electrical items that are readily available throughout the continental United States and should not require a significant lead time.

During design, it is important for the electrical engineer to determine the existing electrical system capacity available for checkpoint equipment. Field verification of the existing electrical panel loads and availability of power to support new equipment loads is essential. Circuits from existing electrical panels should be used when available as indicated by the panelboard and corresponding panel schedule that serves the checkpoint. Understand, however, that the panel schedule can often lack sufficient detail in regard to what equipment the circuit is feeding. Sometimes there are other loads piggy-backed onto a supposedly spare circuit or even a circuit feeding checkpoint equipment. A load study of the intended checkpoint power source that satisfies the requirements of NEC 220.87 is strongly recommended.

In some cases, a new electrical panel may be required for new circuits in support of a new checkpoint or reconfiguration of an existing checkpoint. This should be determined during the design phase by the electrical engineer and brought to the attention of TSA HQ immediately. When TSA HQ is funding the project, they must approve the cost of the new panel during the design phase as there could be impacts to the planned budget. This is only for deployment projects. An airport could provide a new panel at any time.

The electrical design of a new checkpoint or reconfiguration of an existing checkpoint must meet all applicable national and local codes in addition to any airport, state, county, and/or city requirements, depending on the Authority Having Jurisdiction (AHJ). Uninterrupted Power Supply (UPS) backup power is not required for SSCPs, although it may exist, or be required at some sites where power conditions are unstable and/or unreliable.

Figure 4-5 SSCP Power Connectivity Diagram

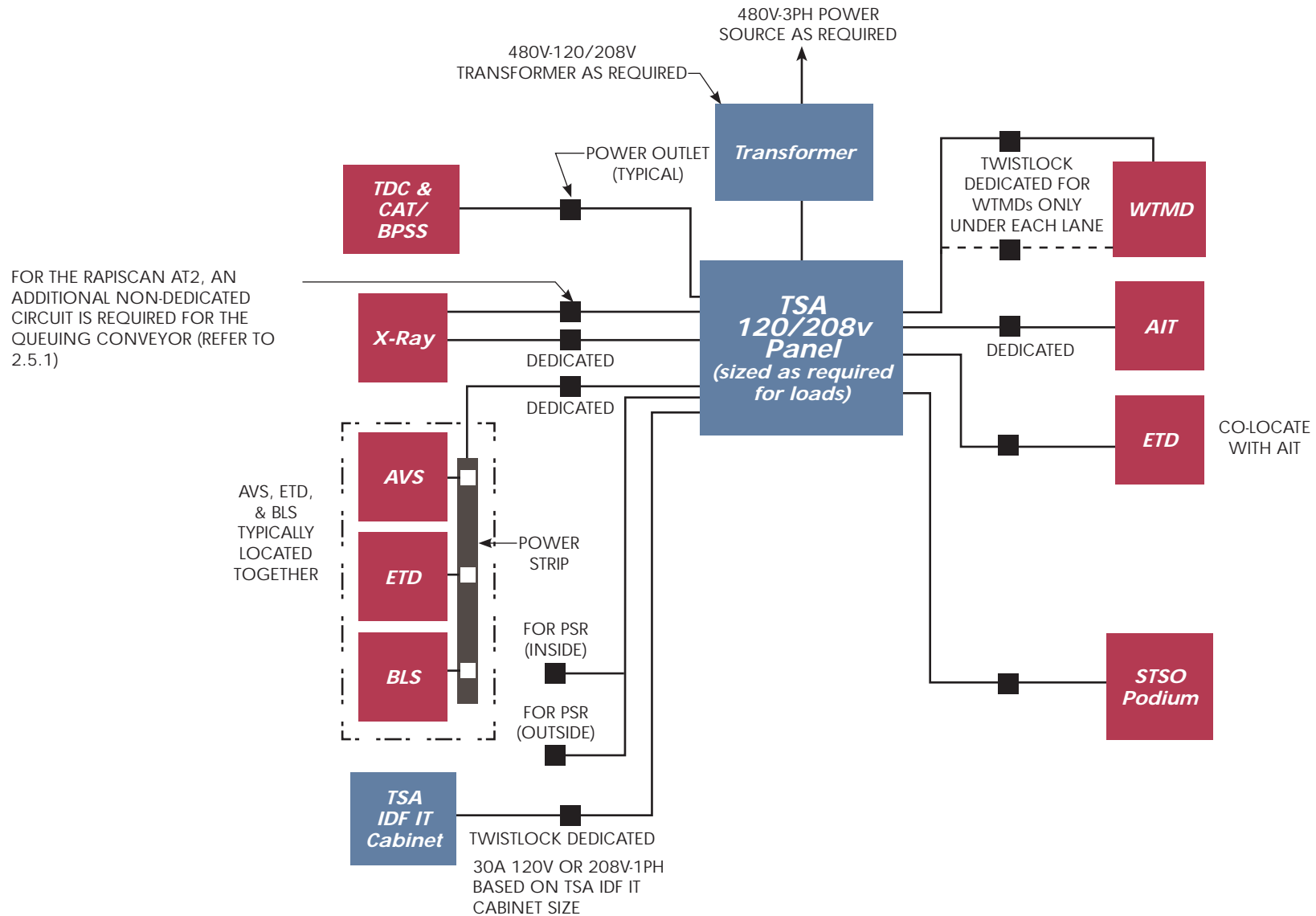

4.3 POWER/DATA RECEPTACLES

In **Figure 4-7**, there are nine types of TSA-approved electrical distributions and/or devices for SSCPs. In order of preference, TSA would like SSCP equipment to be powered in the following manner unless the Airport Authority states otherwise.

1. In-floor Walkerduct system
2. Modular surface-mounted pedestals in the floor and wall
3. Recessed power/data poke-through devices in the floor
4. Flush power/data poke-through devices in the floor and wall
5. Made-up surface-mounted monuments in the floor and wall (“tombstone”)
6. Ceiling or floor-supported power/data poles
7. Multiplex surface box
8. Recessed cast-in-place floor boxes
9. Self-supporting truss system

For airports that are renovating or building new terminal buildings, consideration should be given to utilizing an in-floor Walkerduct system. This system has a flexible construction comprised of modular components that can support a large capacity and provide easy access to wiring and cables in the floor. The future needs of TSA can be met without disturbing the flooring by removing, relocating, or adding components. The floor ducts are available in 6”, 12”, 18”, and 24” widths and 2-1/2” and 3-1/4” depths and can support 2,000 -2,400 lbs. of concentrated load depending on the duct size chosen. Installation will require cutting a trench that does not conflict with the structural components in the floor slab such as reinforcing rods, steel, existing in-floor devices, conduits, etc. The airport may incur higher costs up front, but over time, the flexibility provided prevents invasive and costly electrical device relocation. The airport A&E firm should coordinate closely with the airport and TSA OSC when designing this type of system to ensure that the needs of both parties are met.

TSA prefers that modular surface-mounted pedestals be located underneath x-ray rollers. This type of receptacle is highly versatile and require a smaller floor penetration. When a modular surface-mounted pedestal is not ideal, TSA prefers the Wiremold Evolution Series Model 6AT/8AT recessed poke-through because of the flexibility it provides when installed flush in the floor and the amount of receptacles, data jacks, grommet openings, and connectors it can hold within one device. This receptacle is ideal for high traffic areas and for locations with moving equipment. The downside is that a 6” core drill is required which is often a concern to an airport or the AHJ, as they do not want to impact the structural integrity of the floor. The location of the poke-throughs with respect to the structural framing, quantity of poke-throughs, and proximity to other poke-throughs must be carefully evaluated by the checkpoint electrical and structural engineer. Although the poke-through is identified as being “recessed”, the cover actually sits slightly above the floor. This is acceptable at most locations within the checkpoint except for the TDC and CAT/BPSS, STSO podium, and outside the Private Screening Room. These three locations should have a truly recessed poke-through because the equipment at these locations is not static and TSA wants the flexibility to make adjustments to the equipment in the future without creating trip hazards to passengers and personnel. This truly recessed poke-through can be achieved by providing a structural detail on the construction drawings that specifies for the contractor to core drill a hole approximately ¼” larger than the recessed poke-through cover so that the lip of the cover sits down in the floor. Refer to **Figure 4-6**. This installation is required when power/data is provided to these locations from the floor. Power poles can be used at these locations when a checkpoint is slab-on-grade or power poles are the preferred method of power and data distribution at the checkpoint.

When a checkpoint has a seismic structural slab-on-grade, terrazzo floors or high ceilings with an open plan, it can be a challenge to provide power and data to checkpoint equipment. Freestanding,

Figure 4-6 Recessed Poke-Through Installation Detail

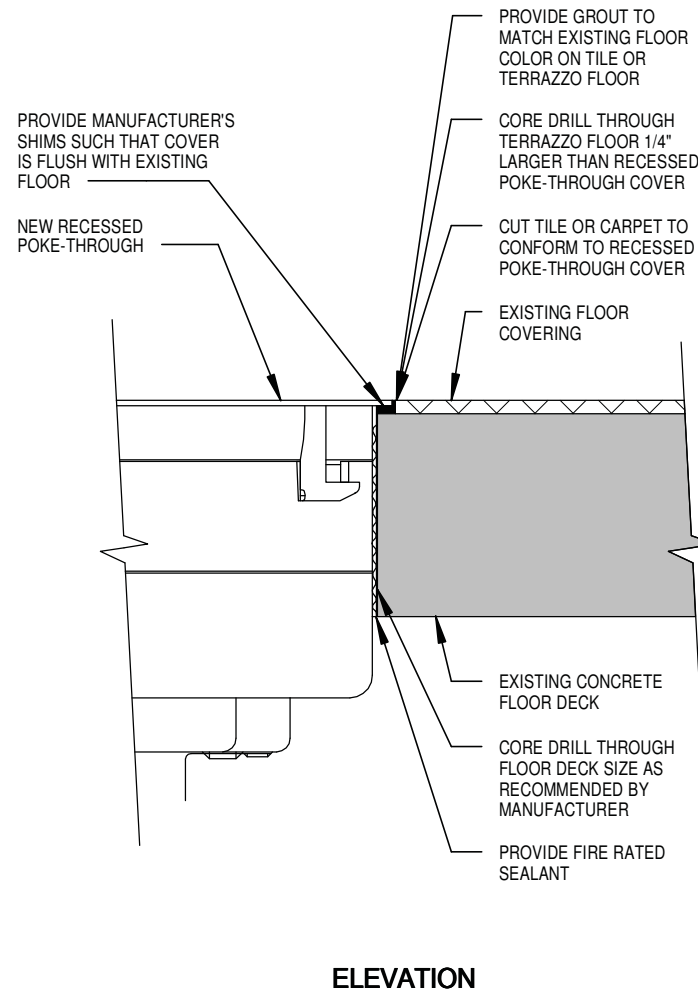

self-supporting, movable overhead truss systems or modular raised access flooring are viable solutions that have been implemented at a handful of airports in these circumstances. While these options are more expensive up front than some of the other options, they provide TSA a great deal of flexibility to reconfigure the checkpoints in the future or deploy more equipment without incurring significant infrastructure costs.

Power and data receptacles should be of high quality industrial standard to accommodate the high volume traffic at the SSCP. All should be properly mounted and fire-proofed. All power/data recessed or flush poke-through devices, modular or made-up surface boxes, power poles, fittings, raised access flooring, self-supporting truss systems, or in-floor Walkerdect systems must be coordinated with the Airport Authority. Typically, the airport prefers consistency in the type, finish, and color of electrical devices. So what is typically used throughout the terminal should also be used at the checkpoint. Exceptions may occur if the AHJ wants to minimize the addition of new core drills or wants to have flexibility to relocate the SSCP in the future. The checkpoint electrical engineer should confirm with the Airport Authority if the electrical distribution needs to match what currently exists at the checkpoint today or if it should be changed to match the terminal or to support future needs.

The airport and/or the AHJ may also want to evaluate floor core sizes and quantities as well as locations of any new electrical trenches. Airports with terrazzo floors are especially concerned about excessive penetrations in the floors and having areas where the patching is executed poorly. The airport may prefer modular or made-up surface boxes which require only a 1" to 3" core in lieu of recessed poke-through devices which require a 6" to 8" core. While the surface boxes require a smaller core, more boxes would be required to support all the planned TSE, hence more floor coring. A comparison of this is presented in the following section. If possible, the electrical approach should be discussed with the AHJ as early in

the project as possible in order to prevent any delays with the permit. Every attempt to re-use existing floor cores should be made when reconfiguring an existing checkpoint.

Acceptable locations for receptacles are included on the plan views for the equipment in Section 2.0. Recessed, flush, or surface devices should be positioned in such a way as to avoid trip hazards for both passengers and TSA personnel. The TRX or AT dome is approximately 2-3/4-inch above finished floor (AFF); therefore, pedestals, monuments, devices, or fittings located underneath the X-ray dome will not provide sufficient space to accept a plug. These should be located approximately 18" clear of the dome under the infeed or the outfeed depending on the equipment being fed. Under special circumstances only, an existing floor core located underneath an X-ray dome can be reused by providing a junction box on top of the core and extending it with rigid or flexible conduit to a surface box located under the infeed or the outfeed.

Receptacles should be located within reach of the equipment cords. The equipment cord lengths are included in the tables above the plan views in Section 2.0. Extension cords for permanently installed equipment are unacceptable if the equipment cord is too short to reach a receptacle. Equipment cords must be secured to the floor with tape, pancake raceway, cord clips, etc. Equipment cords should not be placed across passenger walkways or TSA working paths, nor should they be run underneath anti-fatigue mats or the AIT units where they may become a trip hazard, damaged from traffic, or be an NEC violation.

Care must also be taken to ensure that electrical receptacles are protected from damage or inadvertent contact by equipment, passengers, and/or TSA personnel. The receptacles for most SSCP equipment are straight blade NEMA 5-20R except for the WTMD, AutoEDS, and the IT cabinet where the receptacle needs to be twistlock to prevent power cords from being accidentally

disconnected. All data jacks should be flush-mounted with the receptacle housing with no loose wires extending from the housing. Any unused ports should be covered.

Duplex outlets that are split-wired with separate circuits to each receptacle must be fed from a two-pole circuit breaker or two side-by-side single-pole circuit breakers that have an approved link between the circuit breaker operator handles in order to meet the requirements of 2008 NEC 210.7 (B). The 2008 NEC 210.7 (B) states, "where two or more branch circuits supply devices or equipment on the same yoke, a means to simultaneously disconnect ungrounded conductors supplying those devices shall be provided at the point at which the branch circuits originate."

When existing recessed or flush poke-throughs, modular or made-up surface boxes are no longer needed at an SSCP, the checkpoint designer should specify for the contractor to perform the following tasks.

- Remove the power/data outlets and devices.
- Pull and remove the existing wiring back to its source.
- Repair the floor core opening to restore the floor slab to its original integrity.
- Install a flush cover plate, as required, for the type of outlet device removed.

Figure 4-7 Power/Data Device Distribution









Item	Service Type	Description	Pro	Con	Recommendation
1	Walkerduct 	Walkerduct In-floor raceway system	<ul style="list-style-type: none"> Provides flexibility for relocating SSCP power/data outlets. Best suited for new checkpoints/terminals. 	<ul style="list-style-type: none"> Requires careful layout and coordination to obtain the desired flexibility features. Can only be used for new checkpoint or when checkpoint is closed for a period of time. High cost 	<ul style="list-style-type: none"> Recommended for existing airport building shell renovations and new SSCP construction.
2	Modular Surface Box 	Pedestal poke-through with a 2-compartment box <ul style="list-style-type: none"> 9.25"W x 4.63"D x 2.63"H; 2-3" hole/box, dependent on manufacturer 	<ul style="list-style-type: none"> 2-3" hole in floor depending on manufacturer UL listed assembly Fire-rated A cover plate can be added if location is abandoned. Supports any outlet configuration 	<ul style="list-style-type: none"> Not flush ~ trip hazard Floor X-ray required in order to avoid existing steel. Not attractive The plug is above floor level and can be knocked out. 	<ul style="list-style-type: none"> Recommended at checkpoints where a small floor penetration is desired. Recommended for use under x-ray
3	Poke-Through – Recessed 	Poke-through with recessed receptacles <ul style="list-style-type: none"> 7.25" diameter; 6" hole/device 	Completely flush installation ~ minimizes trip hazards. <ul style="list-style-type: none"> Easy/quick installation UL listed assembly Fire-rated Tamper-proof cover Recessed connections 6" device can support any 20A outlet configuration 	<ul style="list-style-type: none"> 6" hole in floor Floor X-ray required in order to avoid existing steel. Extra coring required to mount lip of the receptacle flush in terrazzo floor. 	<ul style="list-style-type: none"> Recommended at checkpoints where a large core drill will not impact the structural integrity of the floor. Recommended at checkpoints where a flush installation is desired. 6" device has smaller surface presentation than the modular surface box or the made-up surface box.
4	Poke-Through – Flush 	<ul style="list-style-type: none"> Poke-through with flush receptacles 7.5" diameter x 5/16" high; 3-4" hole/device, dependent on manufacturer 	<ul style="list-style-type: none"> Easy/quick installation UL listed assembly Fire-rated Wide variety of device combinations 	<ul style="list-style-type: none"> Floor X-ray required in order to avoid existing steel. Not flush ~ raised lip is a trip hazard. Electrical devices are proprietary. The plug is above floor level and can be knocked out. The floor cover is plastic, in some cases, therefore less durable in high traffic areas. 	<ul style="list-style-type: none"> Recommended only for equipment that does not require a twistlock or simplex receptacle. Recommended in low traffic areas, since these receptacles have nonmetallic covers that can break easily.
5	Made-up Surface Box 	Surface-mount cast box <ul style="list-style-type: none"> 4"W x 2"D x 2"H/ outlet; 7/8" hole/outlet 	<ul style="list-style-type: none"> 7/8" hole in floor 1/2" Rigid Galvanized Steel (RGS) floor penetration Inexpensive Easy to relocate and repair floor Can be reconfigured easily Limited structural impact to floor Supports any outlet configuration 	<ul style="list-style-type: none"> Not a UL listed assembly Not flush ~ trip hazard Plug is above floor level and can be knocked out. Not attractive Need separate penetrations for data and power. Need to include detail on drawings. Field assembly is required. 	<ul style="list-style-type: none"> Recommended at checkpoints where a small floor penetration is desired. Recommended for cutting costs. Recommended at existing checkpoints with floor penetration limitations.

Figure 4-8 Power/Data Device Distribution (Continued)

Item	Service Type	Description	Pro	Con	Recommendation
6	Ceiling or Floor-Supported Power Pole 	Floor to ceiling dual channel metallic raceway; 36" AFF floor-supported Wiremold Vista Point 5 Column	<ul style="list-style-type: none"> Inexpensive Easy to relocate and repair floor/ceiling Can be reconfigured easily Supports any outlet configuration 	<ul style="list-style-type: none"> Not attractive Obscures visibility across the checkpoint. Safety concern for high traffic areas Difficult to install at checkpoints with high ceilings. 	<ul style="list-style-type: none"> Ceiling-supported power poles recommended for slab-on-grade checkpoints where floor trenching is not desired. Floor-supported power poles recommended for AIT when there is passenger flow on both sides of the AIT.
7	Multiplex Surface Box 	Surface-mount cast box <ul style="list-style-type: none"> 8-3/4"W x 6-3/4"D x 3"H, (2) 1-5/8" hole/outlet 	<ul style="list-style-type: none"> 7/8" hole in floor 1/2" Rigid Galvanized Steel (RGS) floor penetration Inexpensive Easy to relocate and repair floor Can be reconfigured easily Limited structural impact to floor Supports any outlet configuration 	<ul style="list-style-type: none"> Not flush ~ trip hazard Floor X-ray required in order to avoid existing steel. Not attractive The plug is above floor level and can be knocked out. 	<ul style="list-style-type: none"> Recommended for slab on-grade checkpoints.
8	Flush, In-floor Box 	Cast-in-place multi-gang box with Brass/Aluminum cover <ul style="list-style-type: none"> 2"W x 4"D/outlet 	<ul style="list-style-type: none"> Completely flush installation Small surface presentation Blank cover plates can be used for inactivation. Supports any outlet configuration. Easy to retrofit in field if overall box can remain. 	<ul style="list-style-type: none"> 12" x 12" hole in floor Not flexible Very difficult to install in existing floors Difficult to match existing terrazzo floor Difficult to remove and repair floor Cover plate doors break off. Plug is above floor level and can be knocked out. Difficult to keep clean Structural evaluation is required for existing floors. 	<ul style="list-style-type: none"> Recommended for new terminals/checkpoints, or at checkpoints where the floor is being replaced.
9	Self-Supporting Truss 	Truss raceway support system	<ul style="list-style-type: none"> Self-supporting and freestanding Structurally strong Modular and flexible Re-useable components Easy, quick installation/removal No floor penetrations required. Provides support for power and data raceways in SSCPs where there is no available ceiling access and/or floor cutting/drilling is not permissible. 	<ul style="list-style-type: none"> Non-aesthetic; architectural treatment may be needed. Structural evaluation required Requires raceways for SSCP power/data outlets High cost 	<ul style="list-style-type: none"> Recommended for SSCP retrofits where there is no available ceiling access and/or floor cutting/drilling is not permissible.

4.4 POWER/DATA CONFIGURATIONS

Checkpoint equipment can be fed by a power/data device configured to support one or several pieces of equipment. As the device gets larger, more equipment can be supported. However, as the device gets larger, the floor core gets larger which often becomes a roadblock with the airport and/or the permit authority. When designing a checkpoint with any of the electrical distributions/devices described previously, the configuration of the device should be indicated on the drawings so that the contractor knows the combination of receptacles, data jacks, and connectors needed to support equipment located together. **Figure 4-9** lists the configuration letter, the components included, the quantity of components, the equipment supported and any additional remarks. These configuration letters are assigned to the devices shown on the power/data plans in the next section.

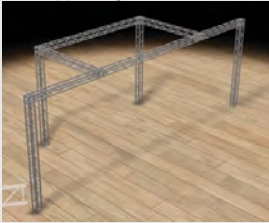
Figure 4-10 compares different types of devices and the corresponding quantity and floor core size required to achieve the same configuration. A physical example of the impacts of using different devices is graphically illustrated in **Figure 4-11**. The details show how additional devices may be needed in order to achieve the same configuration. Both figures represent how the airport or AHJ may be convinced to use the larger poke-through to support the most equipment in order to reduce the number of holes in the floor. However, they may request a structural analysis to evaluate any impacts before final approval is granted.

Figure 4-9 Outlet Configuration Schedule







CONFIGURATION	 L5-15R SIMPLEX TWIST LOCK	 L6-30R SIMPLEX TWIST LOCK	 5-20R SIMPLEX	 5-20R DUPLEX	 5-20R DUPLEX (PROPRI- ETARY)	 5-20R SPLIT- WIRED DUPLEX	 (6) RJ45/568B DATA JACKS	INTENDED USE	REMARKS
A	1					1	8	AT XRAY, WTMD, AIT	
B	1				1	1	10	AT XRAY, INFEED CONVEYOR, WTMD, AIT & PORTABLE ETD	
C	1		1				6	AT XRAY, WTMD	
D	1		1		1		6	AT XRAY, INFEED CONVEYOR, WTMD	
E						1	6	AT XRAY, AIT	
F					1	1	8	AT XRAY, INFEED CONVEYOR, AIT & PORTABLE ETD	
G			1				4	AT XRAY, OR AIT	
H						1	8	AT XRAY, INFEED	
K	1						2	WTMD	
L					1		2	TDC/CAT/STSO PODIUMS, PRIVATE SCREENING ROOMS	
M				2			6	MULTIPLE AIT WORKSTATIONS	
N					1		6-8	AVS/ETD/BLS-AVS	
P		1						IT CABINET	COORDINATE RECEPTACLE CONFIGURATION WITH TSA OIT
R	1			1			4	WTMD AND TDC PODIUM	

Figure 4-10 Device Configuration Comparison

CONFIGURATION	Figure 4-7 / 1 RECESSED FLUSH POKE-THROUGH (QTY.) & SIZE	Figure 4-7 / 2 POKE-THROUGH FLUSH (QTY.) & SIZE	Figure 4-7 / 3 MODULAR SURFACE BOX (QTY.) & SIZE	Figure 4-7 / 4 SURFACE MOUNTED MADE-UP SURFACE POX (TOMBSTONE) BOX (QTY.) & SIZE	Figure 4-7 / 5 POWER POLE (QTY.)	Figure 4-8 / 6, CASH-IN-PLACE FLUSH FLOOR BOX - 2" X 4" EA. (QTY.)
A				(2) 7/8"	(1) Pole	(4)
B		(3) 3"-4"	(2) 3"	(3) 7/8"		
C				(2) 7/8"		
D				(3) 7/8"		
E						
F						
G						
H	(1) 6"	(1) 3"-4"	(1) 3"		(1) Pole	(2)
K						
L						
M				(3) 7/8"	(1) Pole	(4)
N	(1) 6"					(2)
P		(2) 3"-4"	(2) 3"			(4)
R						
S						

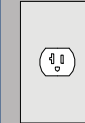
Figure 4-11 Device Comparison

CONFIGURATION "G" - (1) 7-1/2-INCH FLUSH

Poke-Throughs

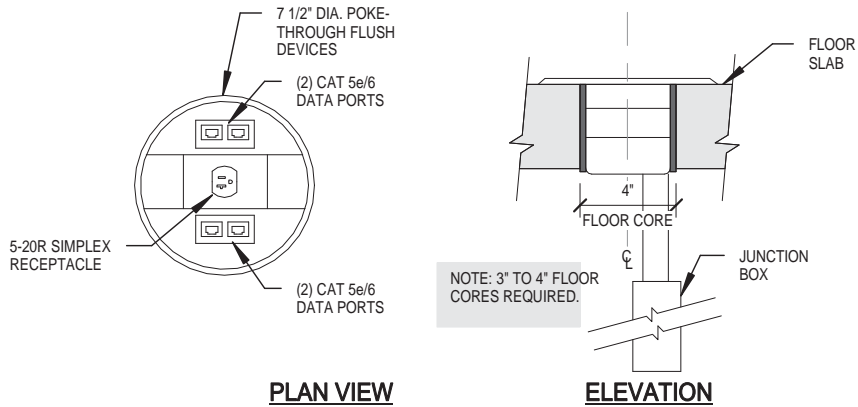

CONFIGURATION "G" - (1) FLOOR-TO-CEILING RACEWAY

Power Pole

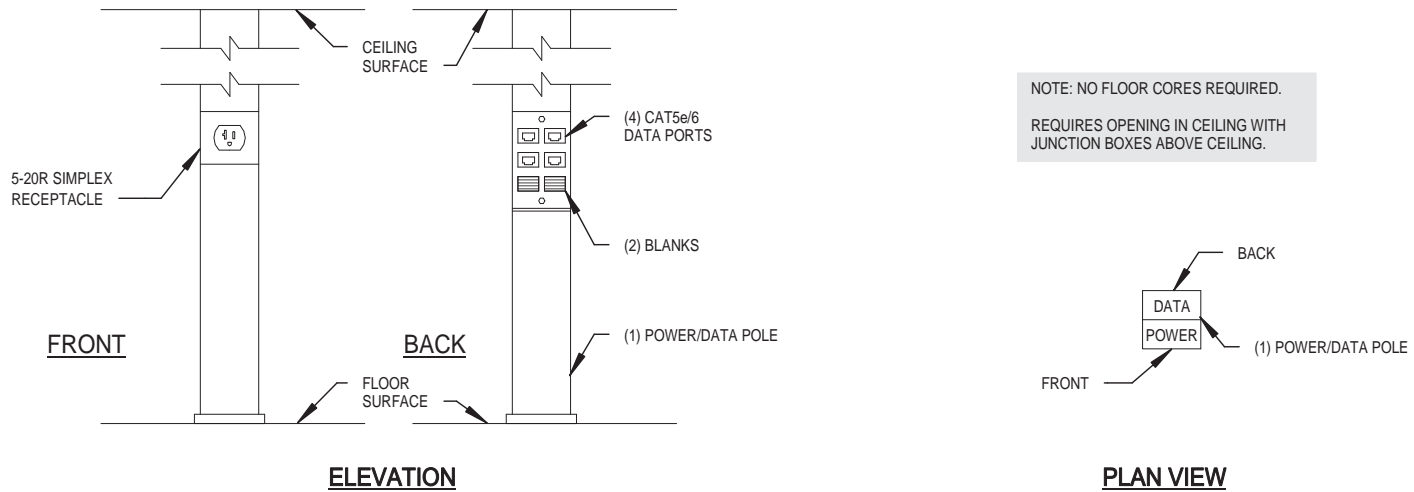
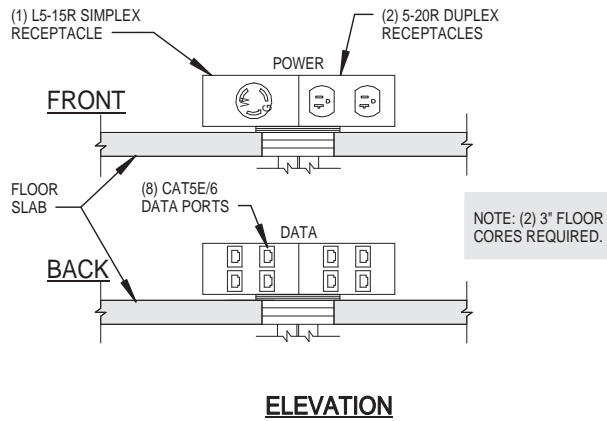

Figure 4-12 Device Comparison (Continued)

Surface Boxes

CONFIGURATION "A" - (2) MODULAR



CONFIGURATION "A" - (2) MADE-UP

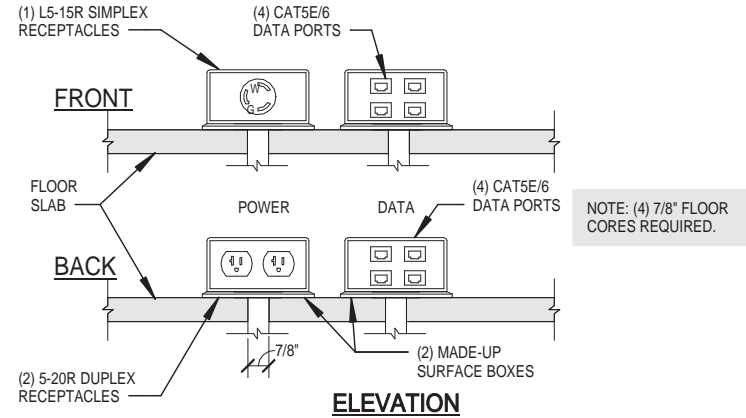

CONFIGURATION "A" - (1) MULTIPLEX

Surface Boxes

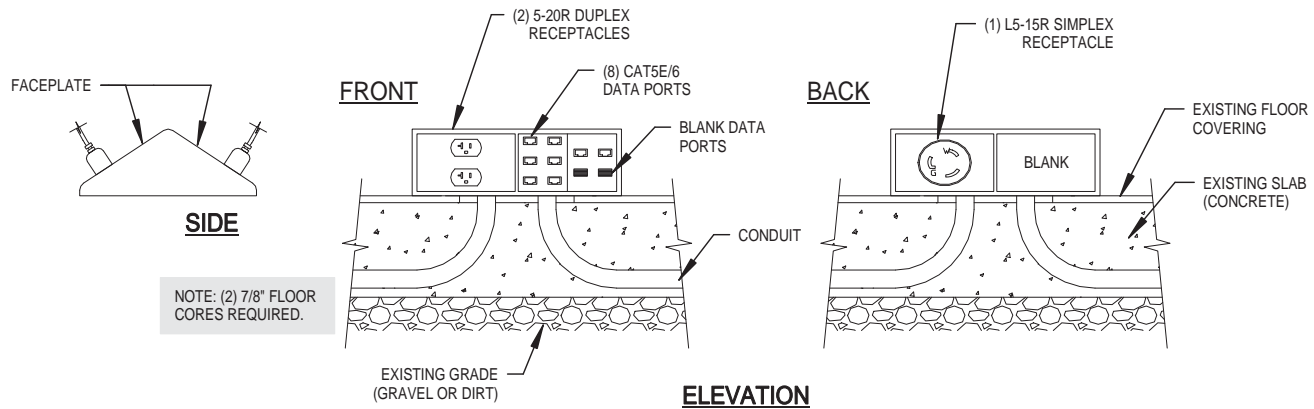
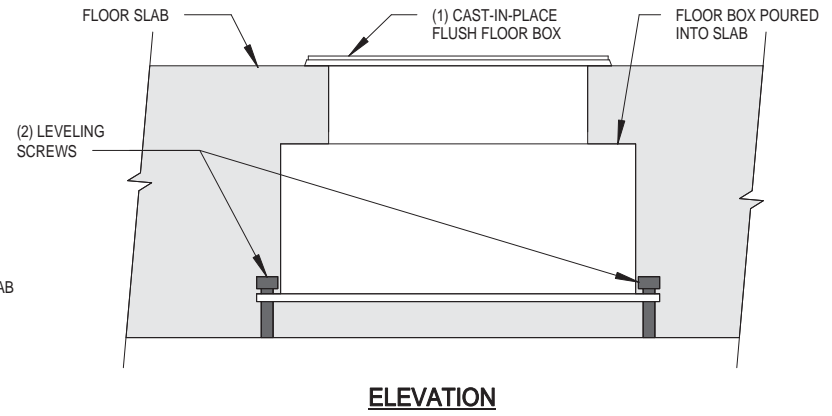
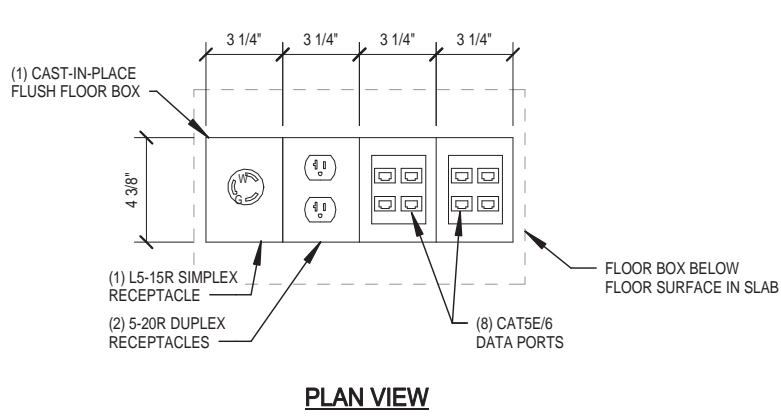

Figure 4-13 Device Comparison (Continued)

CONFIGURATION "A" - (1) FLUSH/CAST-IN-PLACE

In-Floor Boxes



4.5 POWER/DATA PLANS

Figure 4-14 shows the recommended power/data layout for SSCP Standard Arrangement. These graphics show the approximate locations and configurations of various devices that can be used to support multiple TSE. Recessed, flush, and surface devices are represented by the purple hexagon. Most of these devices are concealed under equipment with enough clearance for the height of the device and the plug. The truly flush recessed device is shown at the required three locations mentioned previously and is represented by the orange symbol. Power poles are represented by a red square or a blue oval. Only one type of distribution should be chosen. The power poles should only be designed when the checkpoint is slab-on-grade or the preferred distribution is via power pole. The 36" floor-supported power pole should only be used for the AIT when there is passenger flow on both sides of the AIT from an ADA Gate, WTMD, or additional AIT when a ceiling-supported power pole is not possible or feasible. Every attempt should be made to locate receptacles under the lanes to feed the lanes and all infield equipment; however, this is not always possible. In some cases, the L3 AIT can be rotated 180 degrees in order to locate the electrical control leg adjacent to a receptacle located under the infeed or the outfeed of the AT unit.

The SSCP Standard Arrangement shows the power/data receptacles either under the infeed queuing conveyor or under the HSC depending on where the infield equipment is located. Even though the WTMD can only be powered from the lane with a barrier between them, a twistlock receptacle must be provided in the outlet configuration for every lane so that TSA has the flexibility to switch the ADA gate or AIT and power the WTMD from the other leg.

Care needs to be given to the location of recessed, flush, or surface devices so that they are able to support future arrangements.

Figure 4-14 SSCP Standard Arrangement Power/Data Plan

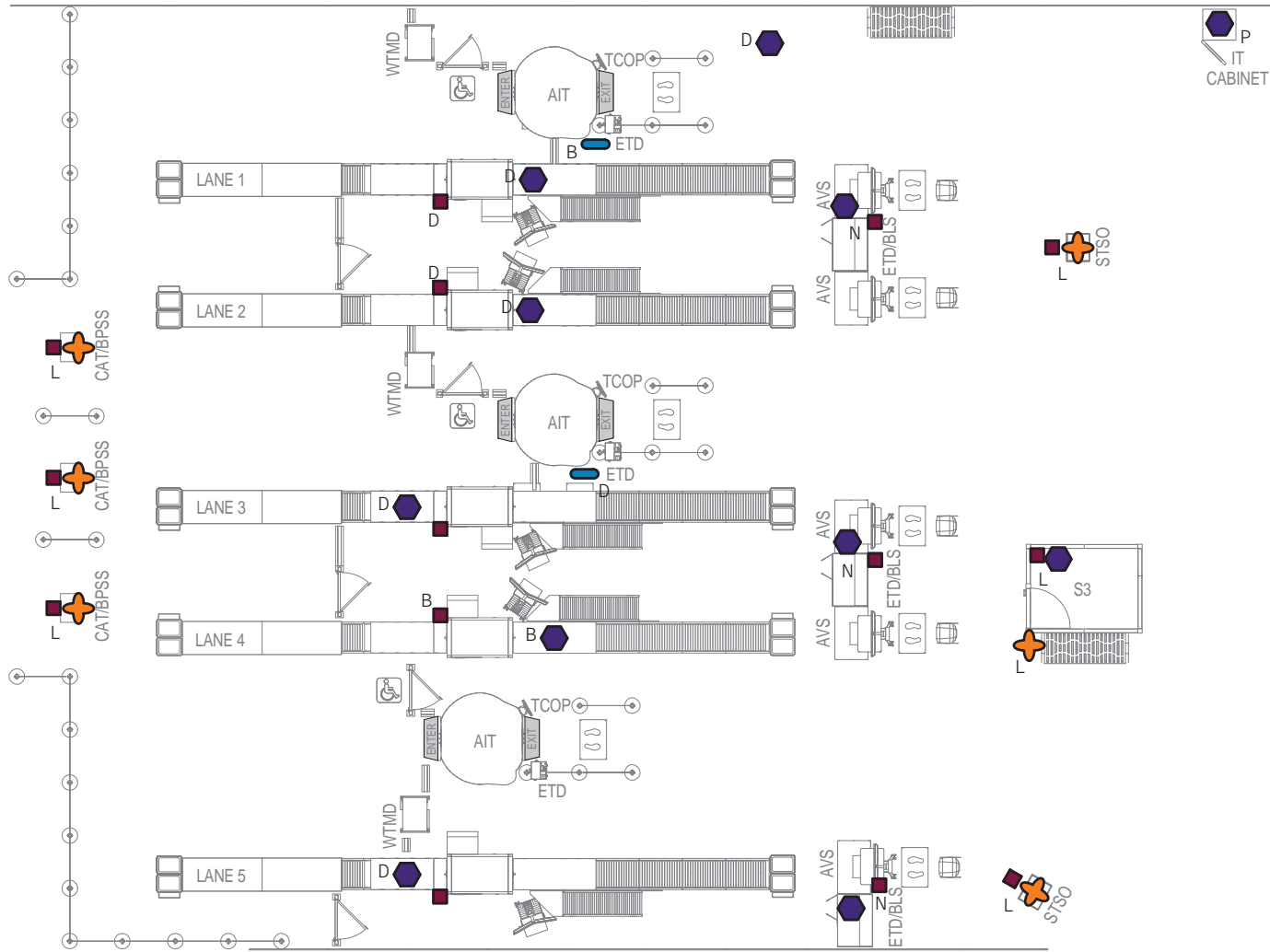

PLAN VIEW

LEGEND

- A** RECESSED, FLUSH, OR SURFACE DEVICE
- A** TRULY FLUSH RECESSED DEVICE
- A** POWER POLE
- A** POWER POLE; 36" FLOOR-SUPPORTED POWER POLE WHERE CEILING-SUPPORTED POWER POLE IS NOT FEASIBLE
- A** WALL-MOUNTED, RECESSED, FLUSH, SURFACE, OR POWER POLE DEVICE

NOTES

1. LETTER SUBSCRIPT DENOTES CONFIGURATION IN FIGURE 4-10.
2. REFER TO SECTION 2 FOR SPECIFIC ELECTRICAL DEVICE LOCATION.
3. ELECTRICAL DEVICES ARE NOT SHOWN TO SCALE.
4. CHOOSE EITHER FLOOR OR POWER POLE DEVICE DISTRIBUTION.

4.6 CCTV REQUIREMENTS

Cameras are not mandatory at an SSCP, but they do increase the level of security. Cameras deter theft, reduce claims, provide data in resolving issues, and capture visual records of suspicious activity. They are particularly helpful at unmanned or closed checkpoints. The number of cameras to add will vary depending on the size of the checkpoint, obstructions within the checkpoint, lighting, and the quality of the CCTV system. A sufficient number of cameras should be added to cover each lane, all secondary screening areas, and co-located exit lanes. **Figure 4-15** indicates the recommended CCTV coverage areas of the SSCP. Cameras should not intrude on passenger privacy by locating them in Private Screening Rooms. Cameras should be positioned to show the front view of a person's face and any other identifying characteristics.

TSA prefers CCTV design as an extension of an existing facility security system within the airport. When CCTV is part of an extended system, the equipment should match the existing hardware in order to minimize maintenance costs and provide operator familiarity. Storage and retrieval of video footage will need to be determined on a site-by-site basis. The existing facility security system should provide a minimum of 30 days of recording. Local TSA and law enforcement should be able to access the system at or near the checkpoint. The security system should have a means to maintain an accurate system time. When a CCTV system exists, it is shared between the airport, law enforcement, and local TSA. Sometimes construction documents by the CCTV Owner's designer or some other designated firm are required to indicate the CCTV system scope of work required to relocate or add cameras to support the checkpoint reconfiguration or additional new equipment. These documents are typically full sized and consist of the following.

- CCTV & Electrical System Abbreviations, Symbols and General Notes
- CCTV Camera Mounting Details

- CCTV System Demolition indicating components to remain or be removed. Also includes a CCTV camera schedule indicating the focus, aim, mounting, and applicable remarks for each existing CCTV camera.
- New CCTV System Installation indicating components to remain or to be provided as new. Also includes CCTV camera schedule indicating the focus, aim, mounting, relocation, disposition, and type for each new CCTV camera.

These drawings are not typically provided by TSA, but they are part of a checkpoint construction contract. TSA provides the operational requirements from the local FSD that provides enough detail for the system to meet the needs of the program. A typical operational requirement is "provide a view of people entering and exiting a WTMD with enough detail to recognize the person and any object they may be carrying". Specific questions on the generation of requirements should be directed to the ASP program at: ost_asp_video_surveillance@tsa.dhs.gov.

Refer to the TSA Recommended Security Guidelines for Airport Planning, Design and Construction, Part III for additional information. For CCTV systems that are extensions of existing building systems, a cost reimbursement program may be available through OSC.

Typical camera coverage is shown in Figure 4-15. All camera coverage details need to be discussed with TSA HQ; specific coverage requirements cannot be detailed in the CDG.

Figure 4-15 Recommended CCTV Coverage

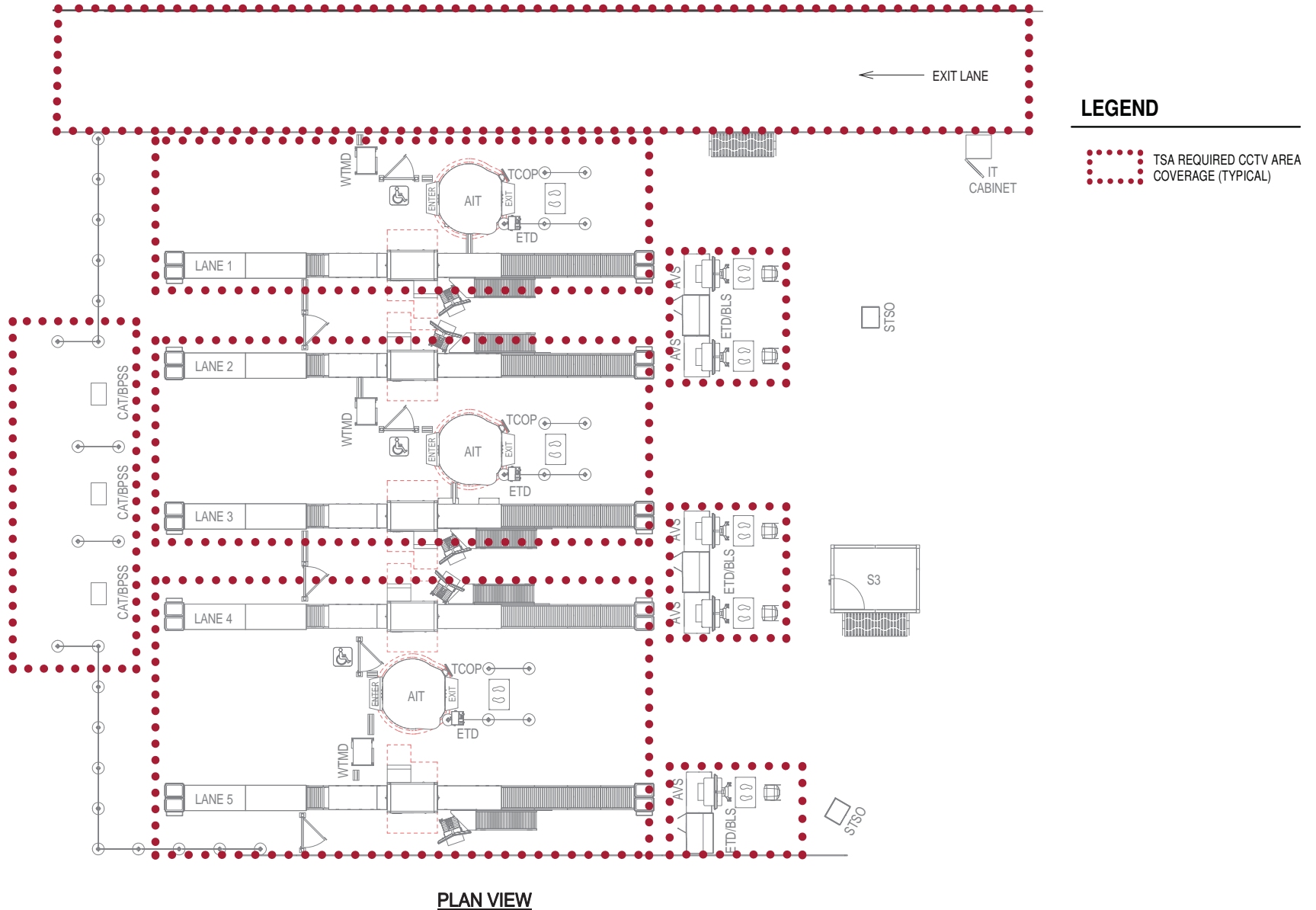

LEGEND

- TSA REQUIRED CCTV AREA COVERAGE (TYPICAL)

4.7 LIGHTING REQUIREMENTS

Lighting requirements for a new checkpoint should meet national codes and ideally meet the minimum luminance level of 30 foot-candles (fc) as defined by ANSI/IESNA RP-104. In some cases this requirement may be higher when the minimum is set by local building codes. TSA does not provide overhead lighting. The airport is expected to provide sufficient overhead lighting to support the screening functions at the checkpoint. On occasion, TSA may fund overhead lighting modifications when the existing overhead light fixtures need to be relocated or added due to a significant checkpoint reconfiguration or a conflict with equipment. This should be negotiated during the early planning stages of the checkpoint design.

TSA HQ will provide task lighting for secondary screening functions, if needed. Local TSA should submit a ReMAG request for TSA HQ to evaluate and determine if the task lighting can be provided from the OSC Hazard Safety Mitigation ETD Task Lighting Material List. Depending on the request, local TSA may be asked to purchase task lighting from a local hardware store with their p-card. Before task lighting is procured, local TSA should determine that there are available receptacles to support the task lighting.

Additional lighting may be required for a CCTV system at the checkpoint. This lighting should be provided by the group funding and maintaining the CCTV system. Refer to Section 4.6 regarding additional information on CCTV.

This page is intentionally left blank.

5.0 SAFETY

SSCPs must screen passengers and their carry-on baggage without compromising the safety of either the passengers or the TSOs conducting the screening. Safety requirements and safety-related considerations must be built into the SSCP design from the beginning and should be treated as an integral part of the design process. The standard checkpoint layouts in this document are intended to provide good starting points, but safety Subject Matter Experts (SMEs) should be included in every phase of the design to provide input on concept plans and/or construction drawing packages.

Particular safety issues related to equipment or layouts that are likely to arise in the course of SSCP design are discussed within the appropriate sections within this document. However, this document is not intended to provide an exhaustive list of such issues. Safety experts from each discipline should review all available sources of information, such as best practices, Technical Notes, Job Aids, OSHA/OSHE requirements, and TSO injury data to ensure that the most current knowledge is incorporated into each SSCP design.

The SSCP equipment, including PSRs, must meet all local code requirements and/or ASHRAE standards for heating, ventilation, and air conditioning. When checkpoints are located outside, the AHJ should be consulted. Indoor air temperature and relative humidity levels should be maintained at a comfortable level based on the occupancy, size, and exposure of the SSCP. Air quality should be monitored at the checkpoint to prevent the build-up of carbon dioxide from human respiration and to minimize odors. As checkpoints are designed and reconfigured, the Airport Authority may need to rebalance the airport HVAC system and/or evaluate and update the HVAC preventative maintenance procedures.

This page is intentionally left blank.

6.0 APPENDIX A - SSCP TERMINOLOGY

Acronym	Definition
1-D	One Dimensional
1-to-1	1 TRX or AT for every WTMD 1 AT for every AIT
2-D	Two Dimensional
2-to-1	2 TRX or AT for every WTMD 2 AT for every AIT
2-to-2	2 AT for 2 AIT
3-D	Three Dimensional
A	Amps
A&E	Architectural & Engineering
ABC	Alarm Bag Cutout
ADA	Americans with Disabilities Act
AFF	Above Finished Floor
AFSD	Assistant Federal Security Director
AHJ	Authority Having Jurisdiction
AIT	Advanced Imaging Technology
ANSI	American National Standards Institute
ARW	Alarm Resolution Workstation for Reveal AutoEDS
ASHRAE	American Society of Heating, Refrigerating and Air-Conditioning Engineers
ASP	Advanced Surveillance Program

Acronym	Definition
AT	Advanced Technology X-Ray
AT1	First Deployment of AT
AT2	Second Deployment of AT; includes AVS
ATR	Automatic Target Recognition
AutoEDS	Automatic Explosive Detection System
AVS	Alternate Viewing Station
AWT	Automated Wait Time
BLS	Bottle Liquids Scanner
BRS	Bin Return System
BVS	Baggage Viewing Station for AutoEDS
CAT/BPSS	Credential Authentication Technology/Boarding Pass Scanning System
Cat5 / Cat5e / Cat6	Category 5 data cable / Category 5e data cable / Category 6 data cable
CBIS	Checked Baggage Inspection System
CCTV	Closed Circuit Television
CDG	Checkpoint Design Guide
CL	Centerline
CPI	Cast & Prosthesis Imager
DOT	Department of Transportation

Acronym	Definition
DHS	Department of Homeland Security
DSS	Diamond Self Select
EDS	Explosive Detection System
EMD	Enhanced Metal Detector
eTAS	Electronic Time, Attendance, and Scheduling
ETD	Explosive Trace Detection
fc	Foot-candles; unit of luminance or light intensity
FDRS	Field Data Recording System
FIS	Federal Inspection Service
FRM	Field Regional Manager
FSD	Federal Security Director
FY	Fiscal Year
Hi-SOC	High Speed Operational Connectivity
HSC	High Speed Conveyor
HVAC	Heating, Ventilation and Air Conditioning
IDF	Intermediate Distribution Frame
IEEE	Institute of Electrical & Electronics Engineers
IESNA	Illuminating Engineering Society of North America
IMAC	Install, Move, Add, or Change
IO	Image Operator
IT	Information Technology
J3	Passenger Containment Kit/Holding Station

Acronym	Definition
LAGs	Liquids, Aerosols, & Gels
LAN	Local Area Network
LCU	Lane Control Unit for the L3 ProVision AIT
LEO	Law Enforcement Officer
LH	Left Hand
MAX	Maximum
MCB	Main Circuit Breaker
MDF	Main Distribution Frame
MDR	Manual Diverter Roller
MIN	Minimum
N3	Passenger Inspection Kit/Holding/Inspection Station
NEC	National Electric Code
NEMA	National Electrical Manufacturers Association
O&D	Origin and Destination
OEM	Original Equipment Manufacturer
OIT	Office of Information Technology
OOB	Out of Band
OSC	Office of Security Capabilities
OSHA	Occupational Safety & Health Administration
OSHE	Occupational Safety, Health, & Environment
PAX	Passengers
POC	Point of Contact

Acronym	Definition
POE	Power Over Ethernet
POR	Program of Requirements
psf	Pounds per Square Foot
PSP	Passenger Screening Program
PSR	Private Screening Room
PWD	Passengers with Disabilities
RDM	Regional Deployment Manager
ReMAG	Requirements Management Advisory Group
RF	Radio Frequency
RGS	Rigid Galvanized Steel
RH	Right Hand
S3	6'W x 8'L x 8'H KI glass room with 3' door on short side. Used for Private Screening Room.
S3-A	8'W x 6'L x 8'H KI glass room with 3' door on long side. Used for Private Screening Room.
SF	Square Foot
SME	Subject Matter Expert
SO	Scanning Operator
SOW	Scope of Work
SSCP	Security Screening Checkpoint
SSI	Security Sensitive Information
STIP	Security Technology Integrated Program
STSO	Supervisory Transportation Security Officer
T3	6'W x 8'L x 6'H KI glass room with 3' door on short side.

Acronym	Definition
T3-A	8'W x 6'L x 6'H KI glass room with 3' door on long side. Used for private screening only if ceiling height is less than or equal to 8'-6".
TCOP	Touch Control Operator Panel
TDC	Travel Document Checker
TIP	Threat Image Projection
TLC	TSA Logistics Center
TRX	TIP-Ready X-Ray
TSA	Transportation Security Administration
TSA HQ	Transportation Security Administration - Headquarters
TSAPre [✓] ™	Transportation Security Administration PreCheck
TSE	Technical Security Equipment
TSO	Transportation Security Officer
UPS	Uninterruptible Power Supply
UTP	Unshielded Twisted Pair
V	Volts
VIPR	Visible Intermodal Prevention & Response
WAP	Wireless Access Point
WTMD	Walk Through Metal Detector

This page is intentionally left blank.

7.0 *APPENDIX B - CHECKLIST*

The following items have been identified as common oversights during checkpoint design. All test fits and drawings should be carefully reviewed for the following issues before submission. Please contact your OSC contact for additional guidance and review.

7.1 QC PLAN CHECKLIST

- A barrier should be positioned adjacent to the WTMD.
- A 1'-0" barrier should be positioned adjacent to the ADA gate/ AIT positions.
- The WTMD should be set 1'-6" deeper than the infeed conveyor to avoid passenger backflow after bag placement.
- Ensure that the ADA gate has proper entrance and exit clearances. At parallel lanes, the ADA gate should be close to the WTMD. The trailing edge of the ADA gate "plate" should align with the entrance ramp of the AIT.
- There should be two wanding mats located at the AIT and one wanding mat per lane near the ETD table. Wanding areas should use stanchions in lieu of glass unless the existing glass is to remain.
- The AVS/ETD/BLS should be centered on the TSA aisle.
- Unless directed otherwise, the exit of the AIT cannot be past the exit of the HSC.
- The AVS should be located closer to the extension roller than the ETD/BLS.
- All TSA access gates need to swing toward TSA and not toward passenger divest.
- The AVS should face toward the TSA work aisle.
- Minimum dimensions for equipment follow:
 - » Back to back operators - roller to roller or MDR to MDR or MDR to roller; bump out to bump out or bump out to main body; lane stager (leading edge of one x-ray to the leading edge of the other).
 - » Single lane to wall (operator's side) - main body or bump out to wall; roller to wall or MDR to wall.
 - » Single lane to wall (passenger side) - main body or bump to wall; WTMD or AIT to wall (space between); WTMD to KI glass; between WTMD and x-ray.
- » Two lane set (passenger side) - x-ray to AIT (both sides); WTMD to x-ray; roller to roller; WTMD to AIT entrance.
- » General - equipment to column; end of roller to leading edge of the AVS/ETD/BLS; trailing edge of AVS/ETD/BLS to KI glass wall, wall, or column; TDC and STSO podium reference points to tables or bin carts and any other fixed asset for reference.
- » Roller to wall.
- » Main body to main body.
- » Roller to roller.
- » AIT to AT2.
- » Position of AVS/ETD/BLS equipment.
- » Centerline of AVS in X and Y directions, from x-ray or other firm reference point.
- When passenger flow is on both sides of the AIT, use a 36" power pole instead of a floor receptacle.

This page is intentionally left blank.

This page is intentionally left blank.

8.0 APPENDIX C - STANDARD EQUIPMENT DIMENSIONAL CRITERIA

The intent of the section is to illustrate multiple checkpoint layouts with different manufacturers' equipment. The following figures represent the minimum dimensional requirements for passengers and screeners operating an effective checkpoint. This should be used as a guide when designing not only one or two lane checkpoints, but also the placement of equipment for multiple lanes. There are a wide variety of possibilities and all may not be shown in this section.

Rapiscan AT X-rays (RATs), Smiths AT X-rays (SATs) and L3 AT X-rays (LATs) can be installed with the different bump out configurations in relation to other checkpoint equipment, specifically the AIT and WTMD. RATs and SATs have the capability to have both left and right hand bump outs, LATs are only left hand bump out configurations.

The figures each have a naming convention that describes; first the model of the AT X-ray, second the model of the AIT, and third a numbering system. For example: RAT.LAIT.1.1 refers to a Rapiscan AT X-ray with an L3 AIT; SAT.RAIT.1.1 refers to a Smiths AT X-ray with a Rapiscan AIT.

8.1 RAPISCAN AT X-RAY LAYOUTS

Figure 8-1 Single Lane Rapiscan AT Bump In Layout

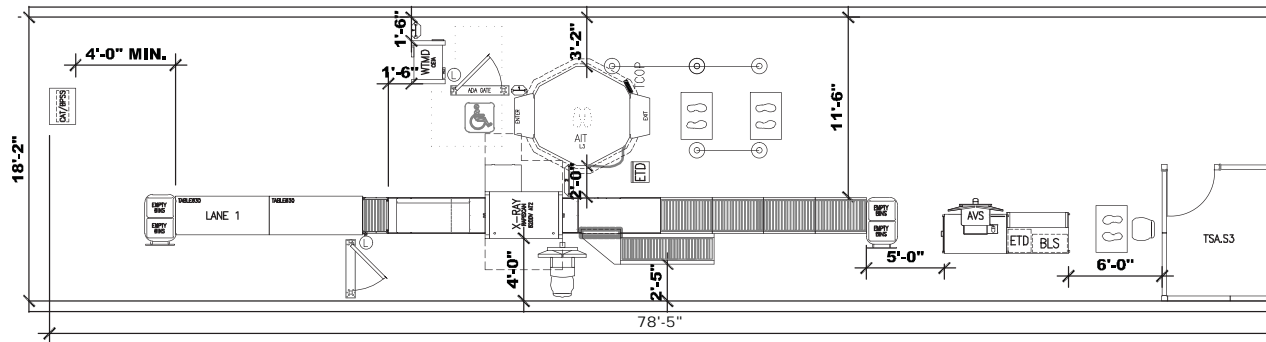

RAT.LAIT.1.1
Not To Scale

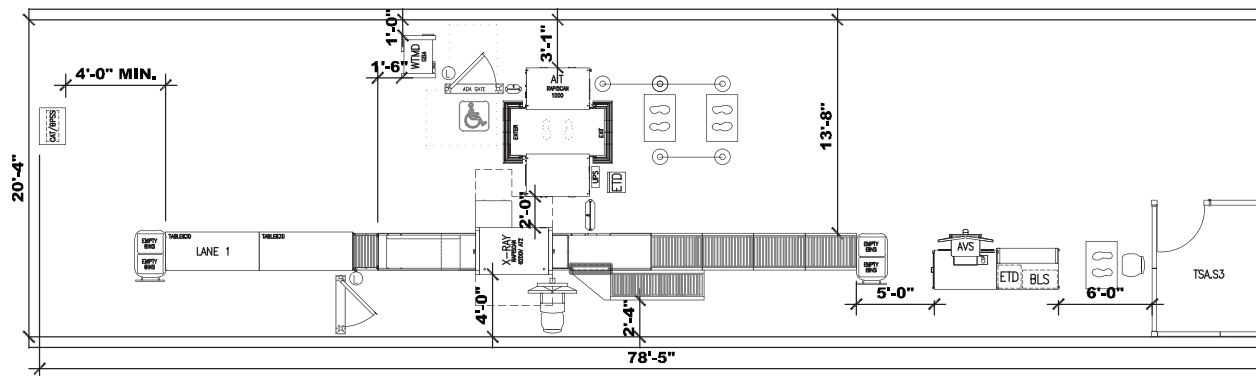

RAT.RAIT.1.1
Not To Scale

Figure 8-2 Single Lane Rapiscan AT Bump Out Layout

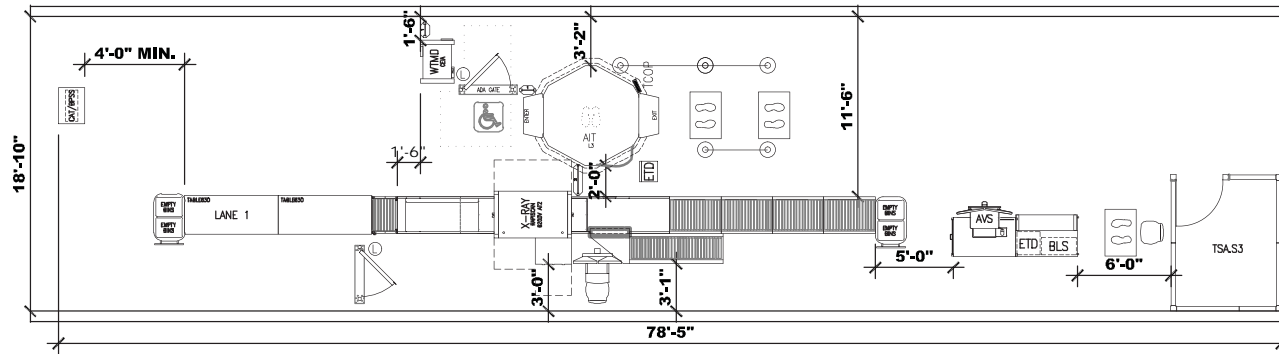

RAT.LAIT.1.2
Not To Scale

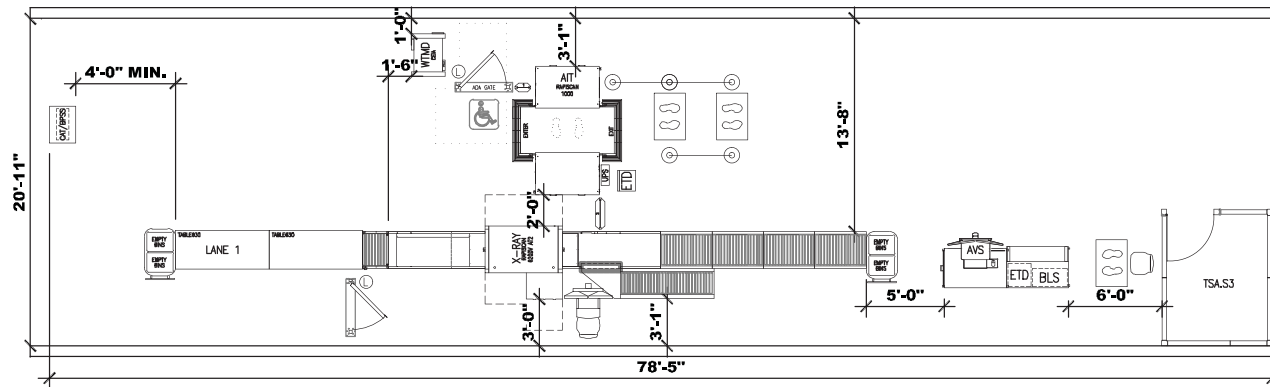

RAT.RAIT.1.2
Not To Scale

Figure 8-3 Two Lane Rapiscan AT Bump In/Bump In Layout

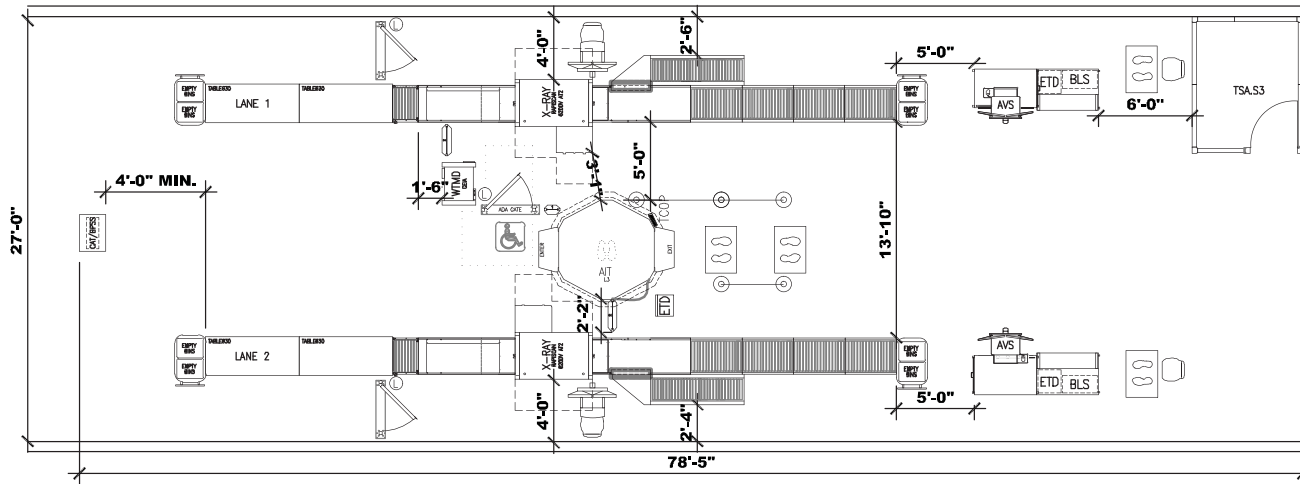

RAT.LAIT.2.1
Not To Scale

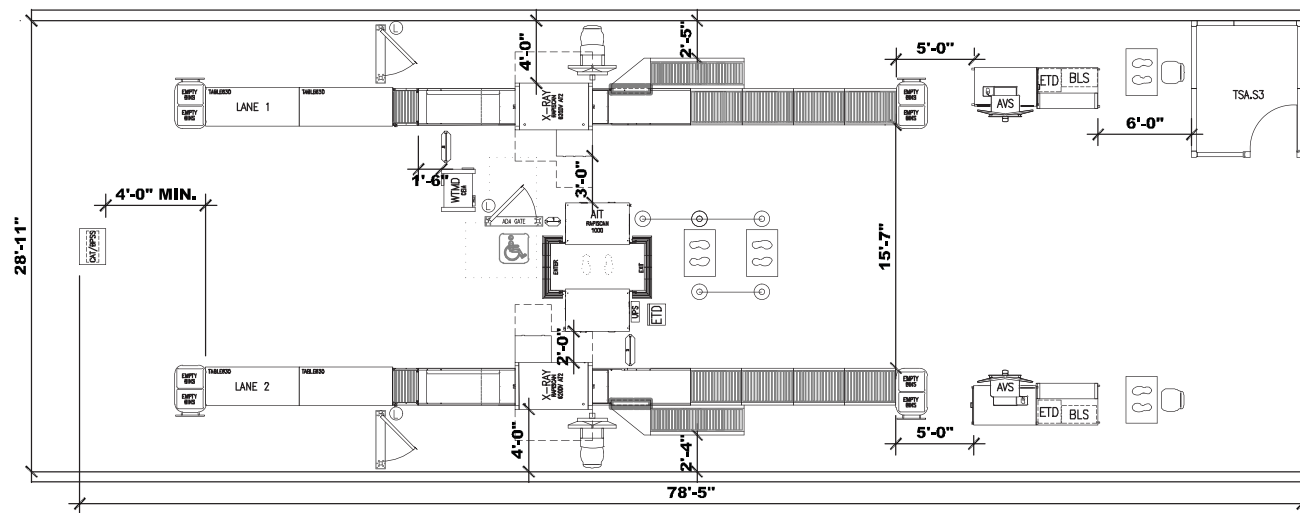

RAT.RAIT.2.1
Not To Scale

Figure 8-4 Two Lane Rapiscan AT Bump Out/Bump Out Layout

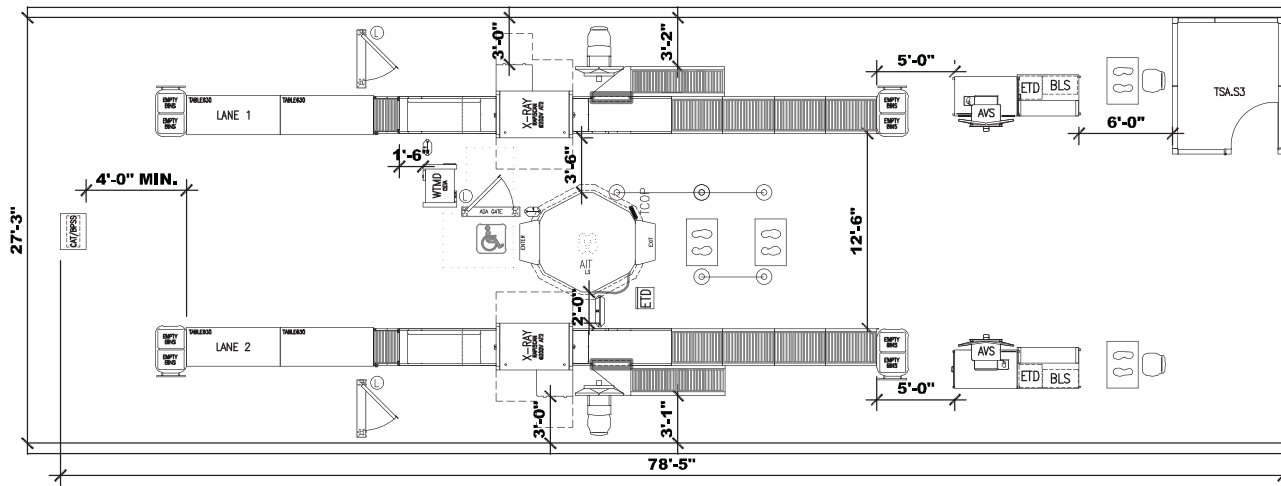

RAT.LAIT.2.2
Not To Scale

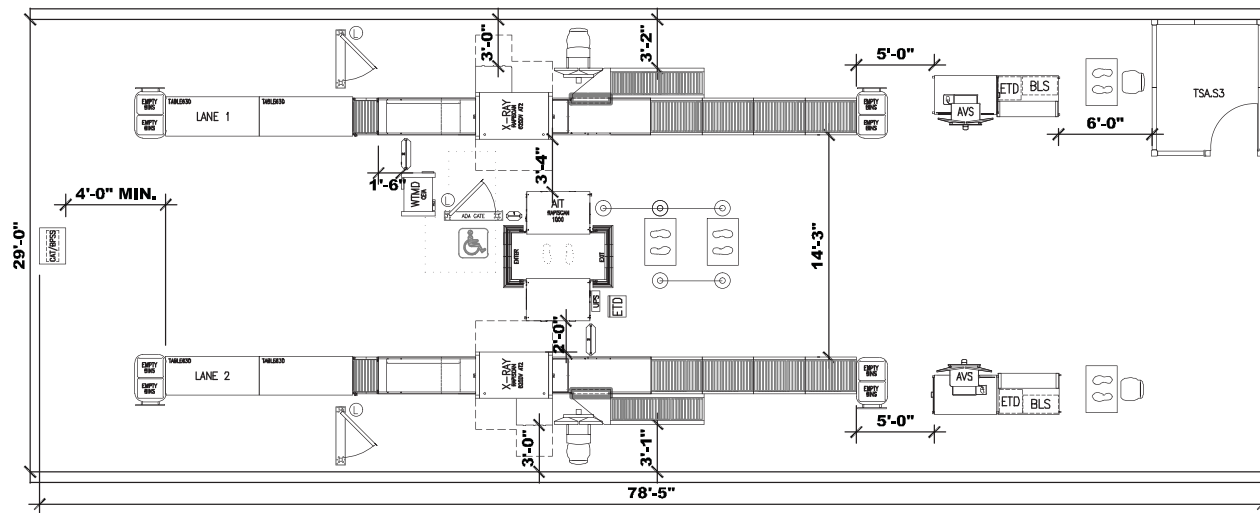

RAT.RAIT.2.2
Not To Scale

Figure 8-5 Two Lane Rapiscan AT Bump In/Bump Out Layout

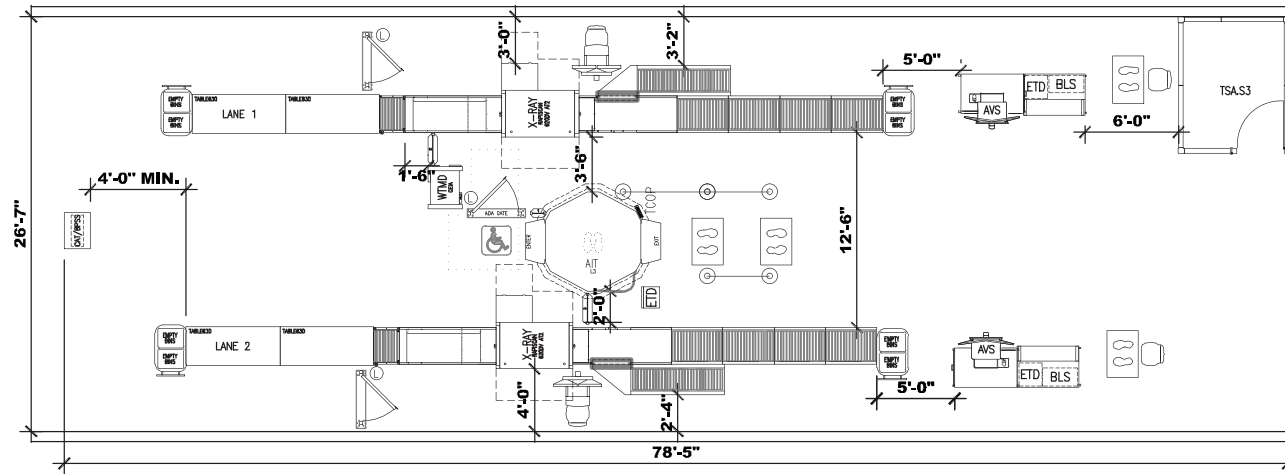

RAT.LAIT.2.3
Not To Scale

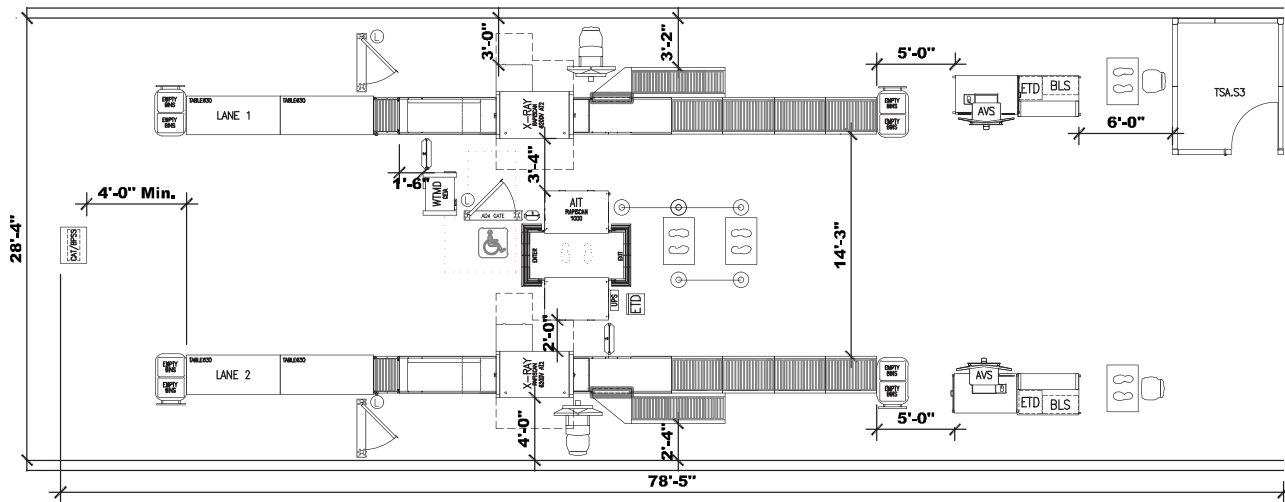

RAT.RAIT.2.3
Not To Scale

Figure 8-6 Two Lane Rapiscan AT Bump In/Bump In Center AIT Layout

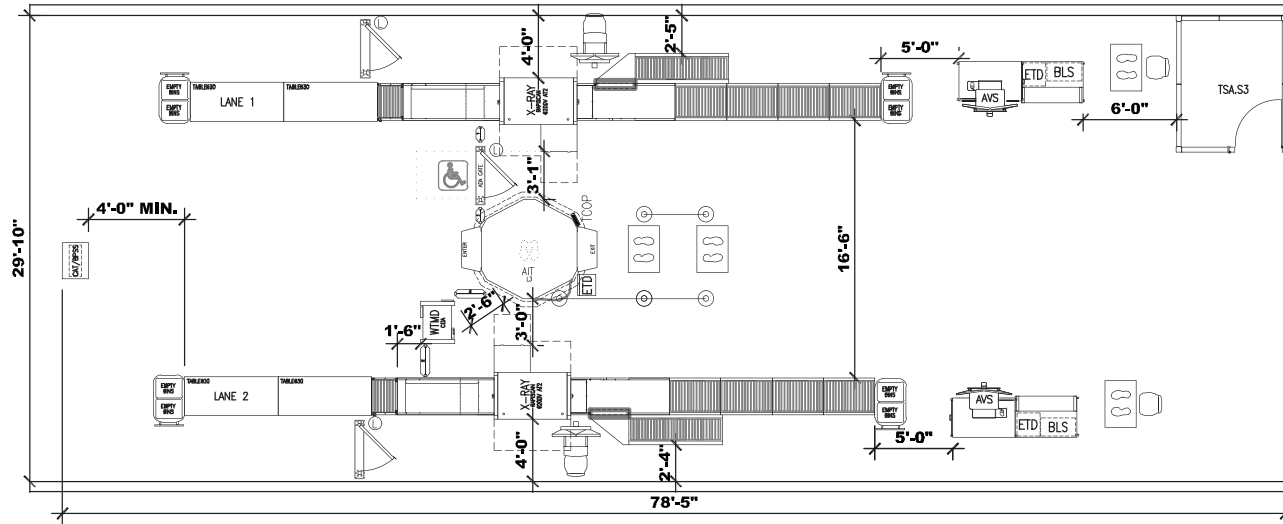

RAT.LAIT.3.1
Not To Scale

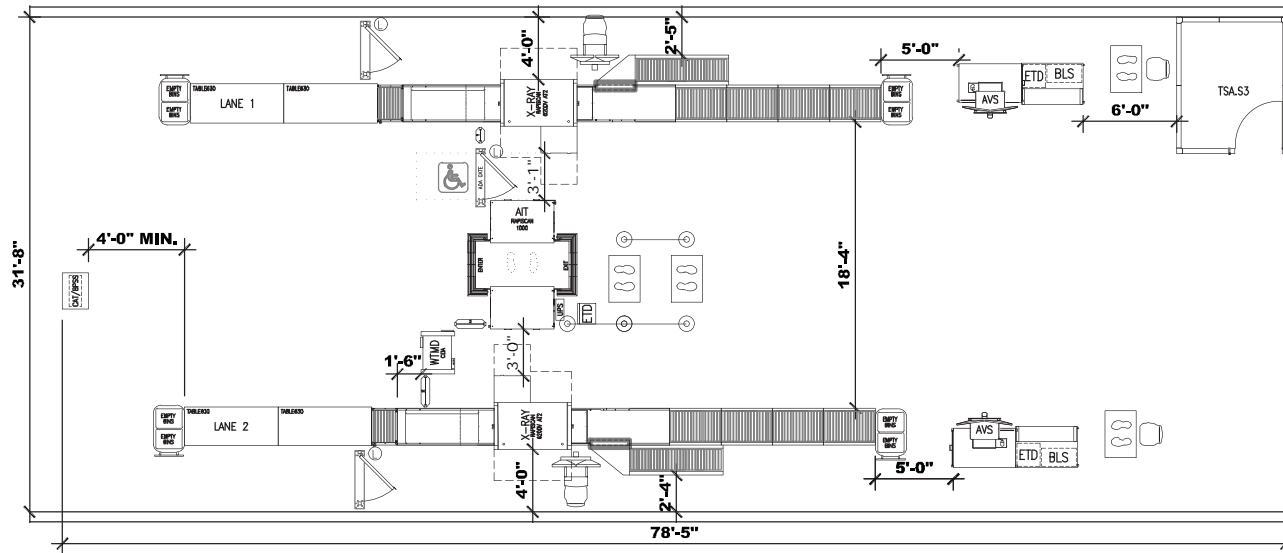

RAT.RAIT.3.1
Not To Scale

Figure 8-7 Two Lane Rapiscan AT Bump Out/Bump Out Center AIT Layout

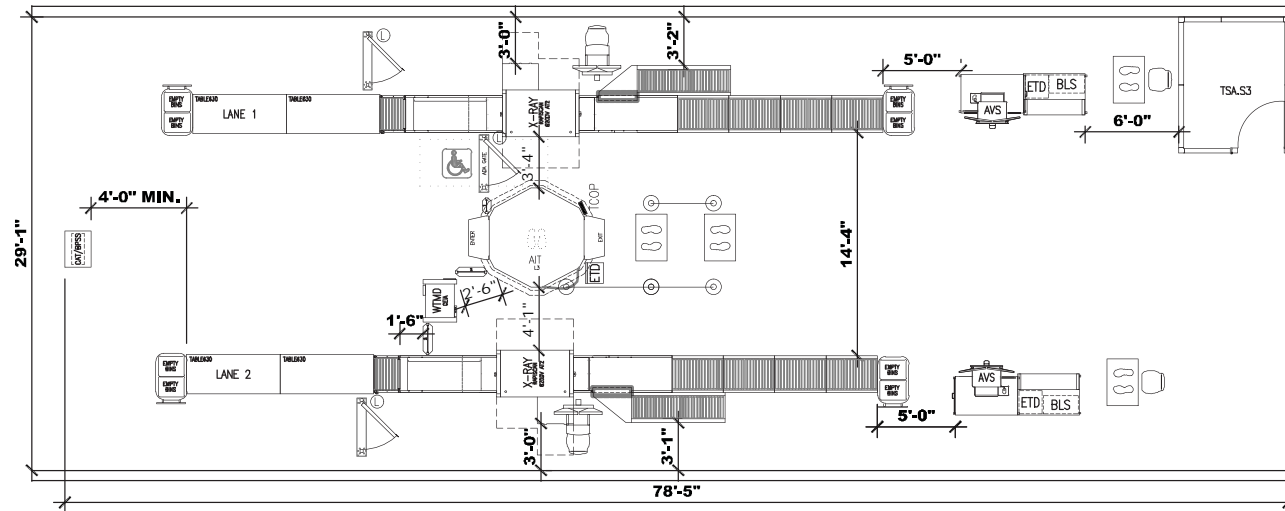

RAT.LAIT.3.2
Not To Scale

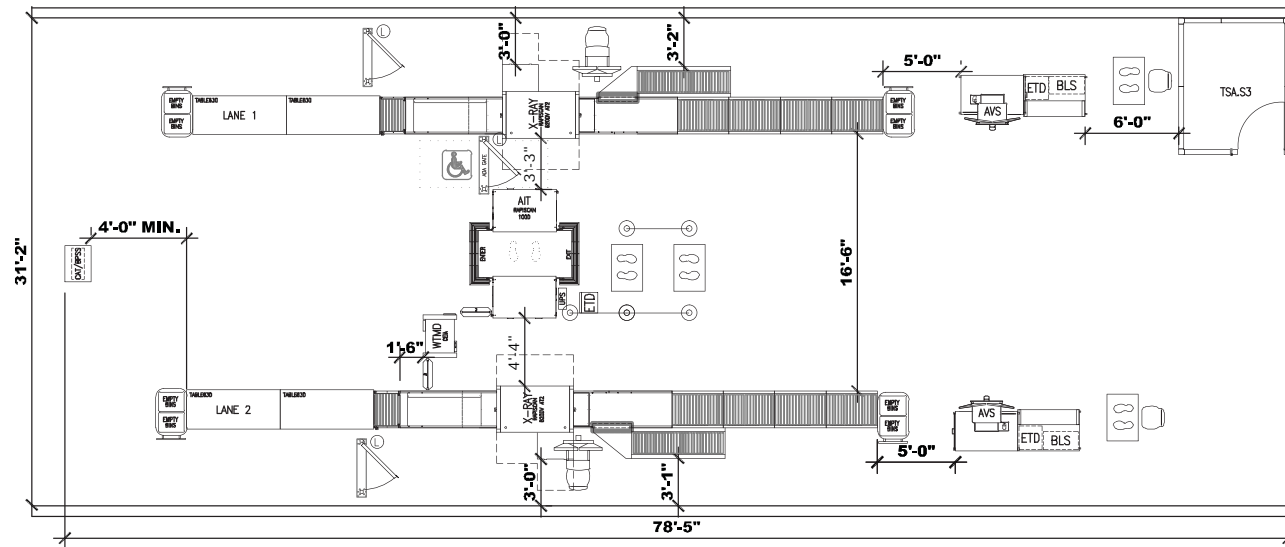

RAT.RAIT.3.2
Not To Scale

Figure 8-8 Two Lane Rapiscan AT Bump In/Bump Out Center AIT Layout

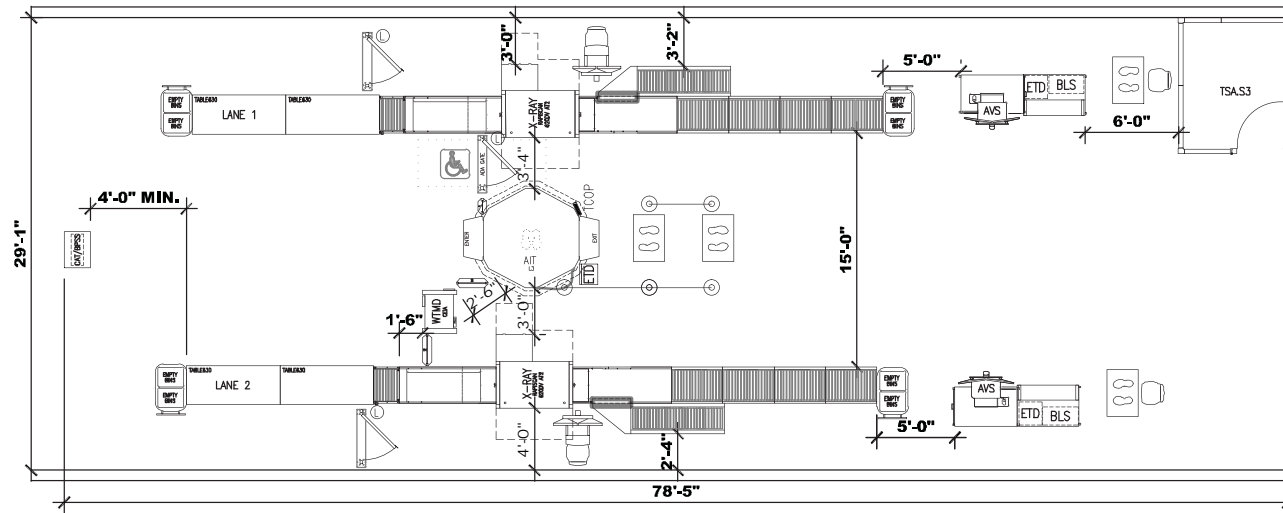

RAT.LAIT.3.3
Not To Scale

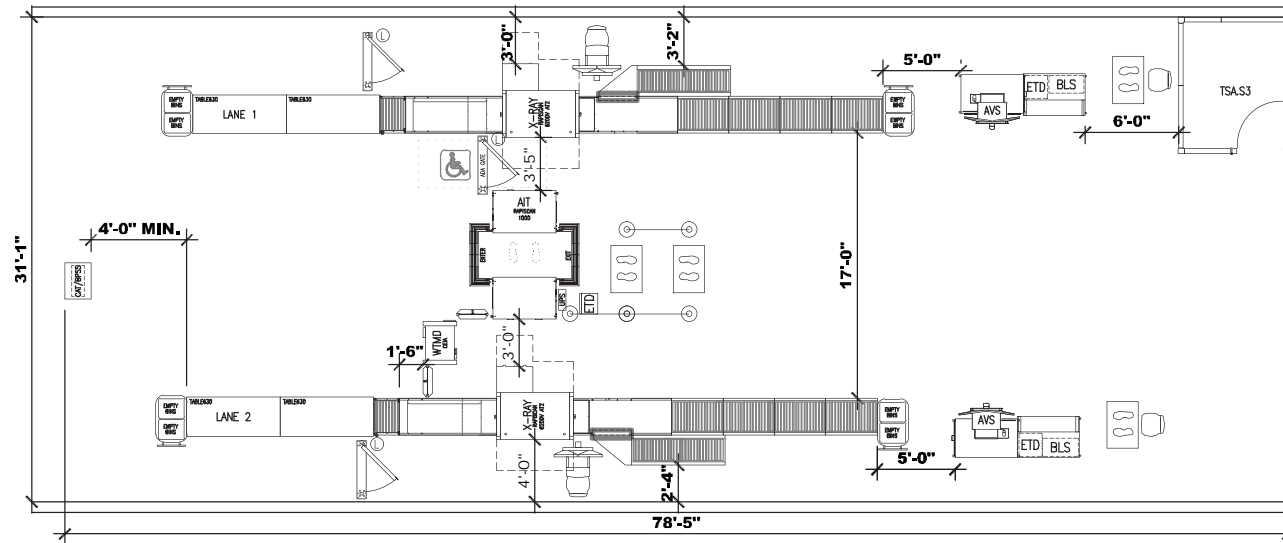

RAT.RAIT.3.3
Not To Scale

8.2 SMITHS AT X-RAY LAYOUTS

Figure 8-9 Single Lane SMITHS AT Bump In Layout

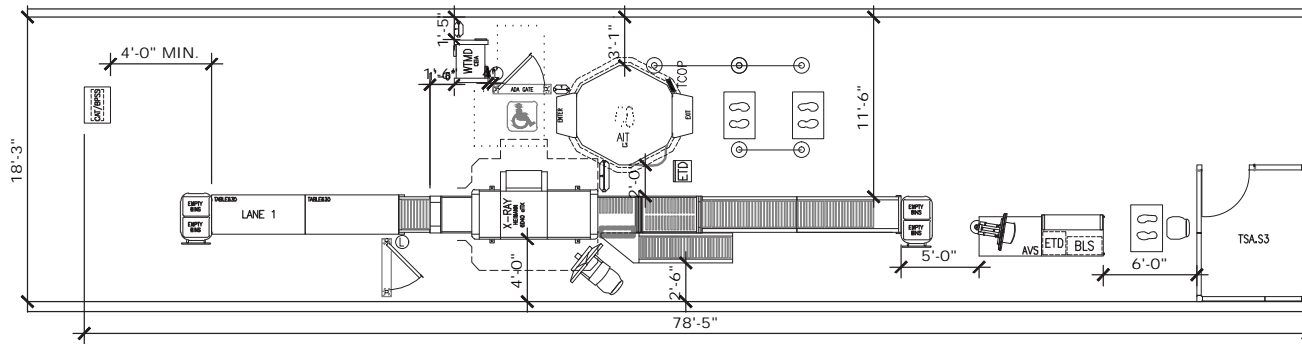

SAT.LAIT.1.1
Not To Scale

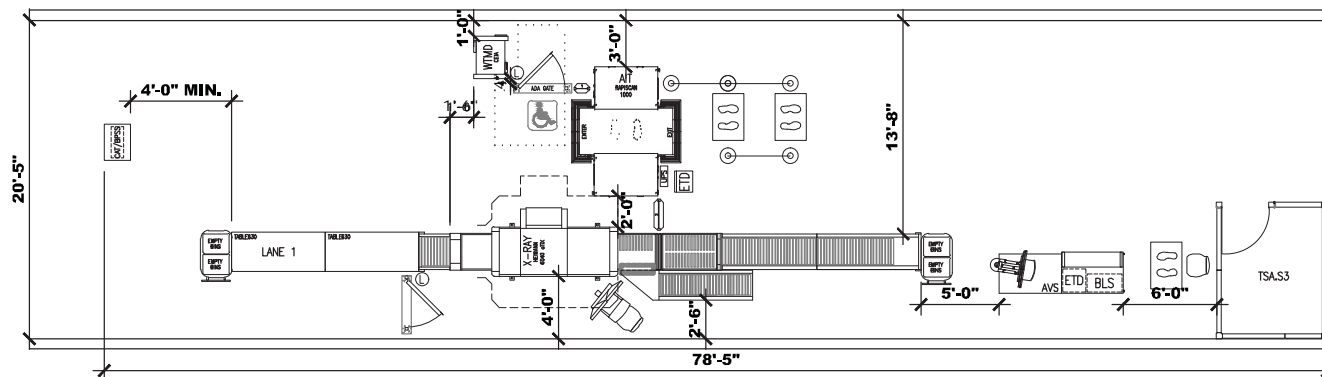

SAT.RAIT.1.1
Not To Scale

Figure 8-10 Single Lane SMITHS AT Bump Out Layout

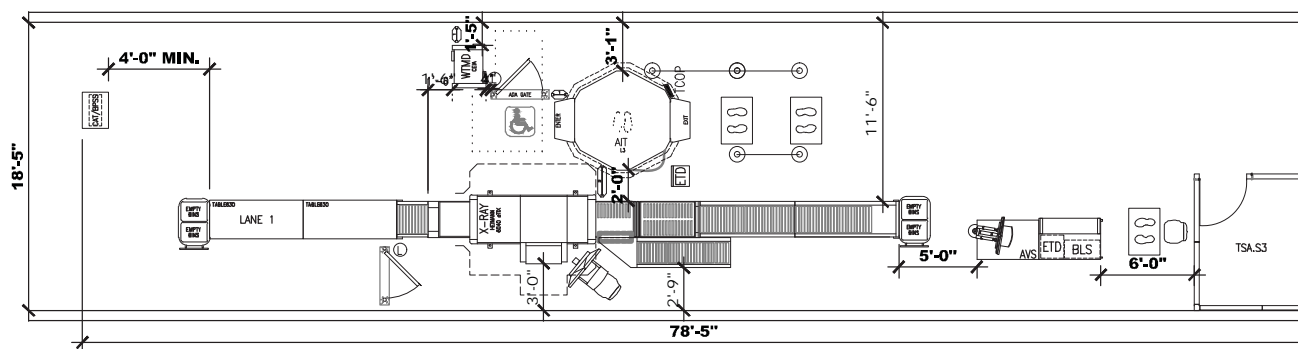

SAT.LAIT.1.2
Not To Scale

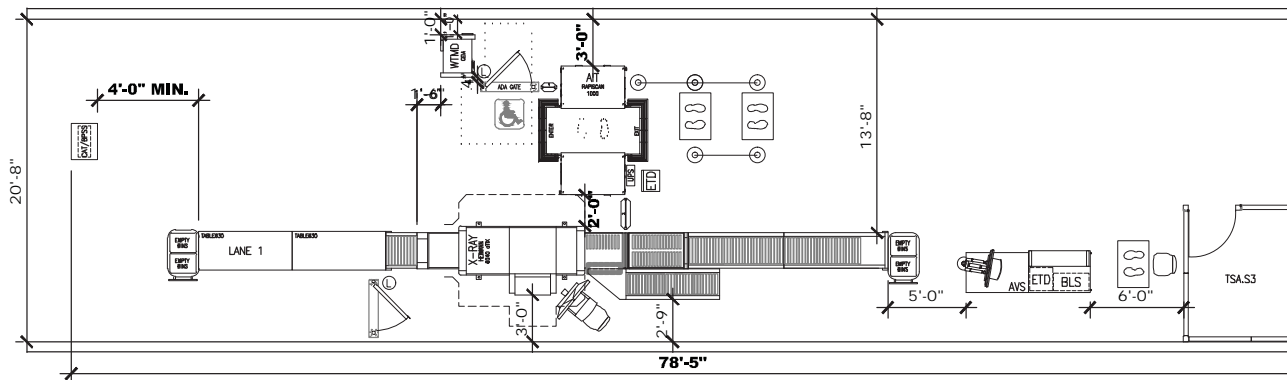

SAT.RAIT.1.2
Not To Scale

Figure 8-11 Two Lane SMITHS AT Bump In/Bump In Layout

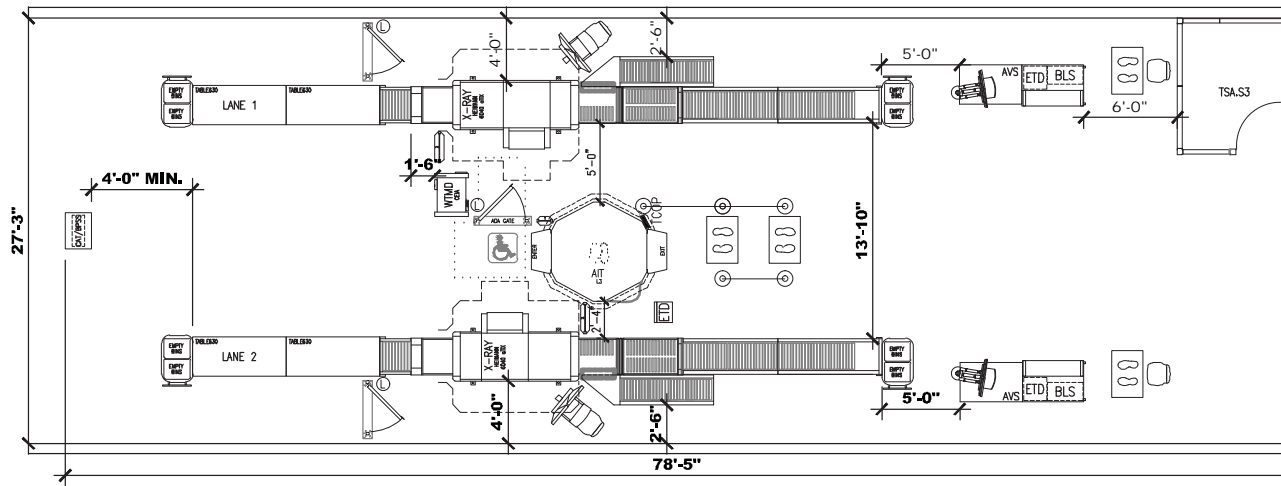

SAT.LAIT.2.1
Not To Scale

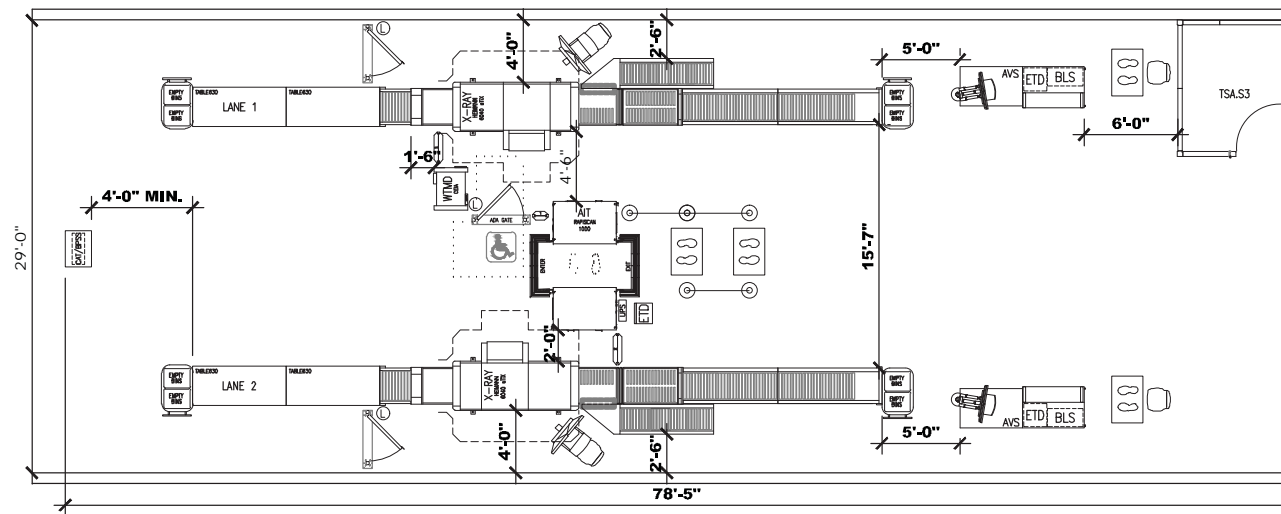

SAT.RAIT.2.1
Not To Scale

Figure 8-12 Two Lane SMITHS AT Bump Out/Bump Out Layout

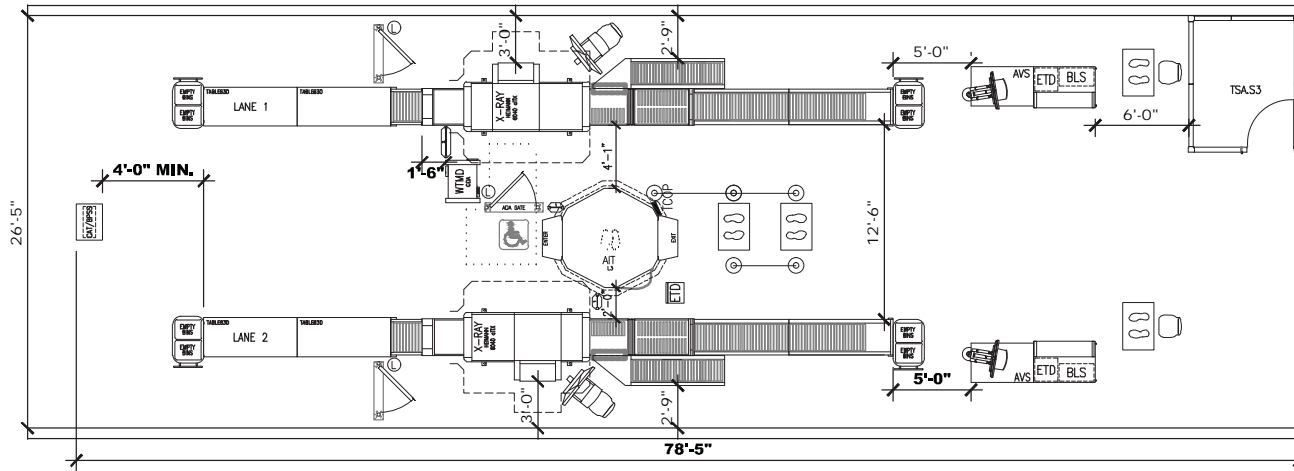

SAT.LAIT.2.2
Not To Scale

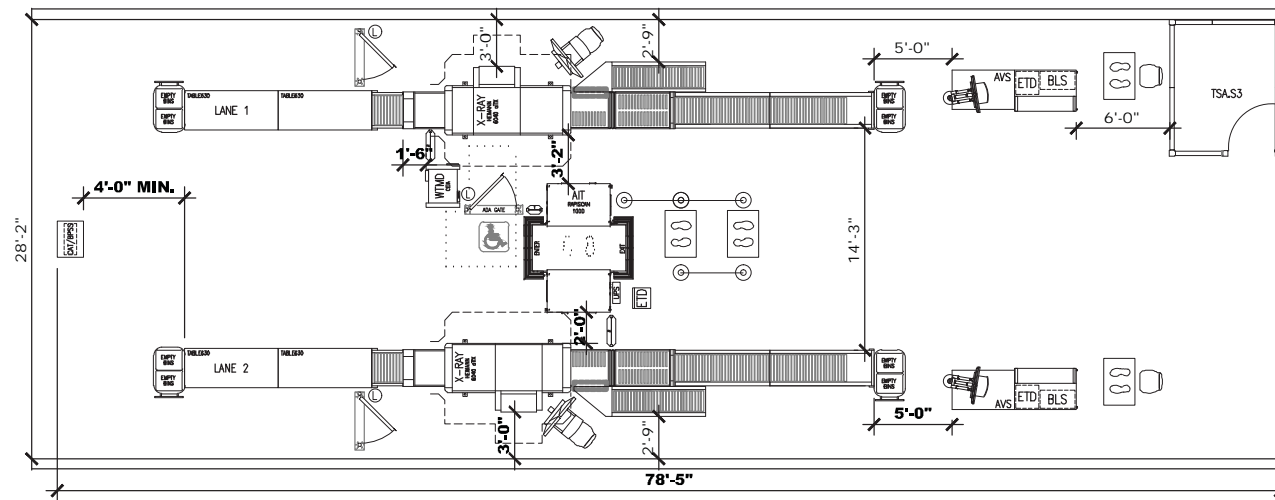

SAT.RAIT.2.2
Not To Scale

Figure 8-13 Two Lane SMITHS AT Bump In/Bump Out Layout

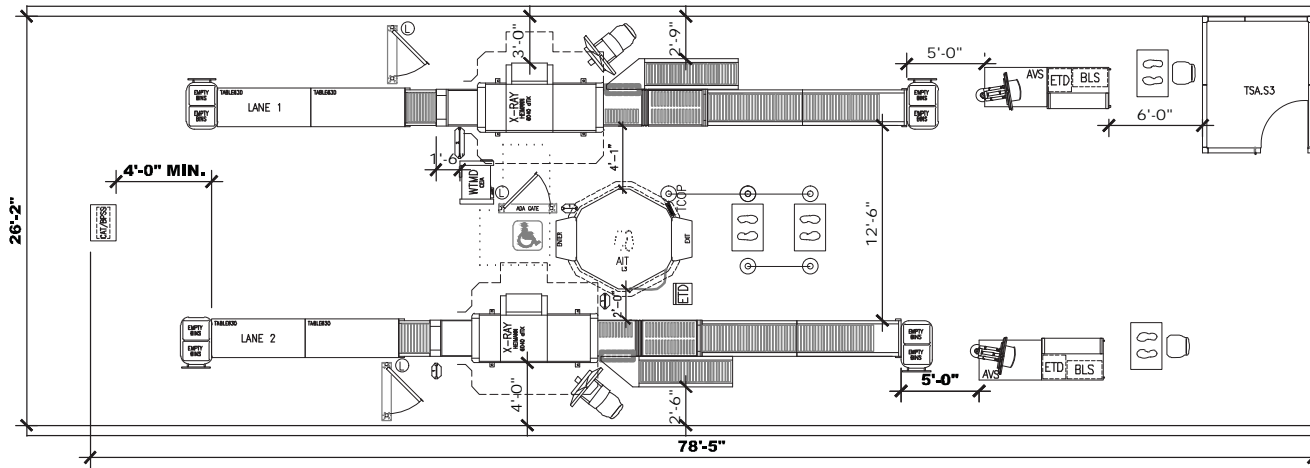

SAT.LAIT.2.3
Not To Scale

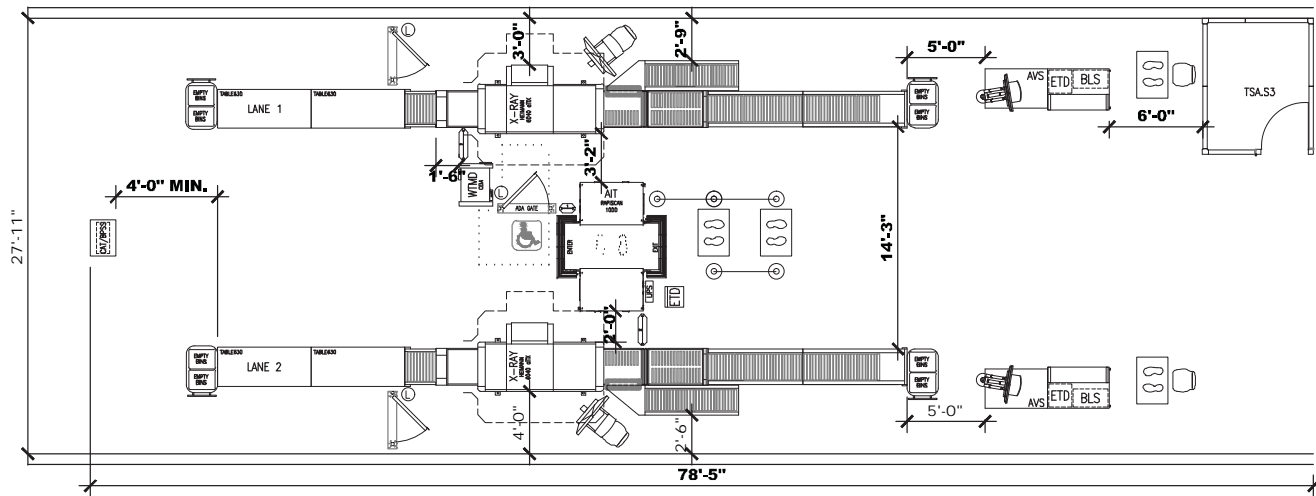

SAT.RAIT.2.3
Not To Scale

Figure 8-14 Two Lane SMITHS AT Bump In/Bump In Center AIT Layout

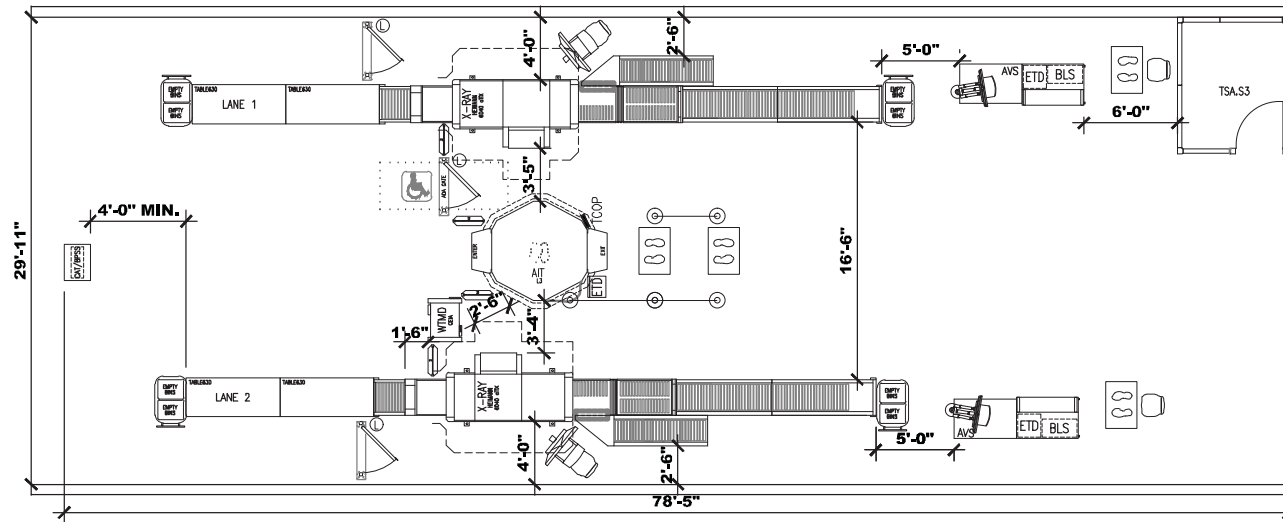

SAT.LAIT.3.1
Not To Scale

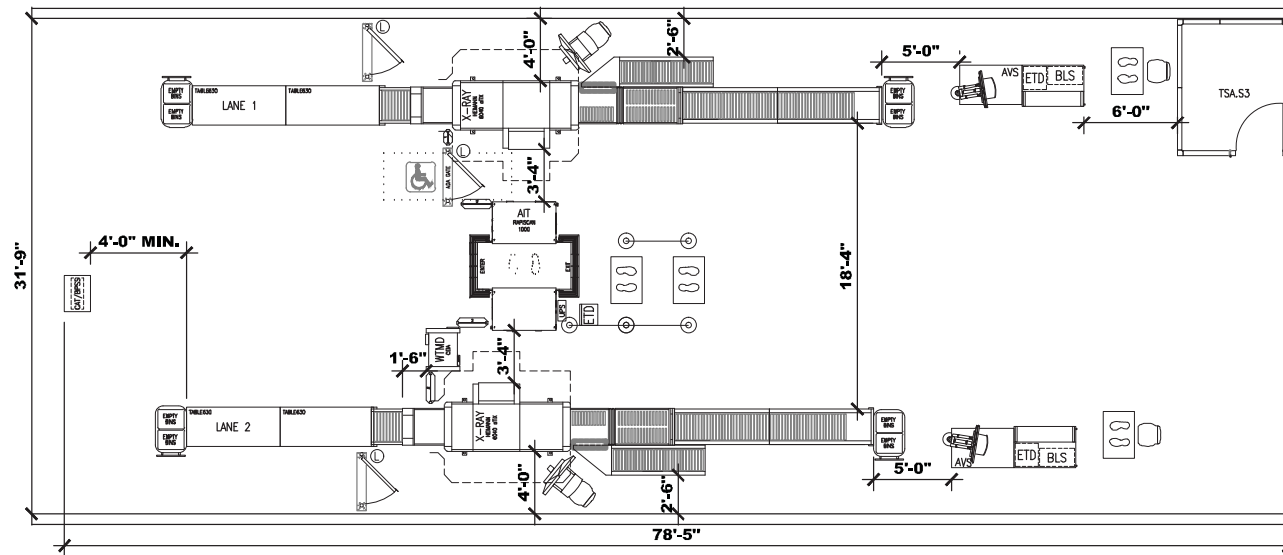

SAT.RAIT.3.1
Not To Scale

Figure 8-15 Two Lane SMITHS AT Bump Out/Bump Out Center AIT Layout

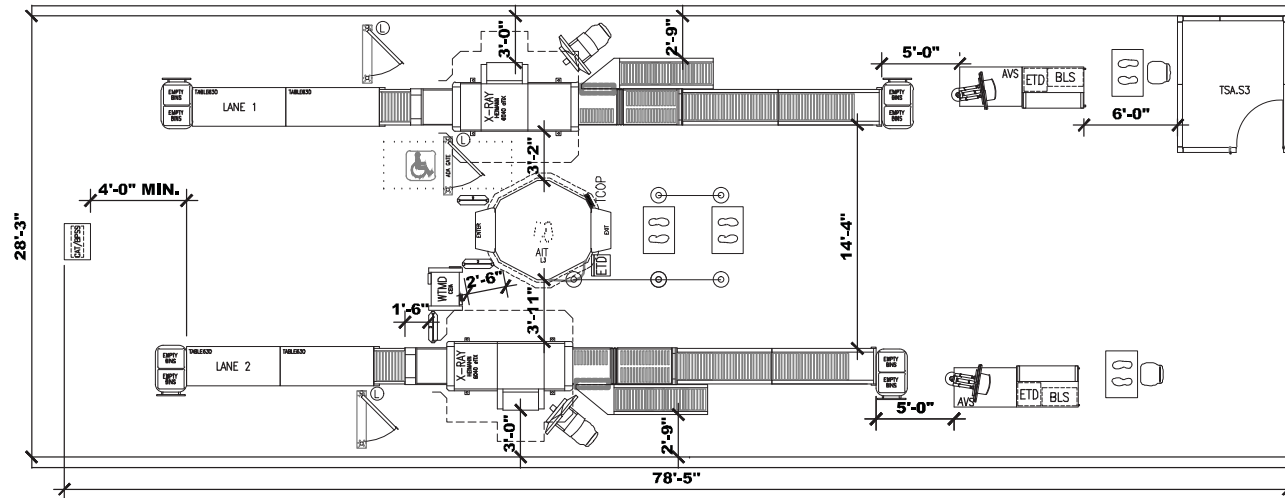

SAT.LAIT.3.2
Not To Scale

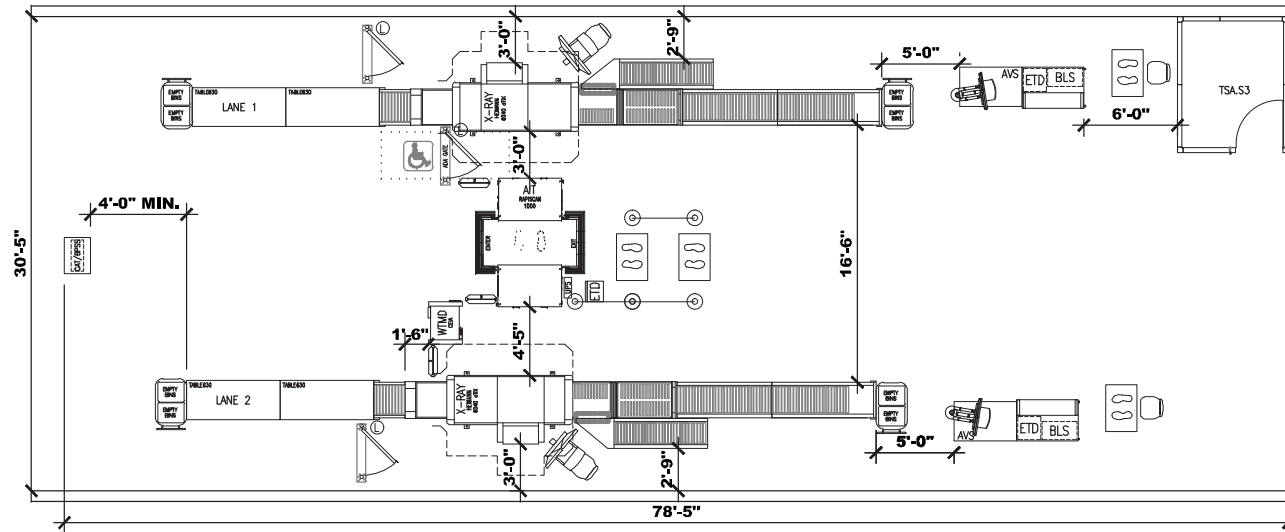

SAT.RAIT.3.2
Not To Scale

Figure 8-16 Two Lane SMITHS AT Bump In/Bump Out Center AIT Layout

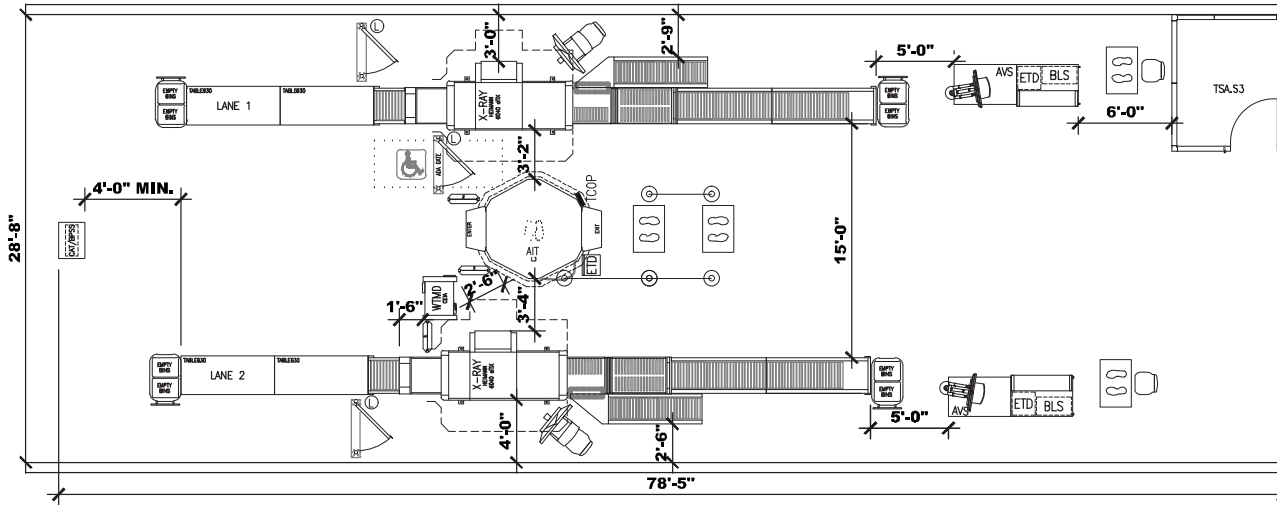

SAT.LAIT.3.3
Not To Scale

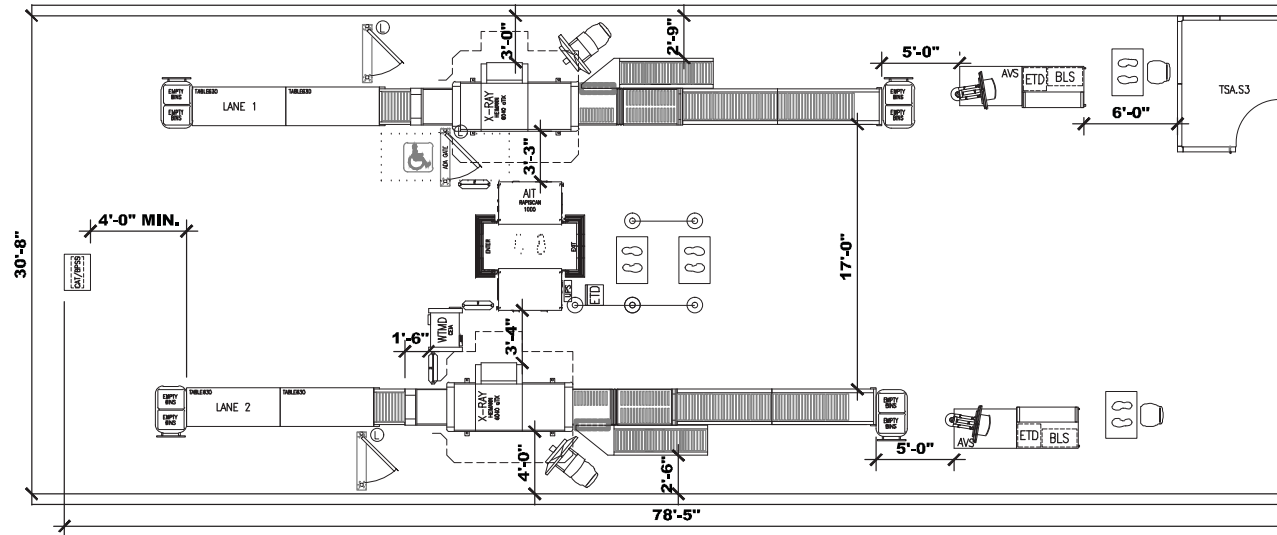

SAT.RAIT.3.3
Not To Scale

8.3 L3 AT X-RAY LAYOUTS

Figure 8-17 Single Lane L3 AT Bump In Layout

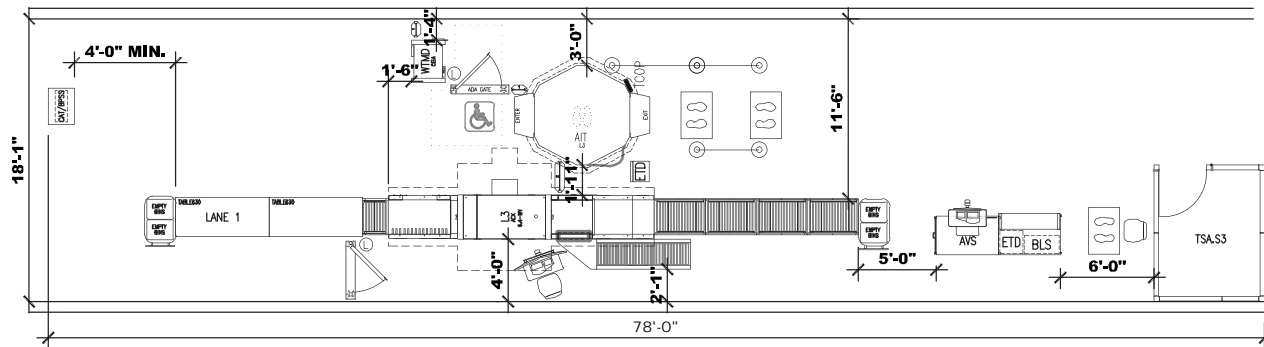

LAT.LAIT.1.1
Not To Scale

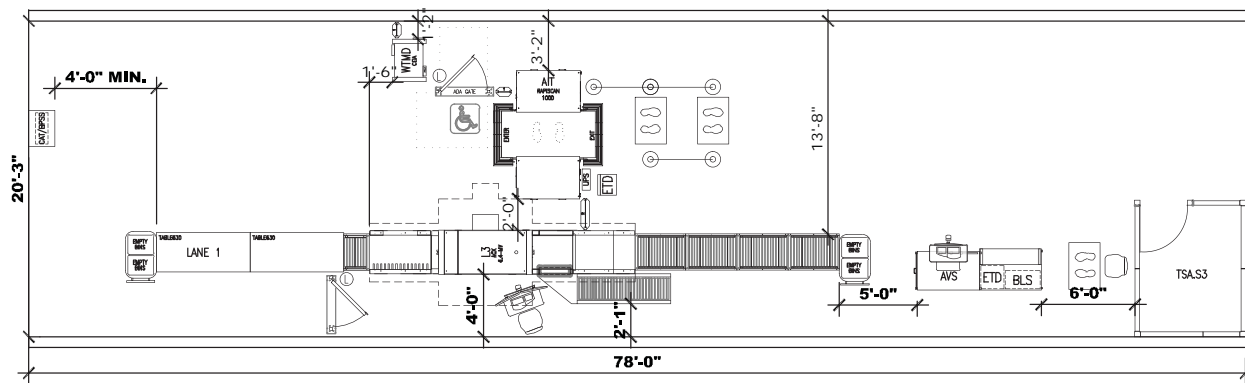

LAT.RAIT.1.1
Not To Scale

Figure 8-18 Single Lane L3 AT Bump Out Layout

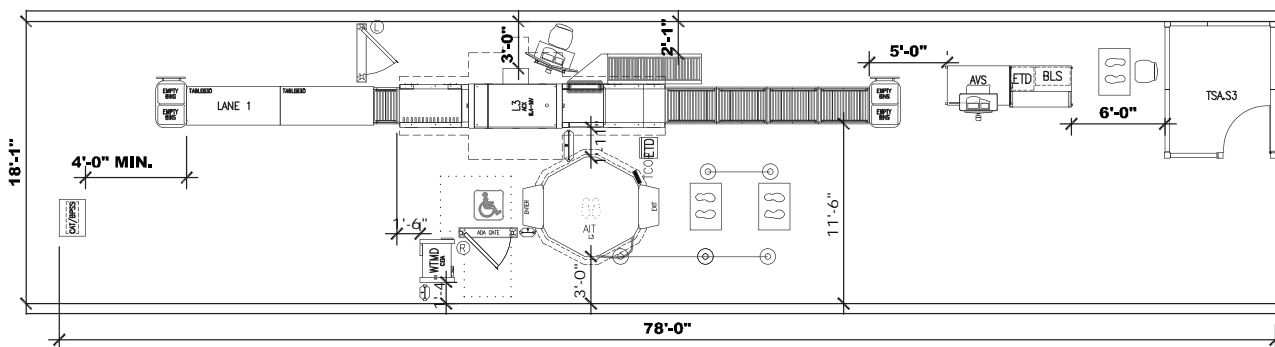

LAT.LAIT.1.2
Not To Scale

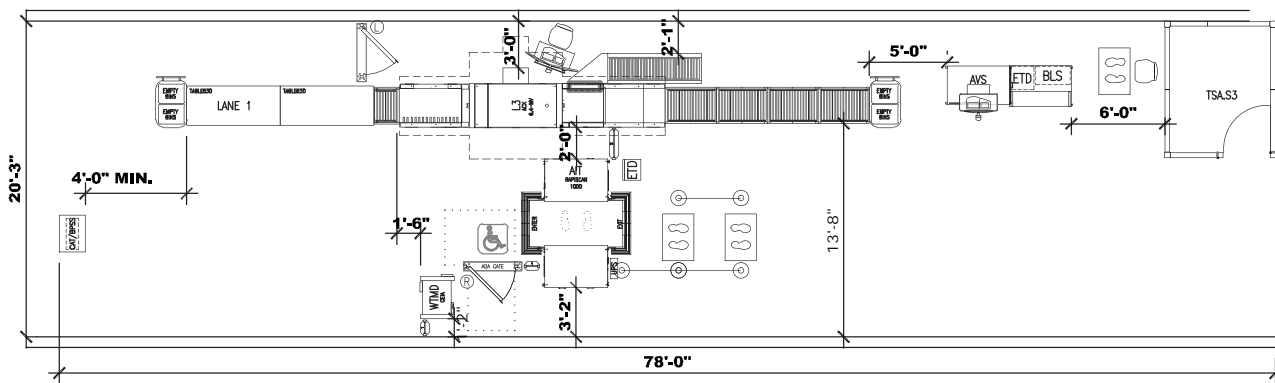

LAT.RAIT.1.2
Not To Scale

Figure 8-19 Two Lane L3 AT Bump In/Bump Out Layout

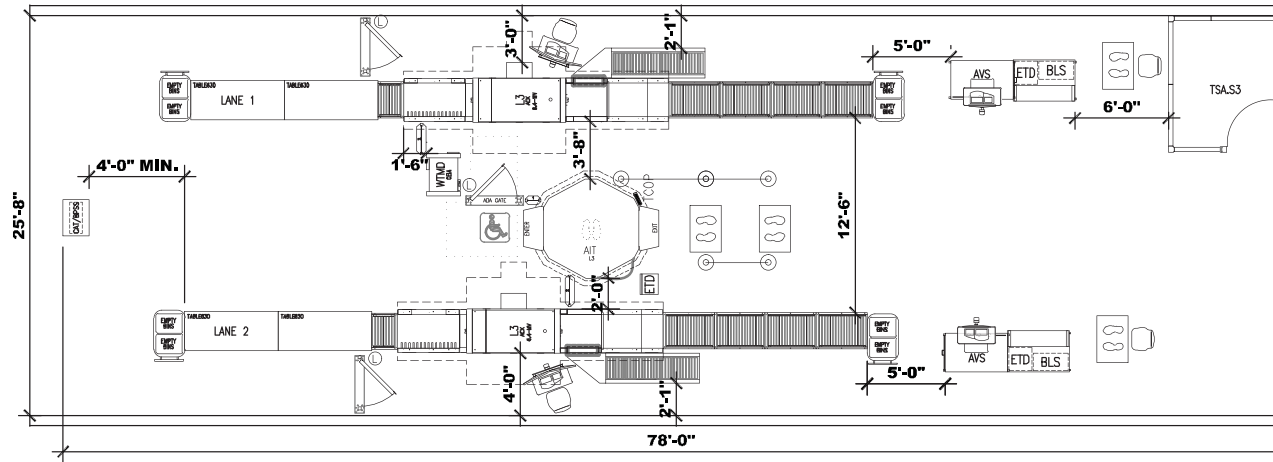

LAT.LAIT.2.3
Not To Scale

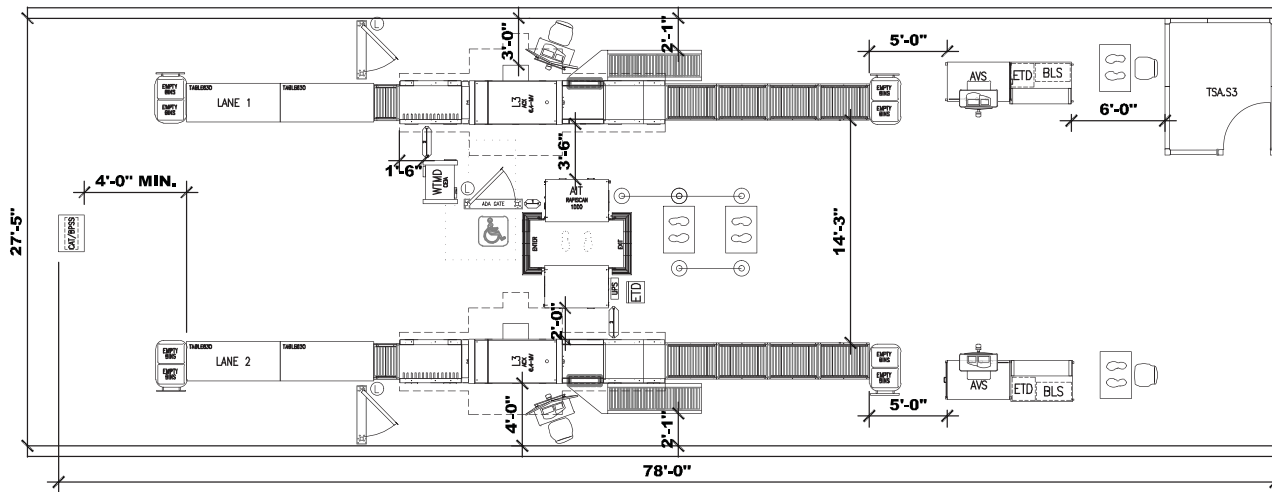

LAT.RAIT.2.3
Not To Scale

Figure 8-20 Two Lane L3 AT Bump In/Bump Out Center AIT Layout

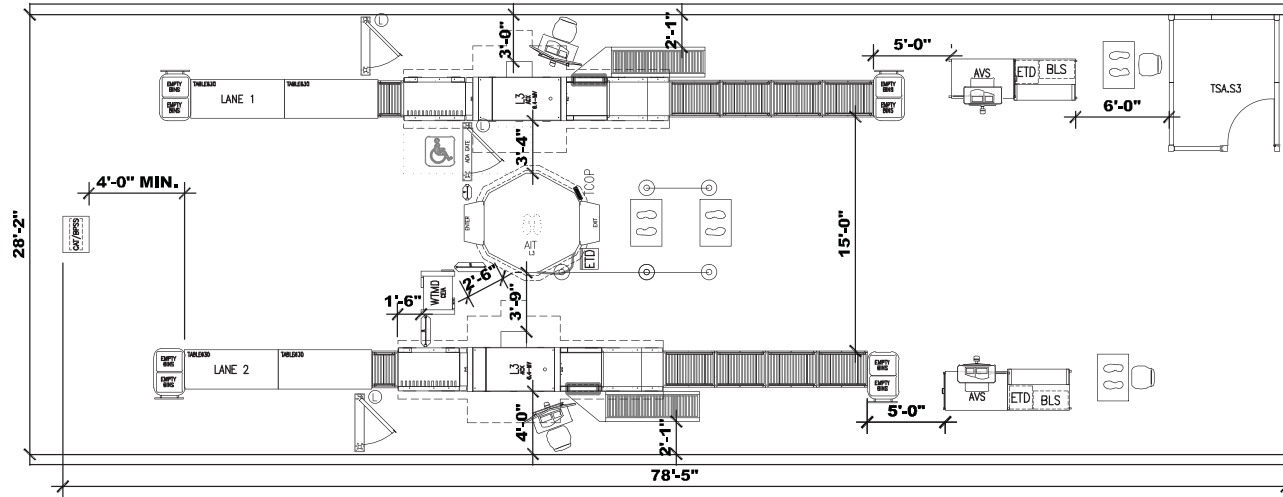

LAT.LAIT.3.1
Not To Scale

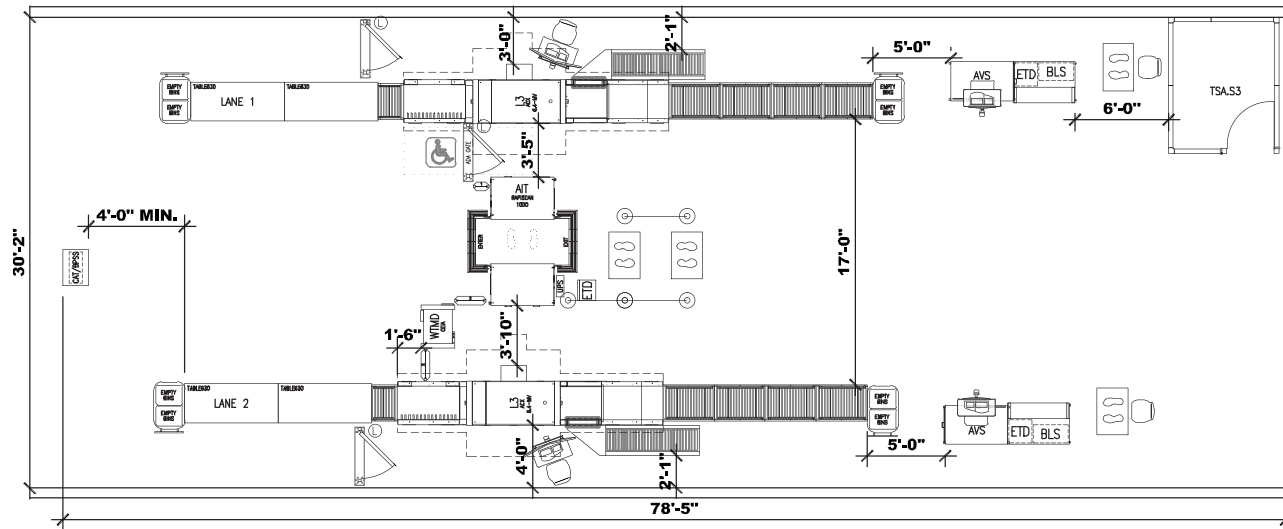

LAT.RAIT.3.1
Not To Scale

This page is intentionally left blank.

9.0 *APPENDIX D - LEGACY ITEMS*

The following items are no longer being incorporated into updated checkpoint designs. It is possible that some of these legacy items exist in the field as part of previous layouts, but future use of these systems is not approved.

9.1 QUEUE (REFER TO SECTION 2.2)

9.1.1 Diamond Self Select (DSS)

The Diamond Self Select Screening Program was introduced to better organize passengers in the queue to reduce the passenger frustration level and create a calmer environment. This program allows passengers to select a different queue lane based on their individual needs. Passengers can choose one of the following three paths to match their frequency of travel and knowledge of TSA procedures.

● **Family/Medical Liquids (Green Circle):** This queue lane is intended for passengers carrying exempt, non compliant liquids, who may or may not be familiar with TSA procedures but may be traveling in groups, with children and strollers, with elderly persons, or with persons requiring special assistance. Any checkpoint with more than one screening lane must have a dedicated Family/Medical Liquids screening lane. This is a mandatory requirement of the TSA Liquid Screening Program. A designated queue lane may or may not feed this mandatory screening lane. If there is a designated Family/Medical Liquids queue lane, it should be a minimum of 3'-6" wide.

- » *ADA Accessible:* This can be a dedicated queue lane or, in some cases, where queue space is limited or awkward, it can merge or be combined with the Family/Medical Liquids queue and screening lane.
- » *Crew/Employee:* This can be a dedicated queue lane, space permitting. As an alternative, airline crew, airport employees, and concession staff can be included in the Family/Medical Liquids queue. However, the queue should be at least 5'-0" wide to allow crew and employees to bypass slower passengers or groups. While the movement through this queue may be slow, the path is typically short and straight, allowing crew and employees to get through the checkpoint faster.

■ **Casual Passengers (Blue Square):** This queue lane consists of passengers who are somewhat familiar with TSA procedures and travel occasionally with multiple carry-on bags. The minimum queue lane width is 3'-0". The Casual Passenger queue lane should be the first queue passengers see as they approach the SSCP since a majority of passengers will be casual passengers, and as a general rule, passengers will enter the first queue they reach regardless of designation.

◆ **Expert Travelers (Black Diamond):** This queue lane contains passengers who are very familiar with TSA procedures and travel frequently. The minimum queue lane width is 3'-0". Whenever possible, the Expert Traveler queue lane should be located at the far end of the queue since expert passengers will typically travel distances to get where they are going. A dedicated queue lane from the entrance to the divest area can be stanchioned off for expert travelers.

- » *Premium/1st Class:* TSA does not support a dedicated queue lane for this class. These passengers frequently fit into the Expert Traveler queue since most expert travelers are frequent flyer members.

Figure 9-1 is an example of a DSS queue layout. Note that the Family/Medical Liquids Lane (Green Circle) is mandatory. The exact queue design at each airport is fluid and will vary in length and width since each airport serves a different mix of passengers. Allocate queue space based on the airport passenger demographics. For example, some airports allocate 15 percent of the overall queue for the Family/Medical Liquids queue lane, 60 percent for the Casual Passenger queue lane, and 25 percent for the Expert Traveler queue lane.

LEGEND





-  ADA ACCESSIBLE
-  FAMILY/MEDICAL LIQUIDS
-  CASUAL PASSENGERS
-  EXPERT TRAVELERS

Figure 9-1 DSS Queue Example



9.2 CARRY-ON BAG SCREENING (SEE SECTION 2.5)

9.2.1 Threat Image Projection (TIP) Ready X-Ray (TRX)

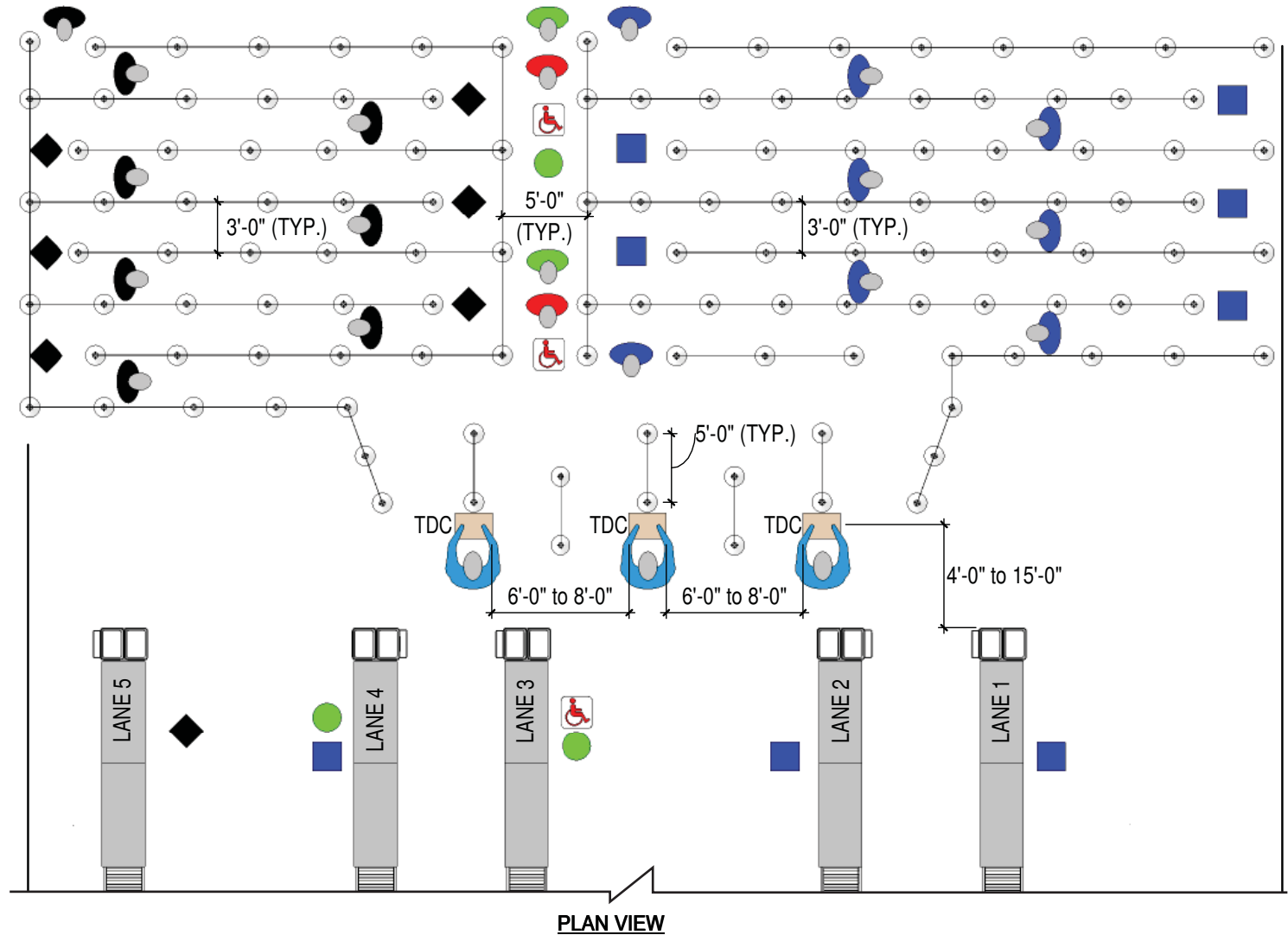
Until recently, the TRX was the most common type of X-ray equipment deployed at SSCPs. The TRX may be present in airports, but is no longer actively deployed. **Figure 9-2** displays the two most common TRX vendors. These units come in two sizes. The smaller size is used almost exclusively for all lanes. The other size is for larger carry-on baggage such as strollers, infant car seats, etc. This larger size is typically installed in just one lane of the checkpoint, if at all.

The TRX comes in a Right Hand (RH) or Left Hand (LH) orientation. The “hand” is dependant on where the TRX operator sits when standing on the non-sterile side of the TRX looking at the infeed tunnel. A TRX is a RH unit when the operator is sitting on the right side of the dome. The dome is where the “brain” of the system is

located. It is the rectangular shaped portion of the TRX where the bag X-ray occurs. A TRX is a LH unit when the operator is sitting on the left side of the dome. The orientation can be changed easily in the field by the manufacturer should a different hand be required when rearranging the checkpoint.

TRX units typically come with composeure/extension rollers and/or exit rollers. Extension rollers are located between the HSC and the exit roller. An exit roller is the same as a composeure/extension roller but it is the last roller of the TRX and it has a bag stop at the end. Some of the TRX extension and exit rollers are compatible with the AT X-ray. Only compatible extension rollers should be used. The AT X-ray is discussed further in Section 2.5.2 and the composeure/extension rollers are discussed in Section 2.5.4. Detailed specifications of the TRX units are included in **Figure 9-3** and **Figure 9-4**.

Figure 9-2 TRX Units

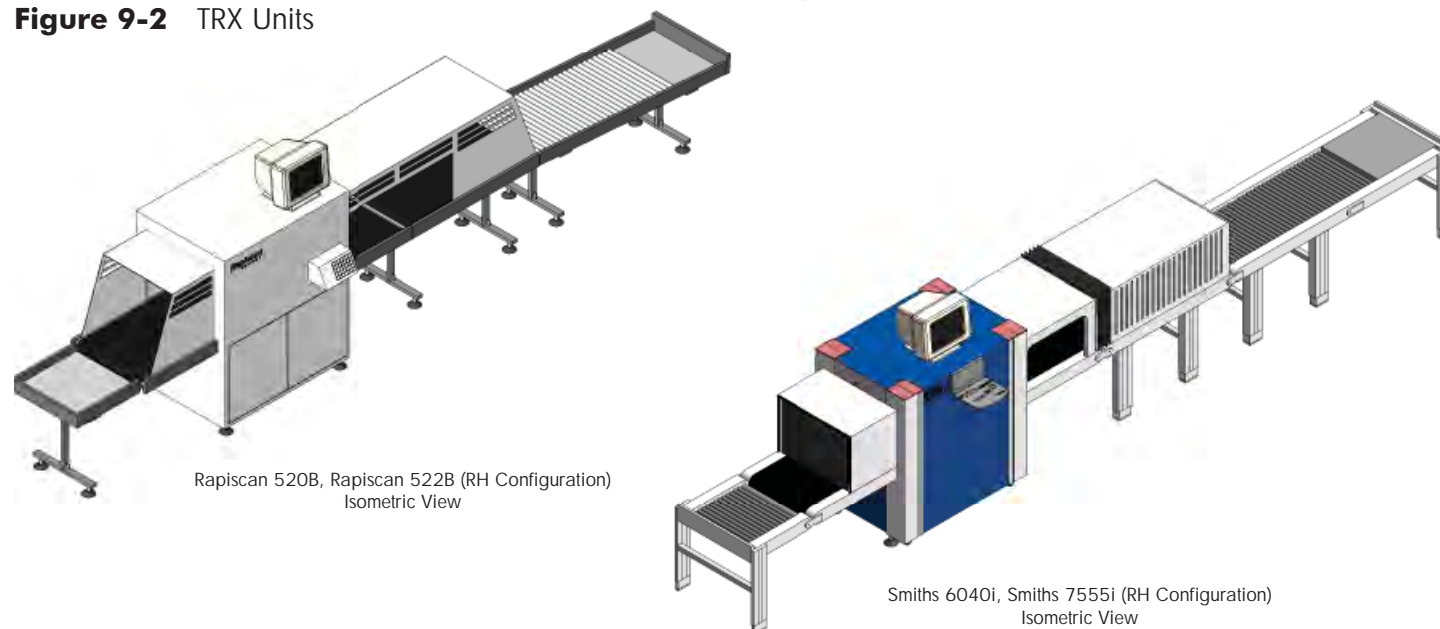

Figure 9-3 TRX - Rapiscan

Equipment	Quantity	Power Requirements	IT Requirements	Additional Information
Rapiscan 520B Rapiscan 522B	1 per lane	<ul style="list-style-type: none"> Dedicated 20A, 125V, 1200VA/unit 2-Pole, 3-Wire Grounding NEMA 5-20R Duplex Receptacle 15' power cord from the TRX the receptacle 	<ul style="list-style-type: none"> Data Drops = 2 Cat5e / Cat6 cable The cable length from the termination point in the IT cabinet to the TRX data outlet shall not exceed 295'. 	<ul style="list-style-type: none"> Composure length can be increased by adding one or more Rapiscan 1m (3'-3") extension rollers between the HSC and the exit roller. Rapiscan 520B and 522B units are no longer being purchased by TSA. Weight: <ul style="list-style-type: none"> Rapiscan 520B: 1,232 lbs. Rapiscan 522B: 1,367 lbs.

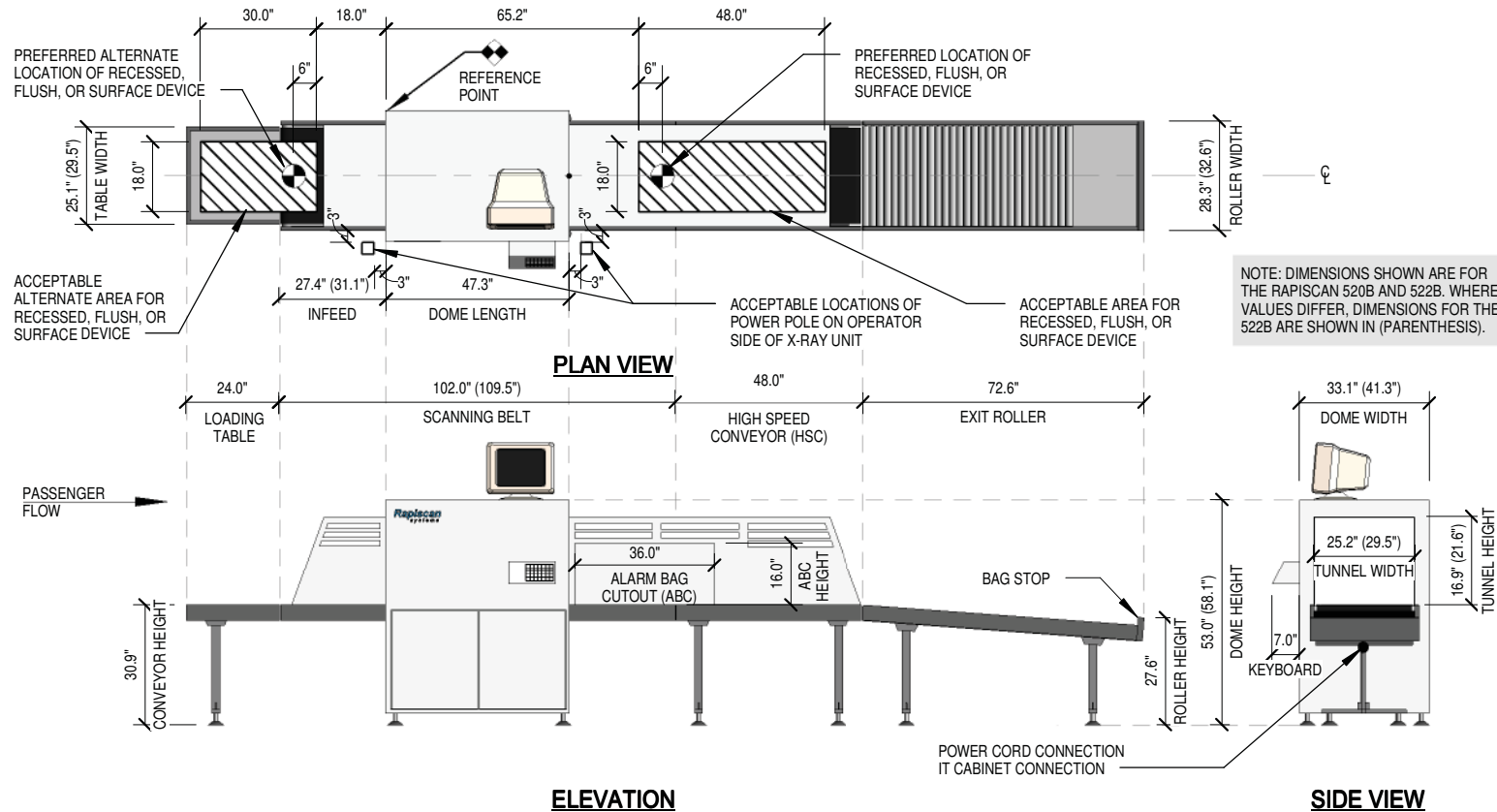
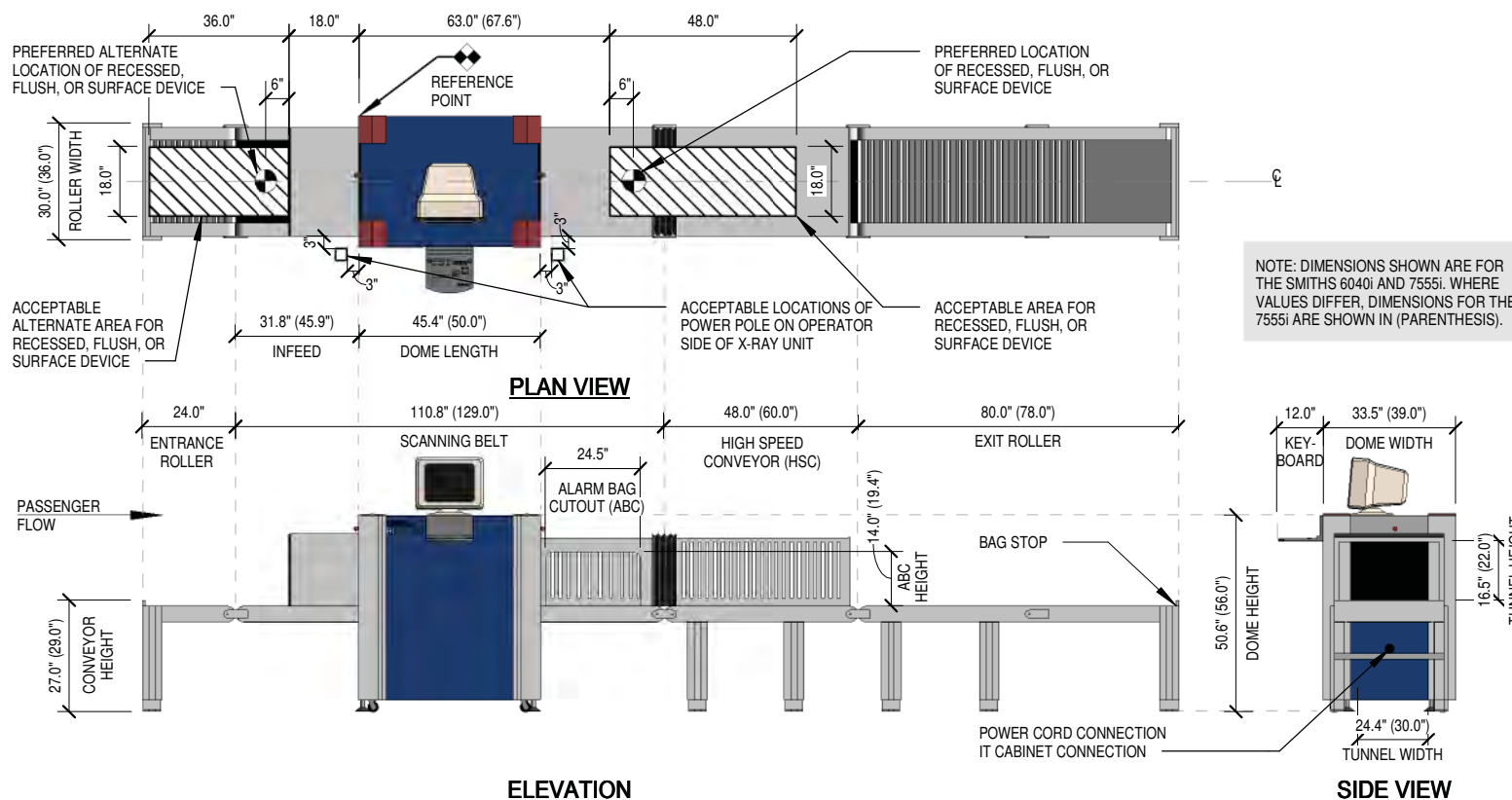

Figure 9-4 TRX - Smiths

Equipment	Quantity	Power Requirements	IT Requirements	Additional Information
Smiths 6040i Smiths 7555i	1 per lane	<ul style="list-style-type: none"> Dedicated 20A, 125V, 800VA/unit 2-Pole, 3-Wire Grounding NEMA 5-20R Duplex Receptacle 15' power cord from the TRX the receptacle 	<ul style="list-style-type: none"> Data Drops = 2 Cat5e / Cat6 cable The cable length from the termination point in the IT cabinet to the TRX data outlet shall not exceed 295'. 	<ul style="list-style-type: none"> Composure length can be increased by adding one or more Smiths 48" or 72" extension rollers between the HSC and the exit roller. Smiths 6040i and 7555i units are no longer being purchased by TSA. Weight: <ul style="list-style-type: none"> » Smiths 6040i: 882 lbs. » Smiths 7555i: 1,279 lbs.



9.3 ADVANCED IMAGING TECHNOLOGY (SEE SECTION 2.7)

9.3.1 Image Resolution

The AIT images are viewed remotely by an Image Operator (IO) at an AIT workstation located in a Remote Resolution Room. This room can either be a glass kit or an airport-provided sheetrock or concrete room located at or near the checkpoint. The requirement for this room and the AIT operator workstations will not be required once the AIT is deployed with Automatic Target Recognition (ATR).

9.4 PASSENGER CONTAINMENT, INSPECTION & RESOLUTION (SEE SECTION 2.10)

9.4.1 Passenger Containment (J3)

Passenger containment at the screening lanes can be achieved by using either a J3 glass kit. **Figure 9-5** reflects the dimensions of the J3. The J3 kit is referred to as a holding station because it can “hold” up to three alarmed passengers simultaneously until a TSO becomes available to escort the passenger to the secondary screening area. The J3 kit is constructed of clear, modular 4'-0" wide by 6'-0" high glass panels with a 3'-0" door that can be latched on the outside by TSA.

A passenger diverted to the holding station has alarmed the WTMD, or the passenger was unable to traverse the WTMD because he/she is in a wheelchair or has a pacemaker. The holding station must be positioned near the WTMD so that passengers can be diverted

directly into it without obstructing the path of passengers who were successfully cleared through the WTMD. The holding station must also prevent the passage of prohibited items from passengers in the holding station to cleared passengers in the sterile area. Checkpoints that are narrow and deep are ideal for holding stations.

Figure 9-5 J3

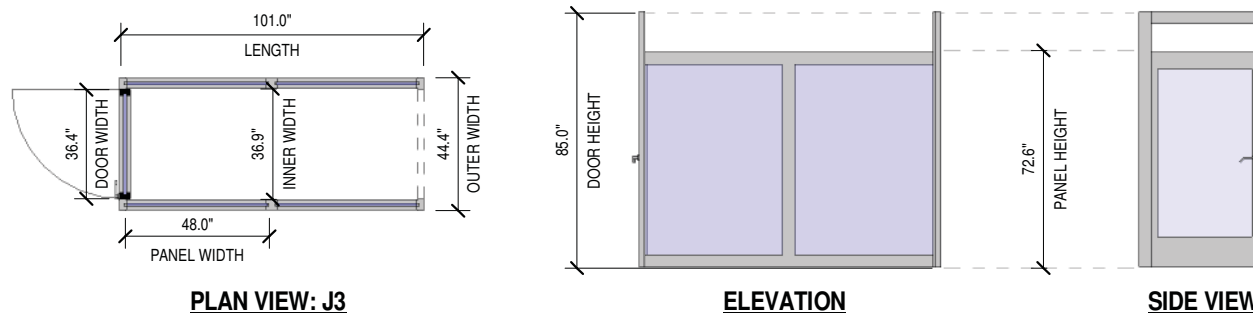

9.4.2 Passenger Inspection (N3)

Passenger inspection at the screening lanes can be achieved by using an N3 glass kit. **Figure 9-6** reflects the dimensions of this kit. This kit is referred to as a holding/inspection station because it can “hold” up to two alarmed passengers simultaneously for inspections or pat downs. Sometimes passenger inspection mats are located inside this kit. A checkpoint can be designed with inspection kits at every lane, or it can have a combination of both containment and inspection kits. This will depend on the space available and any existing obstructions. This kit is constructed of clear, modular 4’-0” wide by 6’-0” high glass panels with a 3’-0” door that can be latched on the outside by TSA.

A passenger who is diverted to the holding/inspection station has alarmed the WTMD, or is unable to traverse the WTMD because he/she is in a wheelchair or has a pacemaker. The holding/inspection station must be positioned near the WTMD so that passengers can be diverted directly into it without obstructing the path of passengers who were successfully cleared through the WTMD. The holding/inspection station must also prevent the passage of prohibited items from passengers in the holding/inspection station to cleared passengers in the sterile area. Checkpoints that are wide and deep are ideal for holding/inspection stations.

Figure 9-6 N3

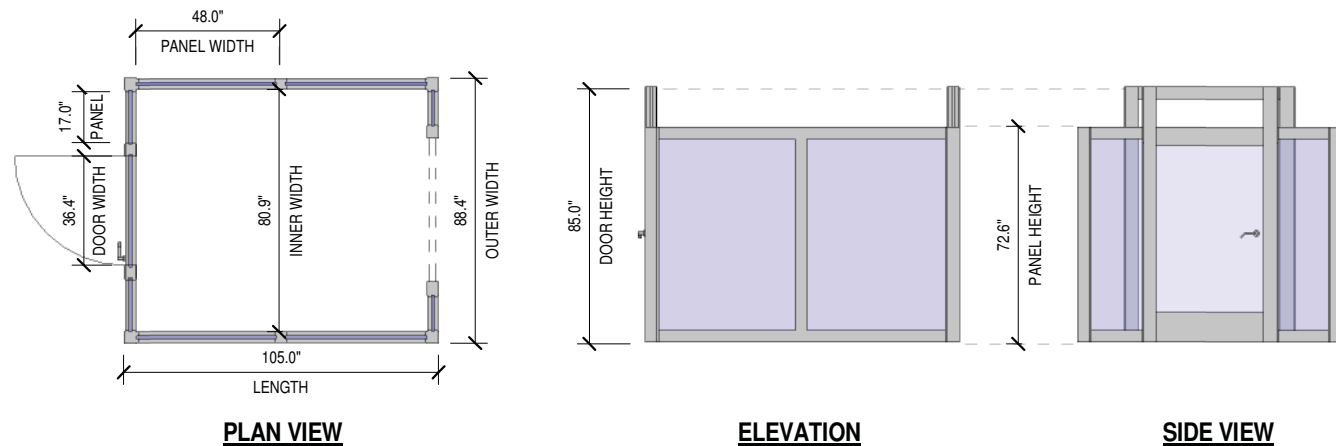

9.4.3 Cast & Prosthesis Imager

The Cast & Prosthesis Imager (CPI) in **Figure 9-7** is the first system designed to address the unique screening requirements for persons with casts, prosthetic devices, and support braces. These devices often contain metal components that set off the WTMD. A CPI complements the WTMD by using advanced backscatter technology to create a detailed image of the inside of the device. A CPI enables TSOs to screen prosthetics in a more effective, comfortable, convenient, and non-intrusive manner. This tool also provides the ability to locate prohibited items that could be stored in a cast, prosthetic, or brace. CPI screening should be completed after primary and secondary screening has taken place. All passengers with a cast, prosthetic or brace must undergo this process if the equipment is available at the SSCP regardless of whether they have alarmed any other device. The unit should be accessible outside the PSR as a reminder to the TSO that this is the last screening requirement for special needs travelers. Because the CPI has wheels, it can be taken into the Private Screening Room, if requested. The wheels should be locked during screening functions. Power/data for the CPI or some other future device should be provided inside and outside the room as indicated in the plan view of **Figure 2-32**.

Figure 9-7 CPI Unit

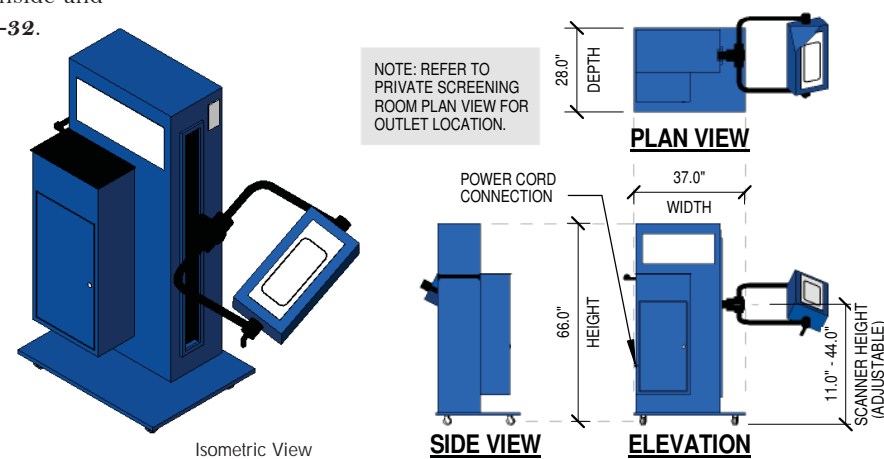

9.4.4 Remote Resolution Room (I/O Room) with AIT Operator Workstation

The Remote Resolution Room, shown in **Figure 9-9**, is approximately 6'-0" by 8'-0" with 8'-0" high glass panels and a 3'-0" door on either the short wall (S3) or the long wall (S3-A). Remote Resolution Rooms exist in relation to the Rapiscan AIT. The Remote Resolution Room should be located within the manufacturer's recommended distance from the AIT. The door should not directly face the screening lanes or passenger egress in order to prevent viewing of the workstation images. The finish of the glass panels is opaque so that privacy is maintained. If the Remote Resolution Room can be viewed from a concourse above or if cameras are located above or aimed at the room, then a baffle kit consisting of slats should be installed to prevent a direct line-of-sight into the room. Refer to **Figure 2-30**.

Due to privacy and operational requirements, the Remote Resolution Room must meet the following conditions.

- The room should be located no more than 295' from the AIT.
- A lock must be provided on the door inside the room.
- The walls must be opaque and 8'-0" high or greater on all sides.
- A minimum of 49 square feet must be provided for two operators.
- The door of the room should be located so that there is no line-of-sight from passengers or TSA agents into the room.
- The room should be located at or as close to the checkpoint as possible to allow for an efficient rotation of staff.
- Cell phones, CCTV, video cameras, or other image-capturing devices are not allowed inside the room.

Each AIT has an operator workstation that needs to be located in the Remote Resolution Room. The standard S3 or S3-A kit can accommodate up to two workstations. The power/data location shown on the plan views allows for both workstations to be

fed. Should more workstations be needed, the walls perpendicular to the wall containing the door can be expanded in 4'-0" increments for up to four operators. The wall opposite the wall containing the door will need to be relocated with the expansion. The L3 operator workstation is called a Lane Control Unit (LCU) which consists of a monitor, keyboard, and PC located on a TSA-provided table. The Rapiscan operator workstation is its own self-contained workstation where the monitor, keyboard, and PC are mounted to a vendor-provided table. The requirement for this room and operator workstations will go away once the AIT is deployed with ATR. ATR is discussed further in Section 3.4.

Figure 9-8 Rapiscan AIT Operator Workstation

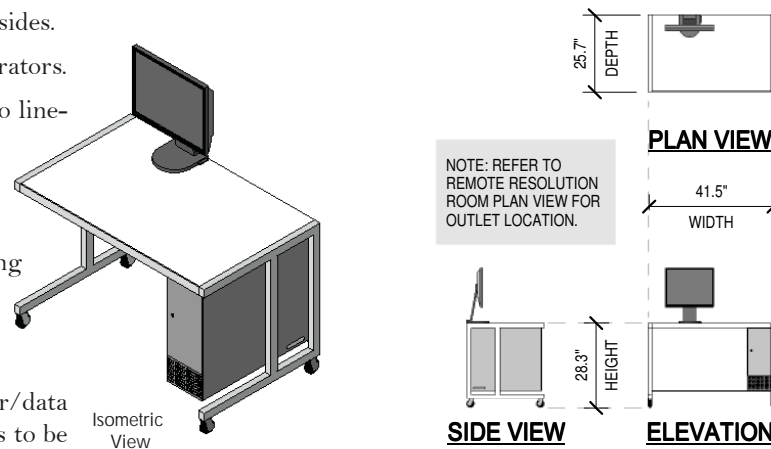
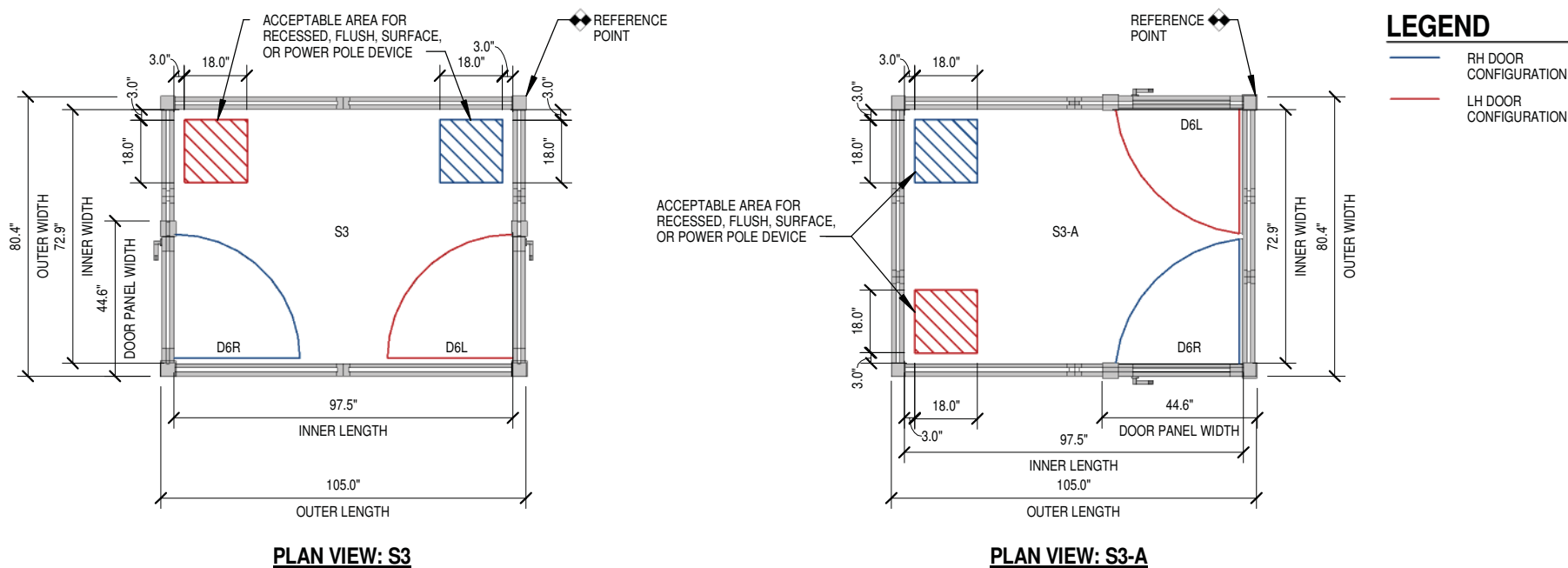

Figure 9-9 Remote Resolution Room (I/O Room) with AIT Operator Workstation

Equipment	Quantity	Power Requirements	IT Requirements	Additional Information
L3 AIT LCU Rapiscan AIT Operator Workstation	1 per AIT	<ul style="list-style-type: none"> Dedicated circuit 2-Pole, 3-Wire Grounding NEMA 5-20R Quad or Duplex Receptacle L3: <ul style="list-style-type: none"> » 20A, 125V, 1920VA/unit » 8' power cord from the LCU to the receptacle Rapiscan: <ul style="list-style-type: none"> » 20A, 125V, 720VA/unit » 6' power cord from PC tower to the receptacle 	<ul style="list-style-type: none"> Data Drops = 2 The cable length from the termination point in the IT cabinet to the data outlet in the work area shall not exceed 295'. L3: <ul style="list-style-type: none"> » 164' vendor-provided Cat6 cable from the L3 AIT to the LCU. Rapiscan: <ul style="list-style-type: none"> » Contractor-provided Cat5e cable from the Rapiscan AIT to the operator workstation. 	<ul style="list-style-type: none"> S3 or S3-A room can accommodate up to 2 operators. Room can be expanded in 4' increments for up to 4 operators. S3 and S3-A kits contain 8' high glass panels. S3 and S3-A kits can have LH or RH door swings. Power/data should be located based on door configuration. The default from KI Wall is a RH door swing. LH door swings must be specified. S3 and S3-A kits may be installed with optional baffle kits.





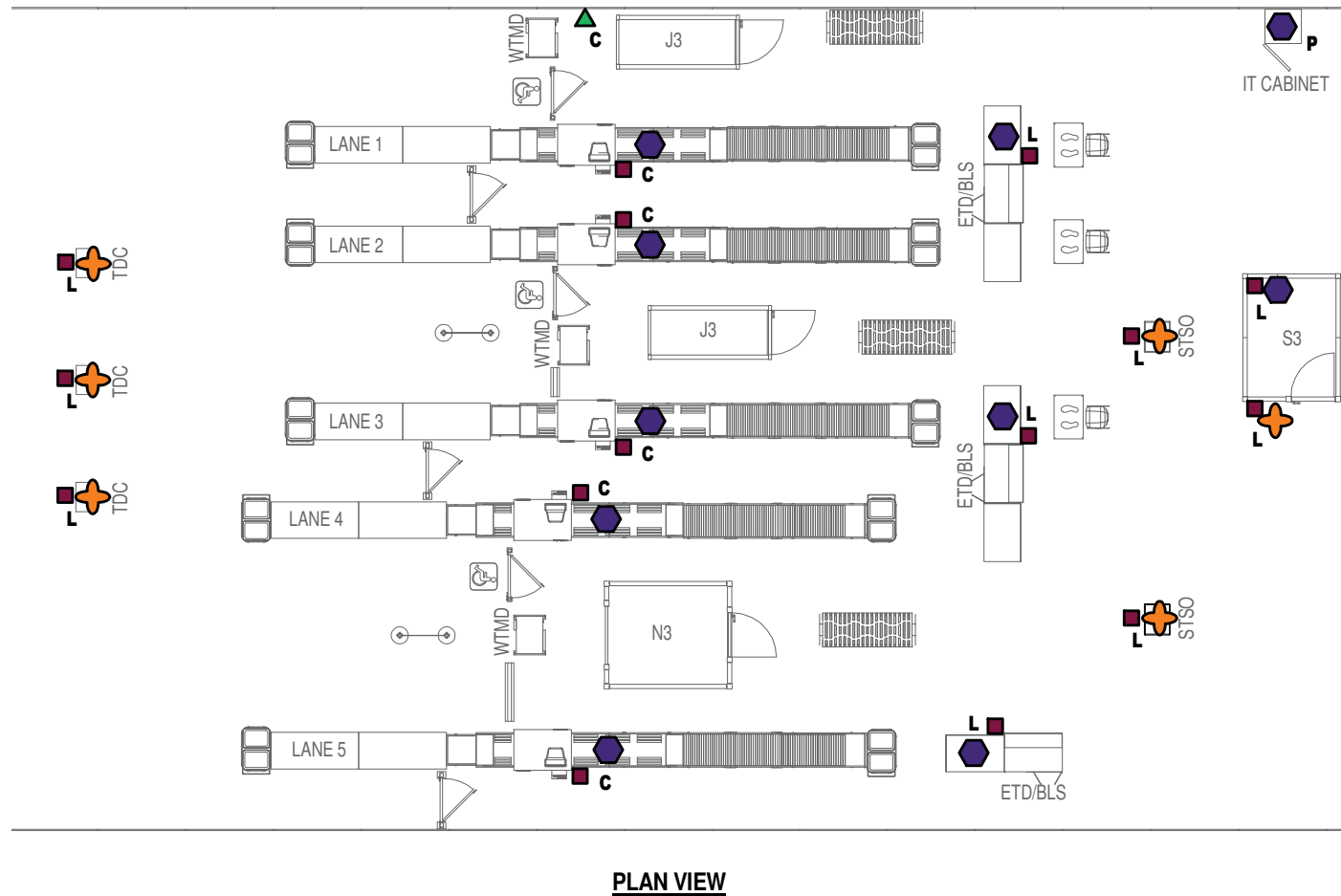

9.5 POWER/DATA PLANS (SEE SECTION 4.5)

Figure 9-10 Arrangement 1 Power/Data Plan



LEGEND

-  RECESSED, FLUSH, OR SURFACE DEVICE
-  TRULY FLUSH RECESSED DEVICE
-  POWER POLE
-  POWER POLE; 36" FLOOR-SUPPORTED POWER POLE WHERE CEILING-SUPPORTED POWER POLE IS NOT FEASIBLE
-  WALL-MOUNTED, RECESSED, FLUSH, SURFACE, OR POWER POLE DEVICE

NOTES

1. LETTER SUBSCRIPT DENOTES CONFIGURATION IN FIGURE 4-6.
2. REFER TO SECTION 2 FOR SPECIFIC ELECTRICAL DEVICE LOCATION.
3. ELECTRICAL DEVICES ARE NOT SHOWN TO SCALE.
4. CHOOSE EITHER FLOOR OR POWER POLE DEVICE DISTRIBUTION.

Figure 9-11 Arrangement 2a Power/Data Plan

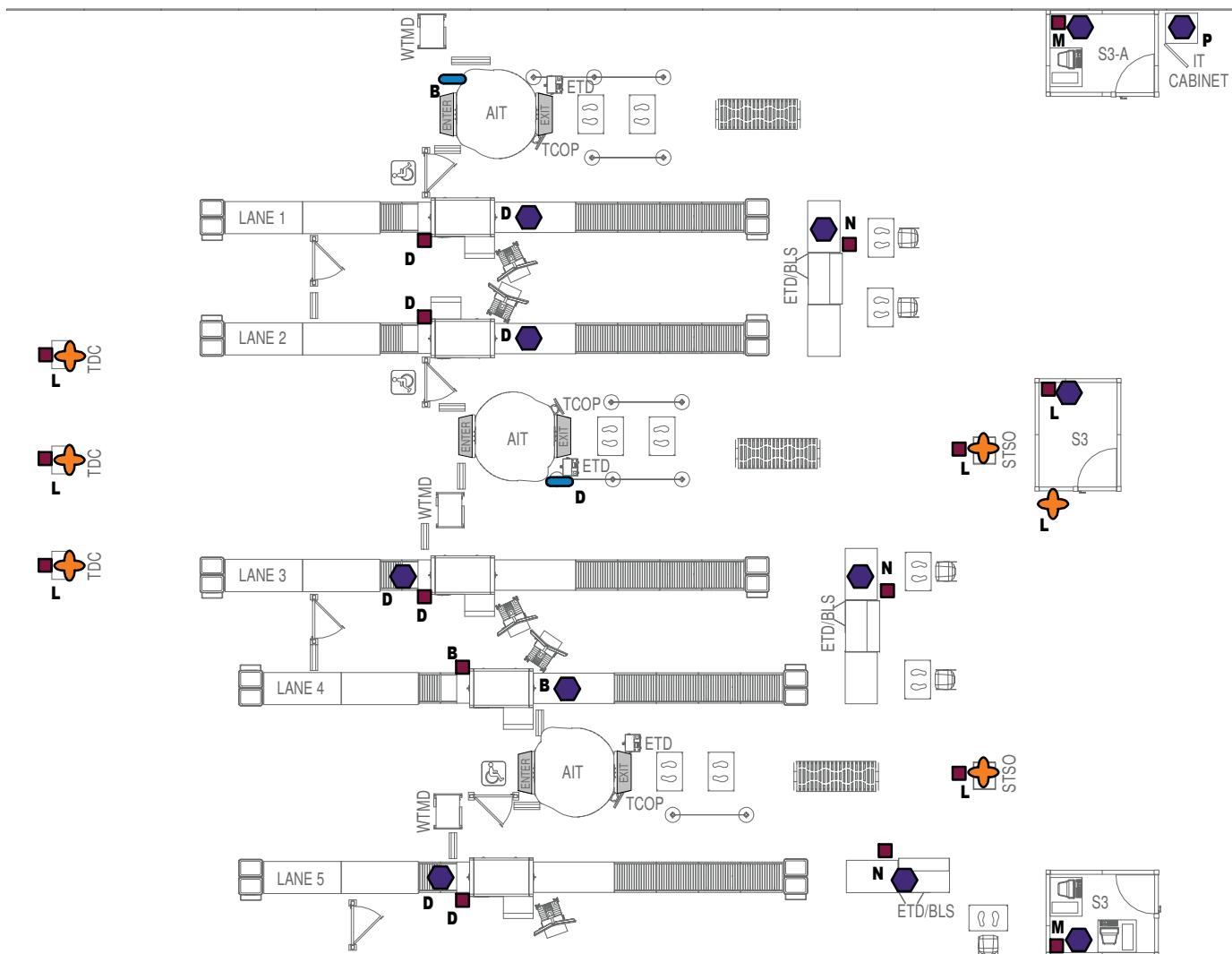

PLAN VIEW

LEGEND

- RECESSED, FLUSH, OR SURFACE DEVICE
- TRULY FLUSH RECESSED DEVICE
- POWER POLE
- POWER POLE; 36" FLOOR-SUPPORTED POWER POLE WHERE CEILING-SUPPORTED POWER POLE IS NOT FEASIBLE
- WALL-MOUNTED, RECESSED, FLUSH, SURFACE, OR POWER POLE DEVICE

NOTES



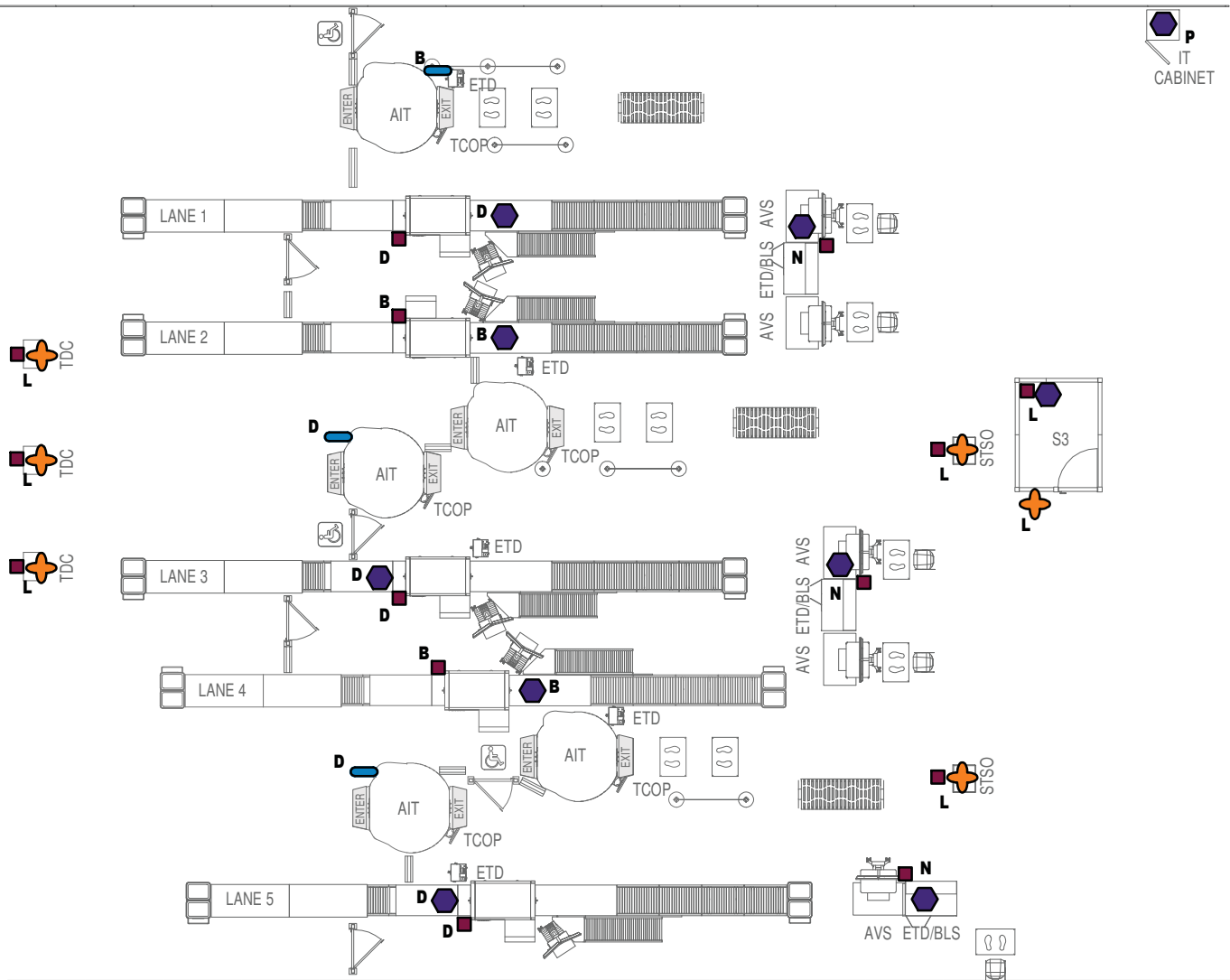

1. LETTER SUBSCRIPT DENOTES CONFIGURATION IN FIGURE 4-6.
2. REFER TO SECTION 2 FOR SPECIFIC ELECTRICAL DEVICE LOCATION.
3. ELECTRICAL DEVICES ARE NOT SHOWN TO SCALE.
4. CHOOSE EITHER FLOOR OR POWER POLE DEVICE DISTRIBUTION.

Figure 9-12 Arrangement 3a Power/Data Plan



PLAN VIEW

LEGEND

-  RECESSED, FLUSH, OR SURFACE DEVICE
- A**
-  TRULY FLUSH RECESSED DEVICE
- A**
-  POWER POLE
- A**
-  POWER POLE; 36" FLOOR-SUPPORTED POWER POLE WHERE CEILING-SUPPORTED POWER POLE IS NOT FEASIBLE
- A**
-  WALL-MOUNTED, RECESSED, FLUSH, SURFACE, OR POWER POLE DEVICE
- A**

NOTES

1. LETTER SUBSCRIPT DENOTES CONFIGURATION IN FIGURE 4-6.
2. REFER TO SECTION 2 FOR SPECIFIC ELECTRICAL DEVICE LOCATION.
3. ELECTRICAL DEVICES ARE NOT SHOWN TO SCALE.
4. CHOOSE EITHER FLOOR OR POWER POLE DEVICE DISTRIBUTION.

Figure 9-13 Arrangement 3b Power/Data Plan

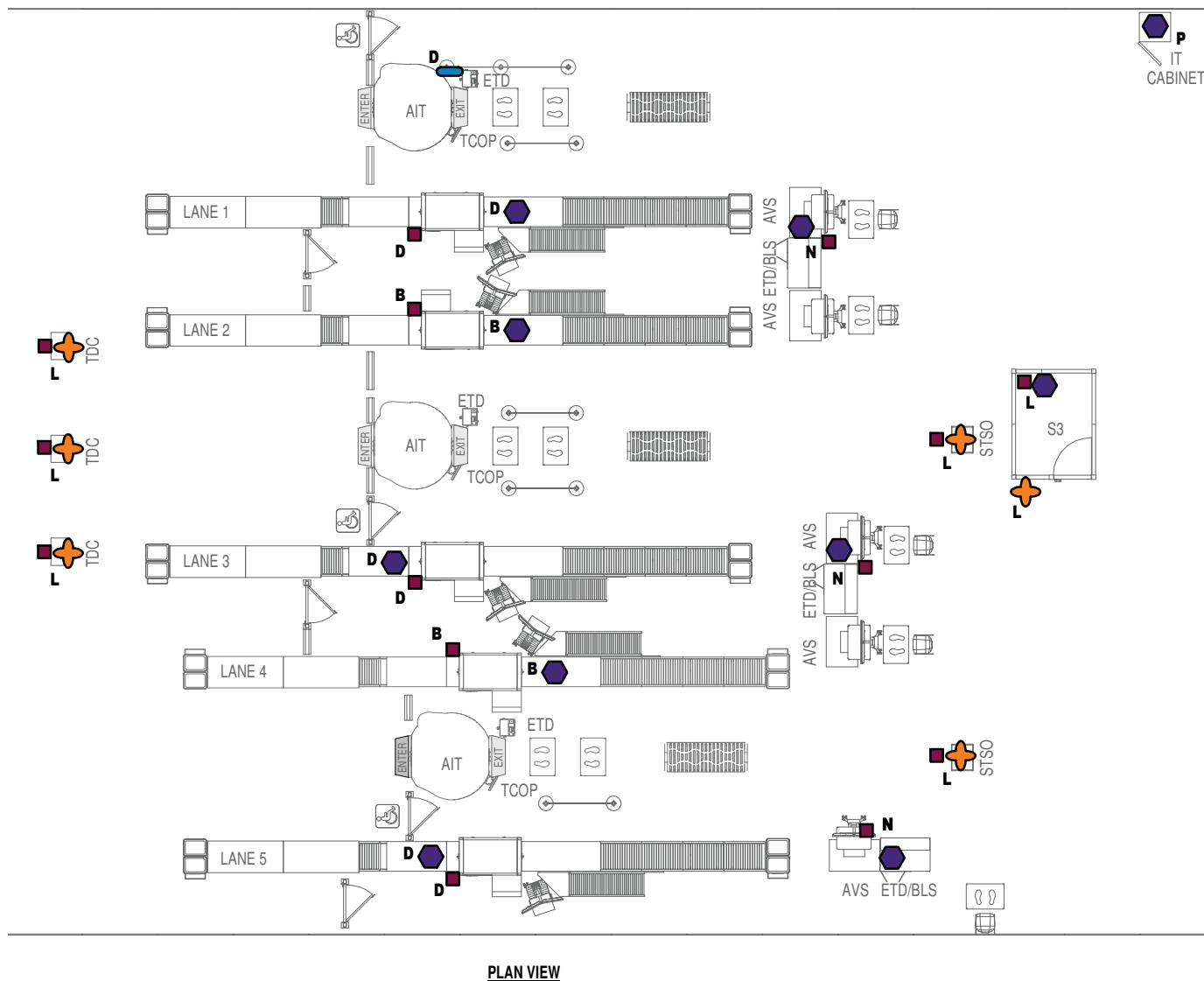

LEGEND

- A** RECESSED, FLUSH, OR SURFACE DEVICE
- A** TRULY FLUSH RECESSED DEVICE
- A** POWER POLE
- A** POWER POLE; 36" FLOOR-SUPPORTED POWER POLE WHERE CEILING-SUPPORTED POWER POLE IS NOT FEASIBLE
- A** WALL-MOUNTED, RECESSED, FLUSH, SURFACE, OR POWER POLE DEVICE

NOTES

1. LETTER SUBSCRIPT DENOTES CONFIGURATION IN FIGURE 4-6.
2. REFER TO SECTION 2 FOR SPECIFIC ELECTRICAL DEVICE LOCATION.
3. ELECTRICAL DEVICES ARE NOT SHOWN TO SCALE.
4. CHOOSE EITHER FLOOR OR POWER POLE DEVICE DISTRIBUTION.

9.6 AUTOMATIC EXPLOSIVE DETECTION SYSTEM (AUTOEDS)

The AutoEDS system, the least common equipment choice for SSCPs, is currently targeted by TSA for Category III/IV airports to replace TRX units at 1-lane checkpoints in order to accomplish both checked and carry-on bag screening with the same unit and security personnel. These units are shown in **Figure 9-14**. Equipment and staffing needs are reduced by combining both TSA functions. TSA screens passengers and their carry-on items first while checked baggage accumulates in a secured area near the divest tables. Once all passengers have been cleared to the hold room, TSA switches the algorithms of the AutoEDS unit to process checked baggage. Cleared checked baggage is then stacked on a cart for the airport or airline representative to transport to the appropriate aircraft.

The AutoEDS units are longer and heavier than TRX or AT units and require a significant amount of square footage and a robust structural floor. Ideally, these units are placed on slab-on-grade foundation or in newer airports with concentrated structural

framing. For proper rigging and installation of the AutoEDS, a 6'-0" wide by 7'-0" high minimum opening will be required along the entire path of delivery. Designers should work with TSA to develop each design.

Since smaller Category III/IV airports have limited checkpoint depth, both manufacturers, Analogic and Reveal, have had to create components that can be combined with their respective unit to create either a short or long version. The short versions for Analogic and Reveal are represented in **Figure 9-15** and **Figure 9-16**, respectively. The long versions for each manufacturer (not shown) have an automatic Bin Return System (BRS) in addition to an extended conveyor length and/or divest and compose length. The Remote Viewing Station (RVS) is a standard component and functions just like the AVS of an AT2 X-ray. It recalls the image of an alarmed bag from the AutoEDS while a TSO performs a target bag search. The preferred location of the RVS is at the end of the lane in the secondary screening area just like the AVS. The RVS for the Reveal unit is also referred to as an Alarm Resolution Workstation/Remote

Figure 9-14 AutoEDS Units

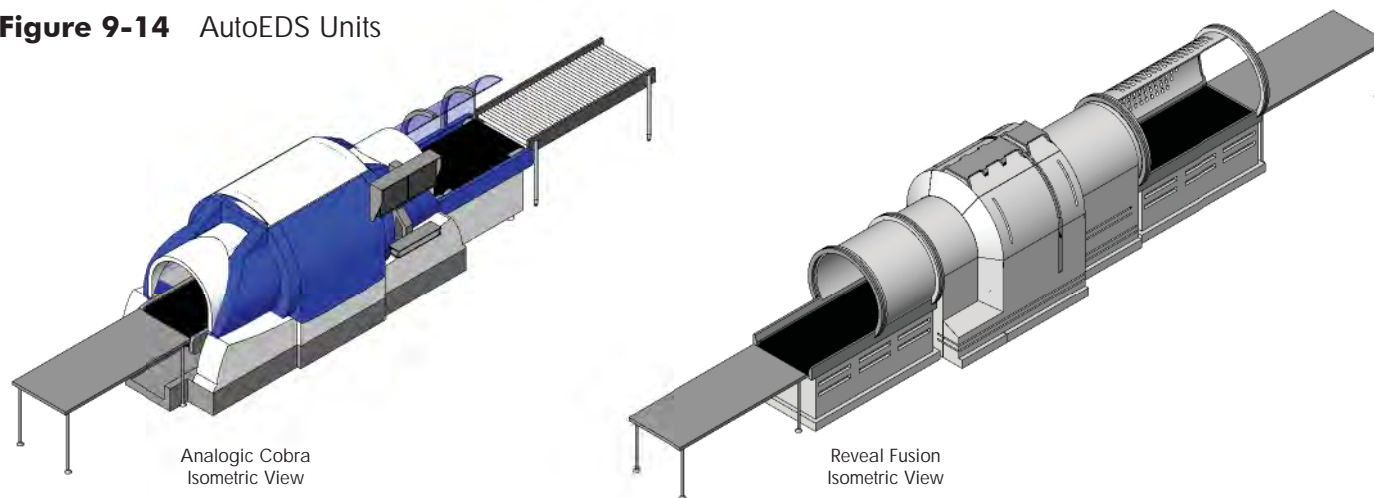

Figure 9-15 AutoEDS - Analogic

Equipment	Quantity	Power Requirements	IT Requirements	Additional Information
Analogic Cobra AutoEDS: short [shown] and long	1 per Cat III/IV checkpoint	<ul style="list-style-type: none"> Dedicated 30A, 208V, 3-Phase, 6.3KVA/unit 4-Pole, 5-Wire Grounding NEMA L21-30R Simplex Receptacle (twistlock) The following components are powered off the AutoEDS. <ul style="list-style-type: none"> » Baggage Viewing Station (BVS) » RVS via vendor-provided power/data cable » Optional automatic BRS 30' power cord from the AutoEDS to the receptacle 	<ul style="list-style-type: none"> Data Drops = 2 Cat5e / Cat6 cable The cable length from the termination point in the IT cabinet to the data outlet in the work area shall not exceed 295'. 30' vendor-provided fiber optic cable from the secure end of the AutoEDS to the RVS. 	<ul style="list-style-type: none"> Weight: <ul style="list-style-type: none"> » 5,800 lbs. » 4' Extended Conveyor: 500 lbs. » 12' Extended Conveyor: 1,450 lbs.

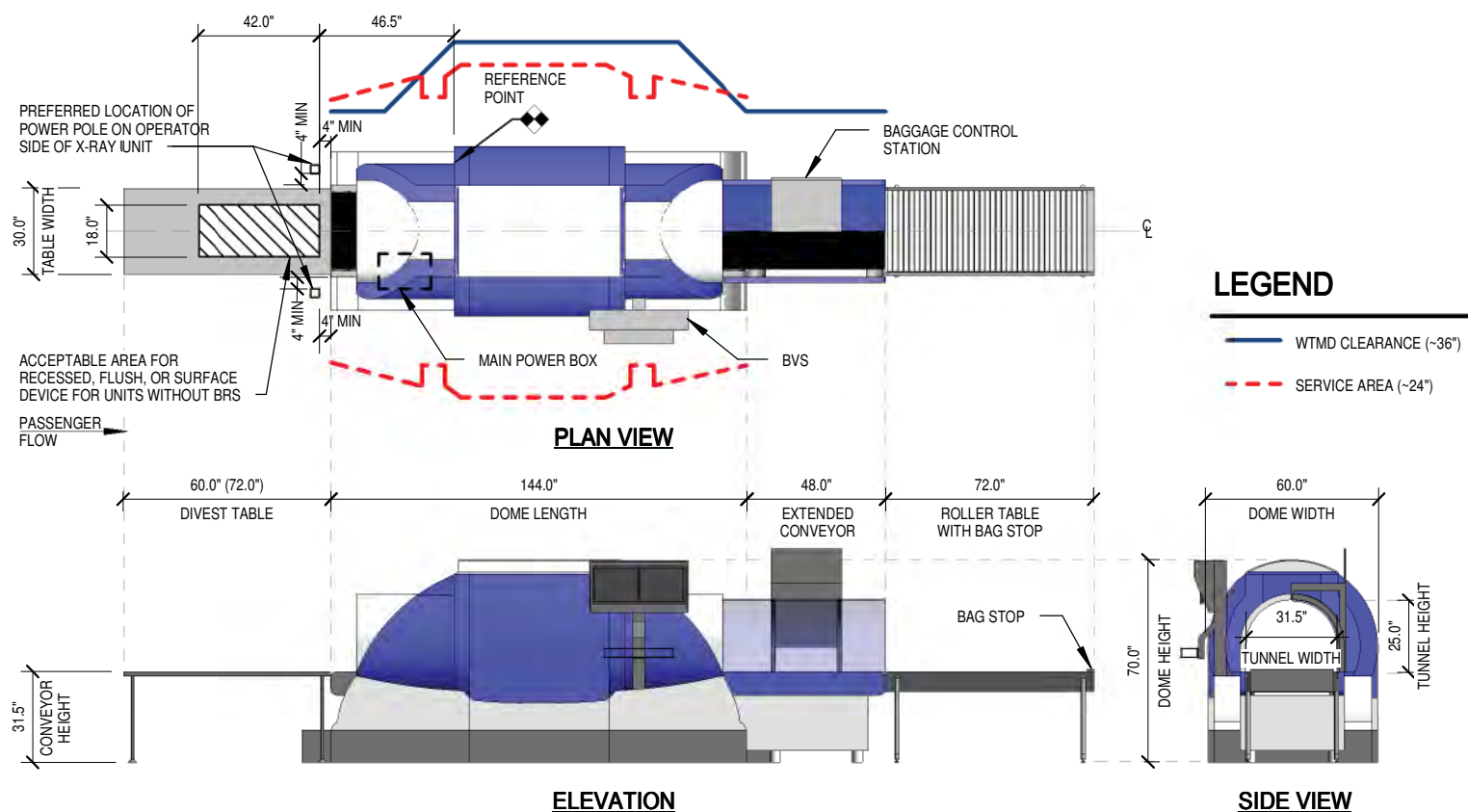
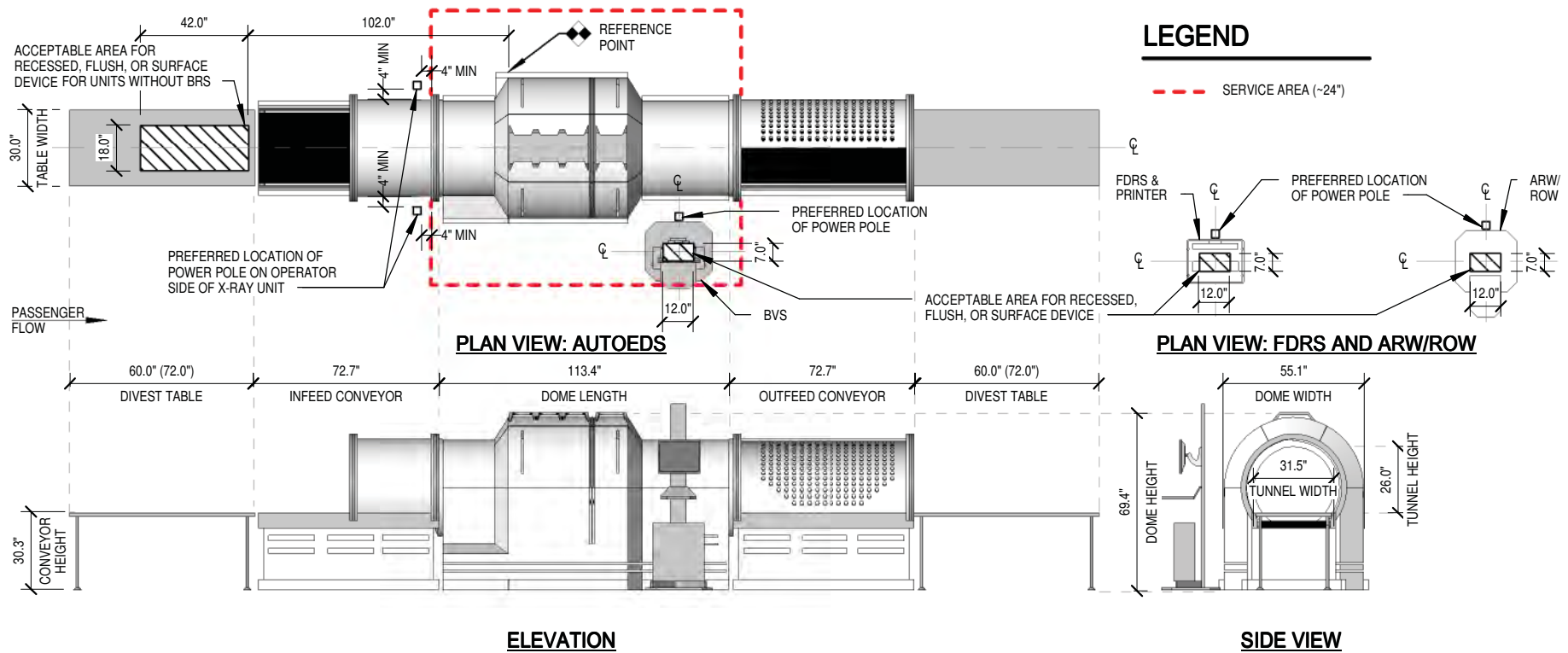

Figure 9-16 AutoEDS - Reveal

Equipment	Quantity	Power Requirements	IT Requirements	Additional Information
Reveal Fusion AutoEDS: short [shown] and long	1 per Cat III/IV checkpoint	<ul style="list-style-type: none"> Dedicated 30A, 220V, Single Phase, 4.2KVA/unit 2-Pole, 3-Wire Grounding NEMA L6-30R Simplex Receptacle (twistlock) 6' power cord from the AutoEDS to the receptacle BVS and FDRS printer requires separate electrical circuit and receptacle from main unit. <ul style="list-style-type: none"> 15A, 120V, 960VA 2-Pole, 3-Wire Grounding NEMA 5-15R Duplex Receptacle 6' power cord from the BVS and FDRS to the receptacle ARW/ROW <ul style="list-style-type: none"> 15A, 120V, 960VA 2-Pole, 3-Wire Grounding NEMA 5-15R Receptacle 6' power cord from the ARW/ROW to the receptacle Optional automatic BRS <ul style="list-style-type: none"> 15A, 120V, 1560VA 2-Pole, 3-Wire Grounding NEMA 5-15R Receptacle 	<ul style="list-style-type: none"> Data Drops = 2 Cat5e / Cat6 cable The cable length from the termination point in the IT cabinet to the data outlet in the work area shall not exceed 295'. Contractor-provided Cat6 cable from the BVS to the FDRS. Contractor-provided Cat6 cable from the FDRS to the ARW/ROW (optional). Contractor-provided fiber optic cable from the AutoEDS to the FDRS. 	<ul style="list-style-type: none"> Weight: <ul style="list-style-type: none"> 5,416 lbs. Infeed/outfeed conveyor: 664 lbs. each Optional BRS: 400 lbs.



9.7 AutoEDS ARRANGEMENTS

The AutoEDS arrangements consist of an AutoEDS, a WTMD, passenger containment, and a secondary screening area that includes an ETD and passenger/carry-on baggage inspection.

The AutoEDS can occur in two different states: a short version for space-confined checkpoints and a long version for open checkpoints. Only the short version is shown in this guide. Each manufacturer has created components that can be added or removed based on the space available and the functions required. The long versions of this unit contain an automatic Bin Return System (BRS) which is helpful to both the passenger and the TSOs but it is very difficult to deploy because of the amount of checkpoint depth required.

The AutoEDS is currently being deployed as a carry-on bag screening only device, but it is anticipated that this will change to a “dual-use” mode that will screen carry-on and checked bags. The following items should be considered for dual-use deployment.

- The checkpoint area must have a minimum of 16’-6” width by 51’-11” depth to accommodate the shortest version of both AutoEDS manufacturers.
- Designs will be unique to each airport and may necessitate changes to the designs included in this guide. Any changes must be vetted by the appropriate personnel within TSA HQ.
- Airports considered will have no more than one checkpoint lane and will not have a maximum passenger throughput greater than 60 passengers per hour.
- Passenger screening will occur on the WTMD side of the AutoEDS; checked baggage screening will occur on the TSO side of the AutoEDS.
- The AutoEDS location must be evaluated to facilitate the secure, safe, and efficient staging and movement of cleared checked baggage from the checkpoint by the appropriate airline representatives.

- Unless the airport provides a power belt or rollers to convey screened checked baggage to the airlines, a cart will be provided by TSA to stage cleared checked baggage. Airport or airline representatives are responsible for transporting cleared checked baggage.
- Checked baggage will be screened by the AutoEDS as well as passenger carry-on items.
- Current stand-alone checked baggage areas in the lobby or designated bag rooms will be replaced by the dual-use AutoEDS.

The following pages represent the short versions of both manufacturers in 2-D and 3-D. **Figure 9-5** and **Figure 9-6** represent the isometric views of an optimized 1-to-1 layout. **Figure 9-7** represents the plan views of the same layout with the recommended spacing shown. These dimensions are guidelines to use when laying out an AutoEDS checkpoint. Adjustments to these dimensions may need to be made due to site conditions. This is acceptable as long as the spacing is within the desired range. Deviations from the minimum and maximum spacing must receive OSC approval before implementation. Every attempt to achieve the dimensions listed in the table should be made when designing a checkpoint with AutoEDS equipment. The spacing requirements are the same regardless of the make and model of the AutoEDS.

Figure 9-17 Analogic Cobra
Isometric View

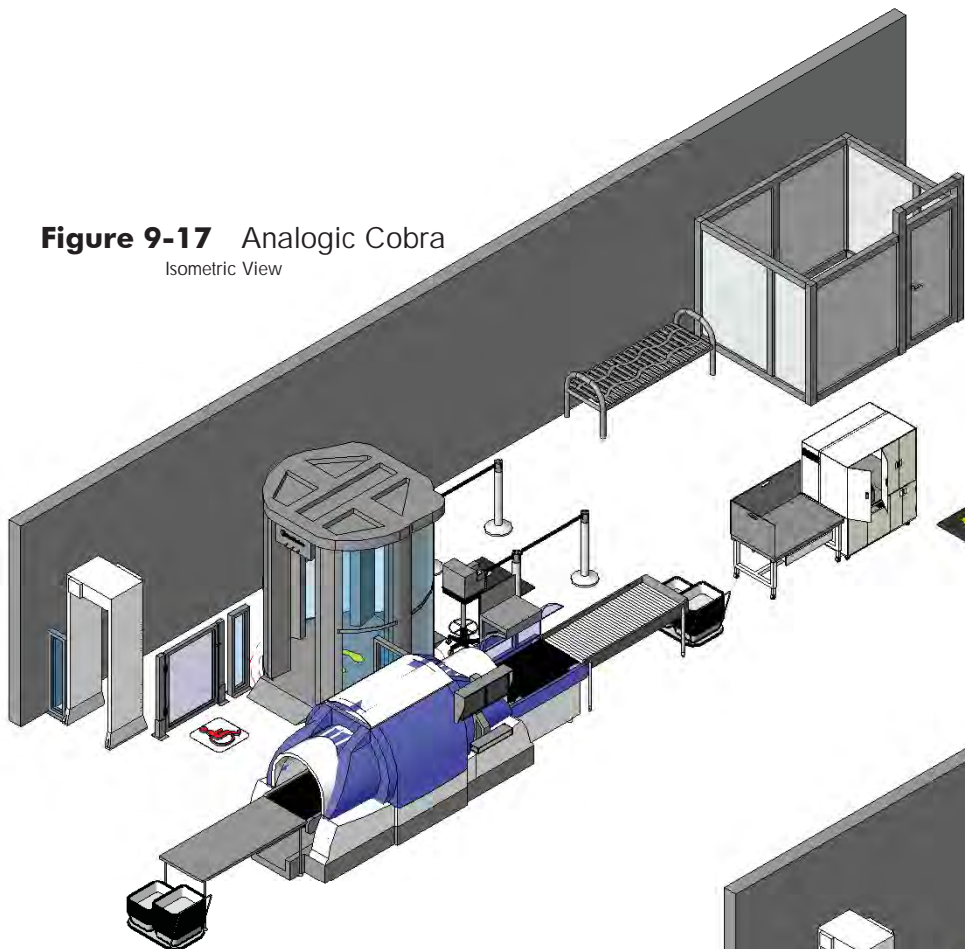

Figure 9-18 Reveal Fusion
Isometric View

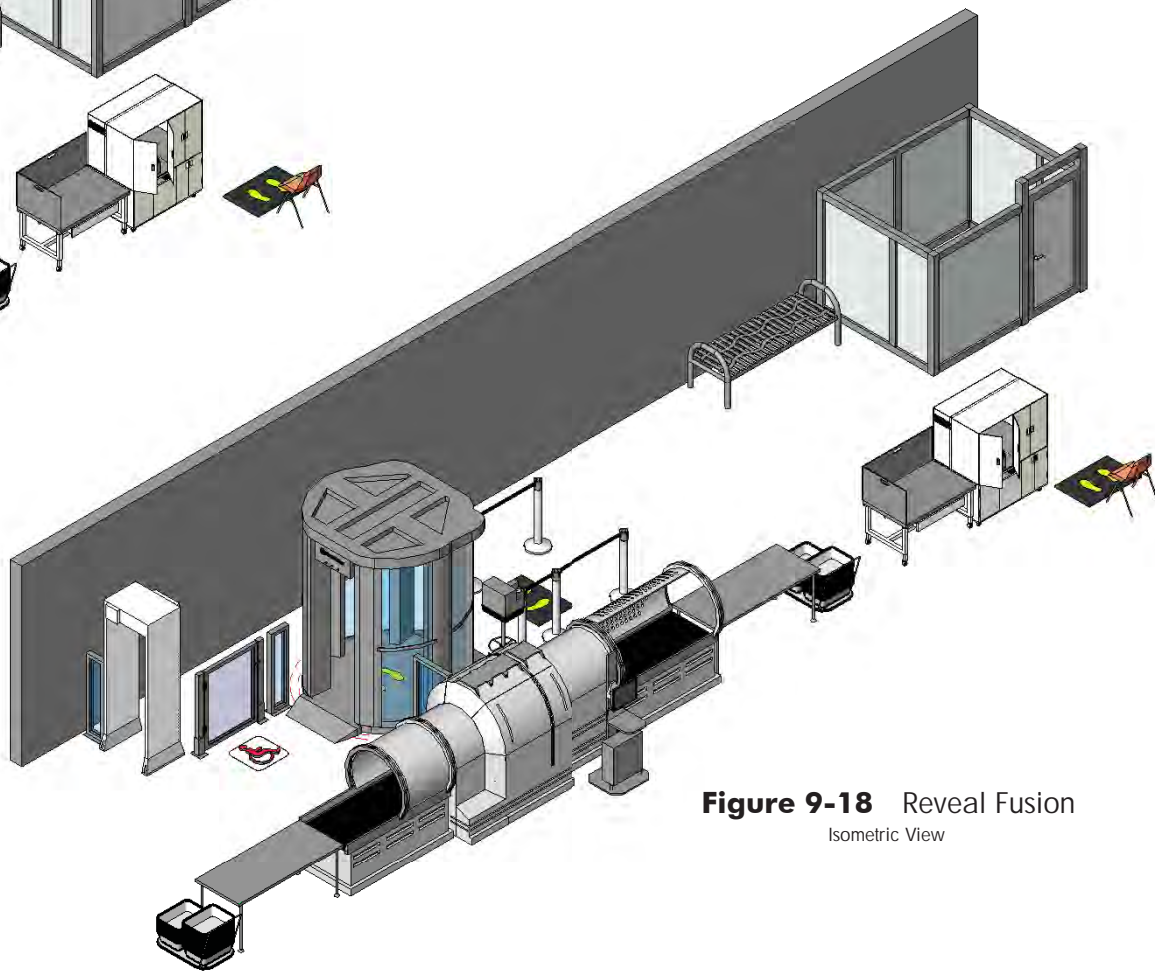
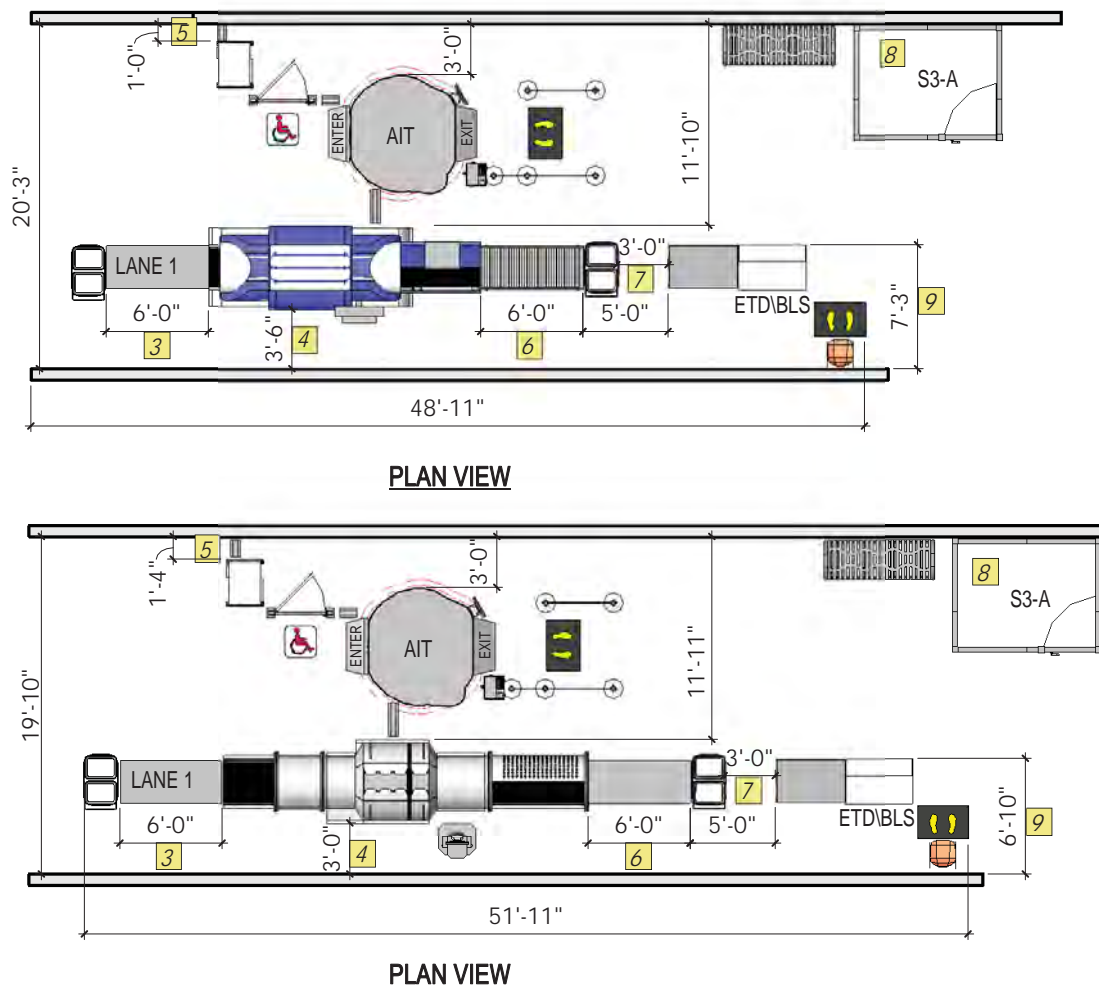

Figure 9-19 Analogic Cobra Recommended Spacing



LEGEND

- 1 3'-0" minimum queue lane width (*not shown*)
- 2 4'-0" - 15'-0" from the TDC podium operator side to nearest bin cart (*not shown*)
- 3 6'-0" minimum of divest tables
- 4 3'-0" minimum from AutoEDS dome to wall
- 5 12" maximum between ancillary or screening equipment separating the non-sterile area from the sterile area (*not every location shown*)
- 6 6'-0" minimum of composure rollers/tables
- 7 3'-0" minimum from bin cart to the secondary screening area to allow for TSO bypass or 5'-0" minimum from last composure roller to secondary screening area to allow for TSO bypass
- 8 6' x 8' Private Screening Room (*not shown*)
- 9 6'-0" x 6'-0" minimum for passenger inspection at secondary screening area